

# 5A and 2.5A High Efficiency Switching Regulators

## FEATURES

- Wide Input Voltage Range: 3V to 60V
- Low Quiescent Current: 6mA
- Internal 5A Switch (2.5A for LT1071)
- Very Few External Parts Required
- Self Protected Against Overloads
- Operates in Nearly All Switching Topologies
- Shutdown Mode Draws Only 50 $\mu$ A Supply Current
- Flyback Regulated Mode Has Fully Floating Outputs
- Comes in Standard 5-Pin TO-220 Package
- Can be Externally Synchronized (Consult Factory)

## APPLICATIONS

- Logic Supply 5V at 10A
- 5V Logic to  $\pm$ 15V Op Amp Supply
- Off-Line Converter Up to 200W
- Battery Upconverter
- Power Inverter (+ to -) or (- to +)
- Fully Floating Multiple Outputs
- For Lower Current Applications, See the LT1072

### USER NOTE:

This data sheet is only intended to provide specifications, graphs and a general functional description of the LT1070/LT1071. Application circuits are included to show the capability of the LT1070/LT1071. A complete design manual (AN19) should be obtained to assist in developing new designs. This manual contains a comprehensive discussion of both the LT1070 and the external components used with it, as well as complete formulas for calculating the values of these components. The manual can also be used for the LT1071 by factoring in the lower switch current rating. A second Application Note, AN25, which details off-line applications is available.

## DESCRIPTION

The LT<sup>®</sup>1070/LT1071 are monolithic high power switching regulators. They can be operated in all standard switching configurations including buck, boost, flyback, forward, inverting and "Cuk". A high current, high efficiency switch is included on the die along with all oscillator, control and protection circuitry. Integration of all functions allows the LT1070/LT1071 to be built in a standard 5-pin TO-220 power package. This makes it extremely easy to use and provides "bust proof" operation similar to that obtained with 3-pin linear regulators.

The LT1070/LT1071 operate with supply voltages from 3V to 60V, and draw only 6mA quiescent current. They can deliver load power up to 100W with no external power devices. By utilizing current mode switching techniques, they provide excellent AC and DC load and line regulation.

The LT1070/LT1071 have many unique features not found even on the vastly more difficult to use low power control chips presently available. They use adaptive antisat switch drive to allow very wide ranging load currents with no loss in efficiency. An externally activated shutdown mode reduces total supply current to 50 $\mu$ A typical for standby operation. Totally isolated and regulated outputs can be generated by using the optional "flyback regulation mode" built into the LT1070/LT1071, without the need for optocouplers or extra transformer windings.

LT, LTC and LT are registered trademarks of Linear Technology Corporation.

## TYPICAL APPLICATION

Boost Converter (5V to 12V)

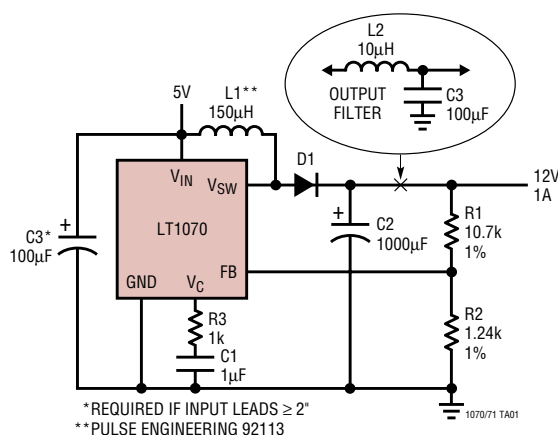

Maximum Output Power\*

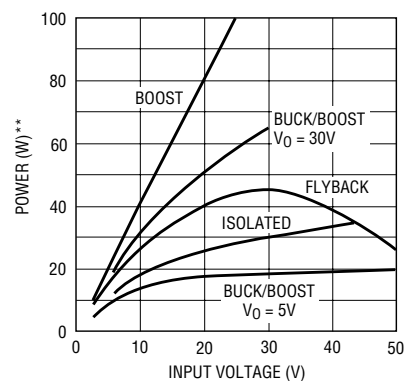

1070/71 TA02  
 \*ROUGH GUIDE ONLY. BUCK MODE  $P_{OUT} = 5A \cdot V_{OUT}$ .  
 SPECIAL TOPOLOGIES DELIVER MORE POWER  
 \*\*DIVIDE VERTICAL POWER SCALE BY 2 FOR LT1071

# LT1070/LT1071

## ABSOLUTE MAXIMUM RATINGS (Note 1)

Supply Voltage	LT1070/LT1071 (Note 2) ..... 40V	Operating Junction Temperature Range	Commercial (Operating) ..... 0°C to 100°C
	LT1070HV/LT1071HV (Note 2) ..... 60V		Commercial (Short Circuit) ..... 0°C to 125°C
Switch Output Voltage	LT1070/LT1071 ..... 65V		Industrial ..... -40°C to 125°C
	LT1070HV/LT1071HV ..... 75V		Military ( <b>OBSOLETE</b> ) ..... -55°C to 150°C
Feedback Pin Voltage (Transient, 1ms) ..... ±15V		Storage Temperature Range ..... -65°C to 150°C	Lead Temperature (Soldering, 10 sec) ..... 300°C

## PACKAGE/ORDER INFORMATION

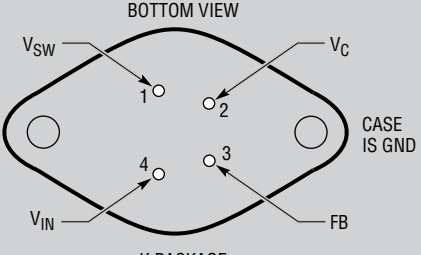
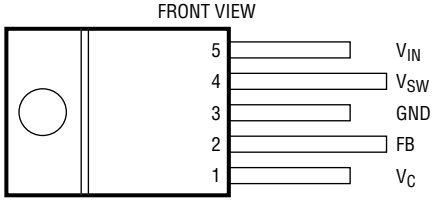
 <p><b>BOTTOM VIEW</b></p> <p><b>K PACKAGE</b> 4-LEAD TO-3 METAL CAN</p> <p><math>T_{JMAX} = 100^{\circ}\text{C}</math>, <math>\theta_{JA} = 35^{\circ}\text{C/W}</math>, <math>Q_{JC} = 2^{\circ}\text{C}</math> (LT1070C, I)  <math>T_{JMAX} = 150^{\circ}\text{C}</math>, <math>\theta_{JA} = 35^{\circ}\text{C/W}</math>, <math>Q_{JC} = 2^{\circ}\text{C}</math> (LT1070M)  <math>T_{JMAX} = 100^{\circ}\text{C}</math>, <math>\theta_{JA} = 35^{\circ}\text{C/W}</math>, <math>Q_{JC} = 4^{\circ}\text{C}</math> (LT1071C, I)  <math>T_{JMAX} = 150^{\circ}\text{C}</math>, <math>\theta_{JA} = 35^{\circ}\text{C/W}</math>, <math>Q_{JC} = 4^{\circ}\text{C}</math> (LT1071M)</p> <p><b>OBSOLETE PACKAGE</b> Consider the T5 Package for Alternate Source</p>	ORDER PART NUMBER	 <p><b>FRONT VIEW</b></p> <p><b>T PACKAGE</b> 5-LEAD PLASTIC TO-220</p> <p><math>T_{JMAX} = 100^{\circ}\text{C}</math>, <math>\theta_{JA} = 75^{\circ}\text{C/W}</math>, <math>Q_{JC} = 2^{\circ}\text{C}</math> (LT1070C, I)  <math>T_{JMAX} = 100^{\circ}\text{C}</math>, <math>\theta_{JA} = 75^{\circ}\text{C/W}</math>, <math>Q_{JC} = 4^{\circ}\text{C}</math> (LT1071C)</p>	ORDER PART NUMBER
	LT1070CK LT1070HVCK LT1070HVMK LT1070IK LT1070MK LT1071CK LT1071HVCK LT1071HVMK LT1071MK		LT1070CT LT1070HVCT LT1070HVIT LT1070IT LT1071CT LT1071HVCT LT1071HVIT LT1071IT

Consult LTC Marketing for parts specified with wider operating temperature ranges.

## ELECTRICAL CHARACTERISTICS

The ● denotes the specifications which apply over the full operating temperature range, otherwise specifications are at  $T_A = 25^{\circ}\text{C}$ .  $V_{IN} = 15\text{V}$ ,  $V_C = 0.5\text{V}$ ,  $V_{FB} = V_{REF}$ , output pin open unless otherwise specified.

SYMBOL	PARAMETER	CONDITIONS	MIN	TYP	MAX	UNITS
$V_{REF}$	Reference Voltage	Measured at Feedback Pin, $V_C = 0.8\text{V}$	● 1.224	1.244	1.264	V
			1.214	1.244	1.274	V
$I_B$	Feedback Input Current	$V_{FB} = V_{REF}$	●	350	750	nA
			●		1100	nA
$g_m$	Error Amplifier Transconductance	$\Delta I_C = \pm 25\mu\text{A}$	● 3000	4400	6000	$\mu\text{mho}$
			● 2400		7000	$\mu\text{mho}$
	Error Amplifier Source or Sink Current	$V_C = 1.5\text{V}$	● 150	200	350	$\mu\text{A}$
			● 120		400	$\mu\text{A}$
	Error Amplifier Clamp Voltage	Hi Clamp, $V_{FB} = 1\text{V}$ Lo Clamp, $V_{FB} = 1.5\text{V}$	● 1.80		2.30	V
			0.25	0.38	0.52	V
	Reference Voltage Line Regulation	$3\text{V} \leq V_{IN} \leq V_{MAX}$ , $V_C = 0.8\text{V}$	●		0.03	%/V
$A_V$	Error Amplifier Voltage Gain	$0.9\text{V} \leq V_C \leq 1.4\text{V}$	● 500	800		V/V
			●	2.6	3.0	V
$I_Q$	Supply Current	$3\text{V} \leq V_{IN} \leq V_{MAX}$ , $V_C = 0.6\text{V}$	●	6	9	mA
			●	0.8	0.9	1.08
	Control Pin Threshold	Duty Cycle = 0	● 0.6		1.25	V
			●	0.4	0.45	0.54
	Normal/Flyback Threshold on Feedback Pin		●			V

10701fe

**ELECTRICAL CHARACTERISTICS** The ● denotes the specifications which apply over the full operating temperature range, otherwise specifications are at T<sub>A</sub> = 25°C. V<sub>IN</sub> = 15V, V<sub>C</sub> = 0.5V, V<sub>FB</sub> = V<sub>REF</sub>, output pin open unless otherwise specified.

SYMBOL	PARAMETER	CONDITIONS	MIN	TYP	MAX	UNITS
V <sub>FB</sub>	Flyback Reference Voltage	I <sub>FB</sub> = 50μA	15	16.3	17.6	V
			● 14		18.0	V
	Change in Flyback Reference Voltage	0.05 ≤ I <sub>FB</sub> ≤ 1mA	4.5	6.8	8.5	V
	Flyback Reference Voltage Line Regulation	I <sub>FB</sub> = 50μA, 3V ≤ V <sub>IN</sub> ≤ V <sub>MAX</sub> (Note 3)		0.01	0.03	%/V
	Flyback Amplifier Transconductance (g <sub>m</sub> )	ΔI <sub>C</sub> = ±10μA	150	300	650	μmho
	Flyback Amplifier Source and Sink Current	V <sub>C</sub> = 0.6V, I <sub>FB</sub> = 50μA (Source) V <sub>C</sub> = 0.6V, I <sub>FB</sub> = 50μA (Sink)	● 15	32	70	μA
			● 25	40	70	μA
B <sub>V</sub>	Output Switch Breakdown Voltage	3V ≤ V <sub>IN</sub> ≤ V <sub>MAX</sub> , I <sub>SW</sub> = 1.5mA (LT1070/LT1071) (LT1070HV/LT1071HV)	● 65	90		V
			● 75	90		V
V <sub>SAT</sub>	Output Switch “On” Resistance (Note 4)	LT1070	●	0.15	0.24	Ω
		LT1071	●	0.30	0.50	Ω
	Control Voltage to Switch Current Transconductance	LT1070		8		A/V
		LT1071		4		A/V
I <sub>LIM</sub>	Switch Current Limit (LT1070)	Duty Cycle ≤ 50%, T <sub>J</sub> ≥ 25°C	● 5		10	A
		Duty Cycle ≤ 50%, T <sub>J</sub> < 25°C	● 5		11	A
		Duty Cycle = 80% (Note 5)	● 4		10	A
	Switch Current Limit (LT1071)	Duty Cycle ≤ 50%, T <sub>J</sub> ≥ 25°C	● 2.5		5.0	A
		Duty Cycle ≤ 50%, T <sub>J</sub> < 25°C	● 2.5		5.5	A
		Duty Cycle = 80% (Note 5)	● 2.0		5.0	A
$\frac{\Delta I_{IN}}{\Delta I_{SW}}$	Supply Current Increase During Switch “On” Time			25	35	mA/A
f	Switching Frequency		● 35	40	45	kHz
DC (Max)	Maximum Switch Duty Cycle		90	92	97	%
	Flyback Sense Delay Time			1.5		μs
	Shutdown Mode Supply Current	3V ≤ V <sub>IN</sub> ≤ V <sub>MAX</sub> , V <sub>C</sub> = 0.05V		100	250	μA
	Shutdown Mode Threshold Voltage	3V ≤ V <sub>IN</sub> ≤ V <sub>MAX</sub>	100	150	250	mV
			● 50		300	mV

**Note 1:** Absolute Maximum Ratings are those values beyond which the life of a device may be impaired.

**Note 2:** Minimum switch “on” time for the LT1070/LT1071 in current limit is ≈ 1μs. This limits the maximum input voltage during short-circuit conditions, in the buck and inverting modes only, to ≈ 35V. Normal (unshorted) conditions are not affected. Mask changes are being implemented which will reduce minimum “on” time to ≤ 1μs, increasing maximum short-circuit input voltage above 40V. If the present LT1070/LT1071 (contact factory for package date code) is being operated in the buck or inverting mode at high input voltages and short-circuit conditions are expected, a resistor must be placed in series with the inductor, as follows:

The value of the resistor is given by:

$$R = \frac{t \cdot f \cdot V_{IN} - V_F}{I_{LIMIT}} - R_L$$

t = Minimum “on” time of LT1070/LT1071 in current limit, ≈ 1μs

f = Operating frequency (40kHz)

V<sub>F</sub> = Forward voltage of external catch diode at I<sub>LIMIT</sub>

I<sub>LIMIT</sub> = Current limit of LT1070 (≈ 8A), LT1071 (≈ 4A)

R<sub>L</sub> = Internal series resistance of inductor

**Note 3:** V<sub>MAX</sub> = 55V for LT1070HV and LT1071HV to avoid switch breakdown.

**Note 4:** Measured with V<sub>C</sub> in hi clamp, V<sub>FB</sub> = 0.8V. I<sub>SW</sub> = 4A for LT1070 and 2A for LT1071.

**Note 5:** For duty cycles (DC) between 50% and 80%, minimum guaranteed switch current is given by I<sub>LIM</sub> = 3.33 (2 – DC) for the LT1070 and I<sub>LIM</sub> = 1.67 (2 – DC) for the LT1071.

## TYPICAL PERFORMANCE CHARACTERISTICS

**Switch Current Limit vs Duty Cycle**

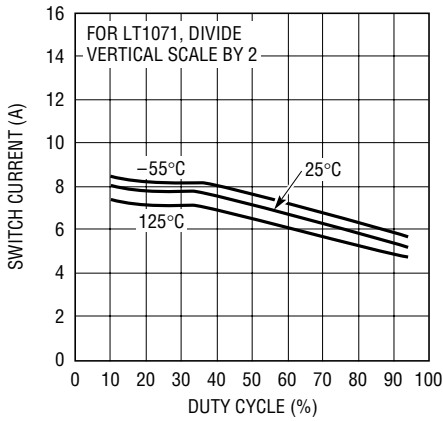

1070/71 G01

**Maximum Duty Cycle**

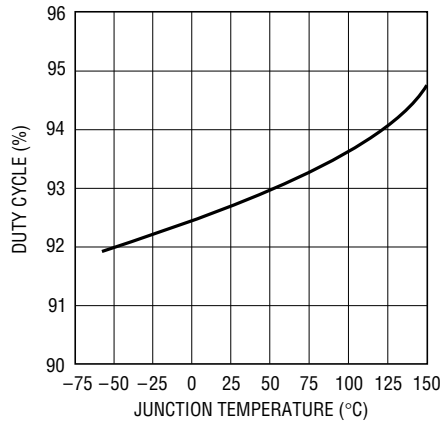

1070/71 G02

**Flyback Blanking Time**

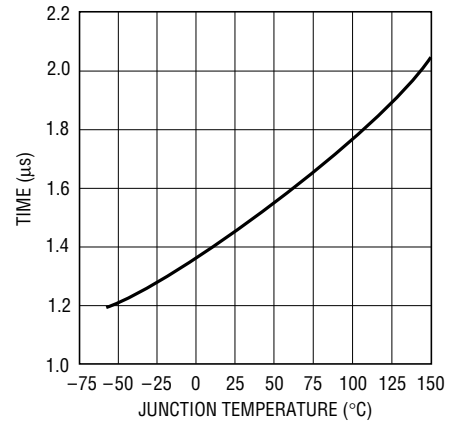

1070/71 G03

**Minimum Input Voltage**

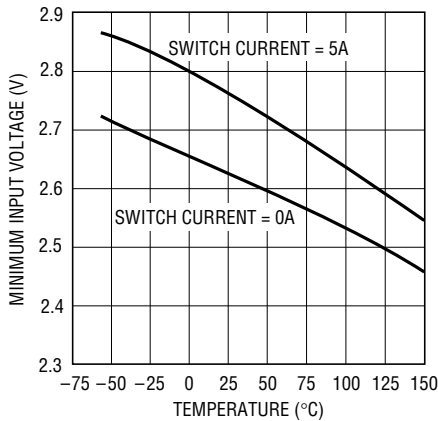

1070/71 G04

**Switch Saturation Voltage**

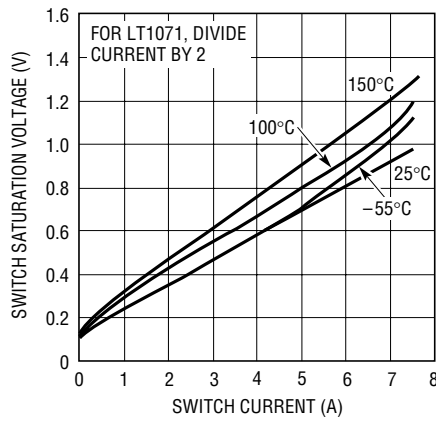

1070/71 G05

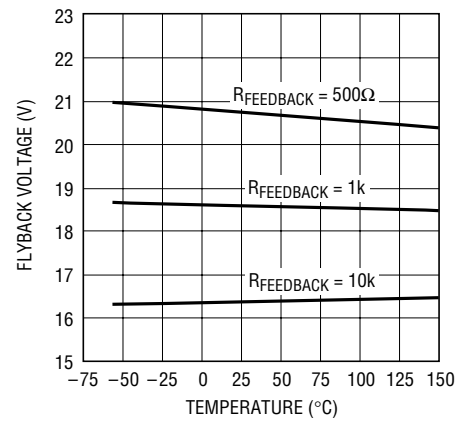

1070/71 G06

**Line Regulation**

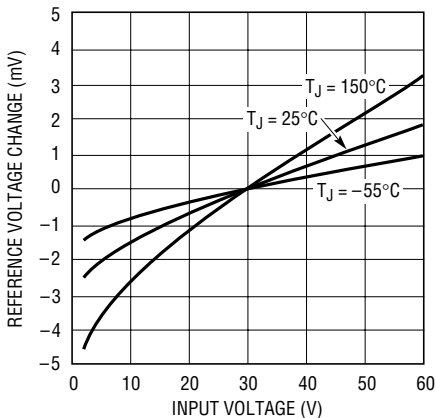

1070/71 G07

**Reference Voltage vs Temperature**

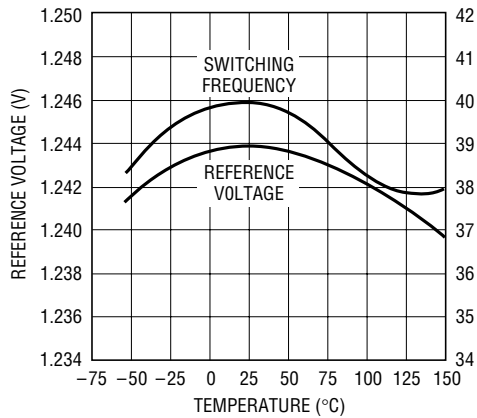

1070/71 G08

**Feedback Bias Current vs Temperature**

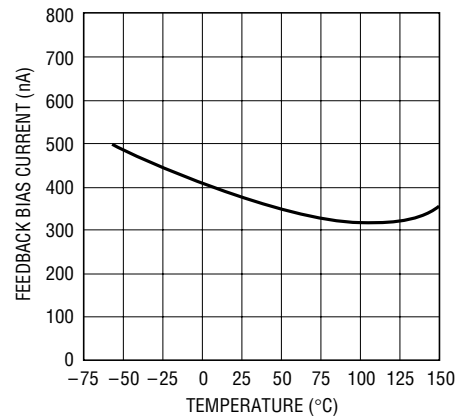

1070/71 G09

# TYPICAL PERFORMANCE CHARACTERISTICS

**Driver Current\* vs Switch Current**

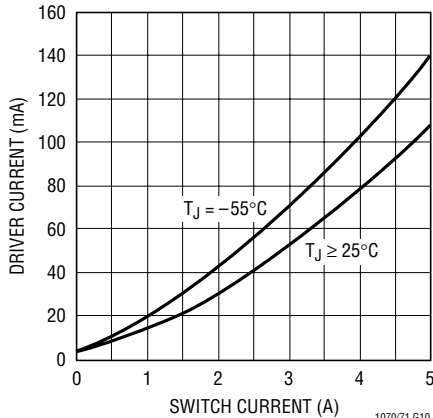

\* AVERAGE LT1070 POWER SUPPLY CURRENT IS FOUND BY MULTIPLYING DRIVER CURRENT BY DUTY CYCLE, THEN ADDING QUIESCENT CURRENT

**Supply Current vs Input Voltage\***

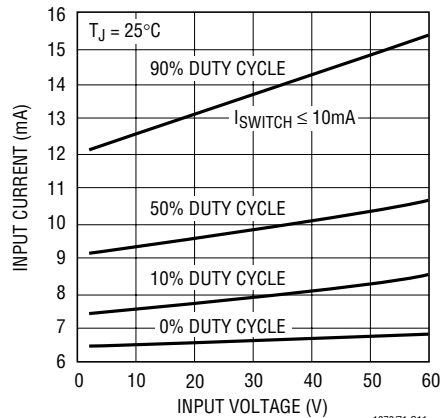

\* UNDER VERY LOW OUTPUT CURRENT CONDITIONS, DUTY CYCLE FOR MOST CIRCUITS WILL APPROACH 10% OR LESS

**Supply Current vs Supply Voltage (Shutdown Mode)**

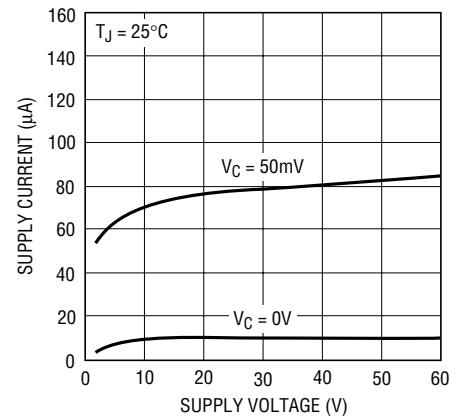

1070/71 G12

**Normal/Flyback Mode Threshold on Feedback Pin**

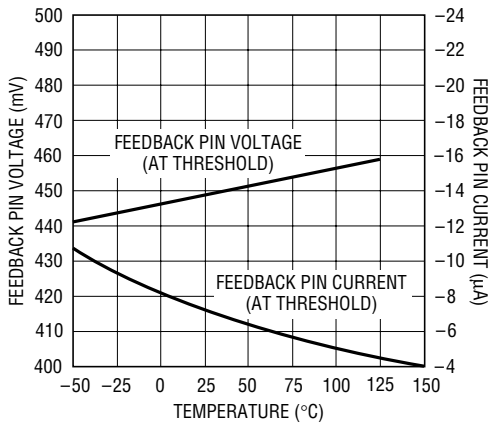

1070/71 G13

**Shutdown Mode Supply Current**

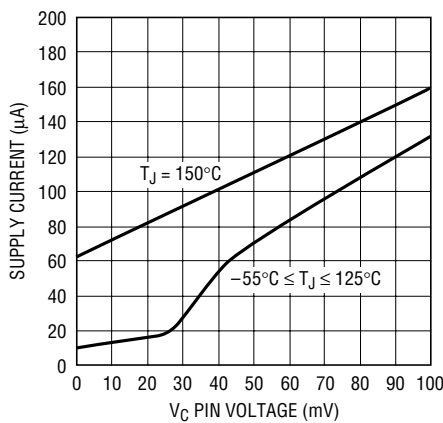

1070/71 G14

**Error Amplifier Transconductance**

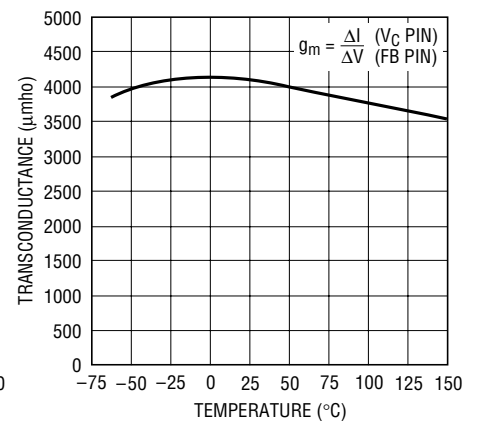

1070/71 G14

**Shutdown Thresholds**

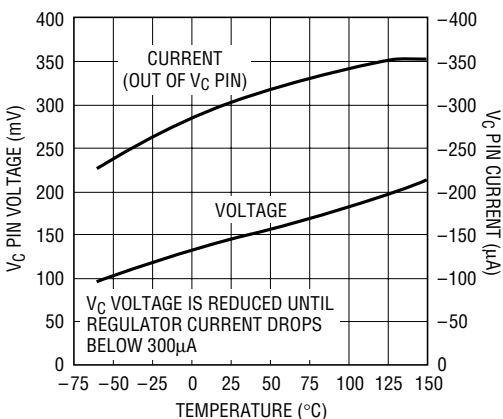

1070/71 G16

**Idle Supply Current vs Temperature**

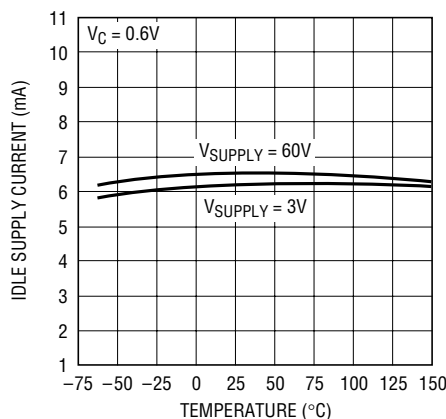

1070/71 G14

**Feedback Pin Clamp Voltage**

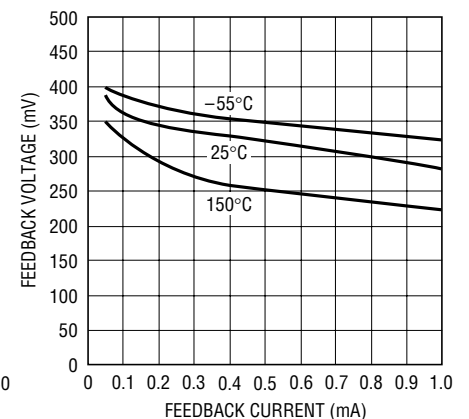

1070/71 G18  
10701fe

## TYPICAL PERFORMANCE CHARACTERISTICS

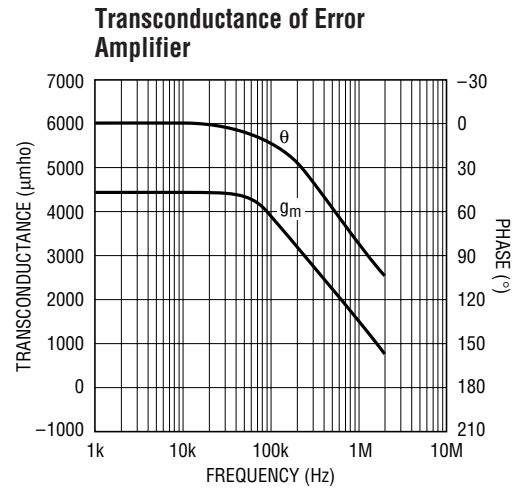
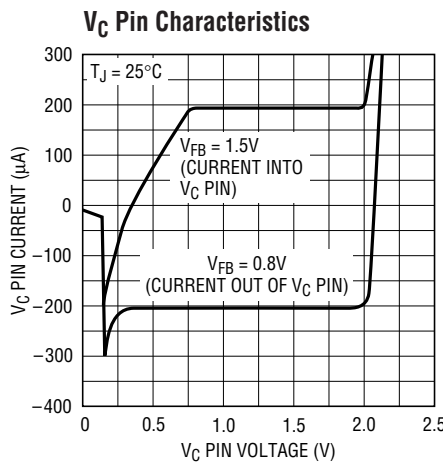
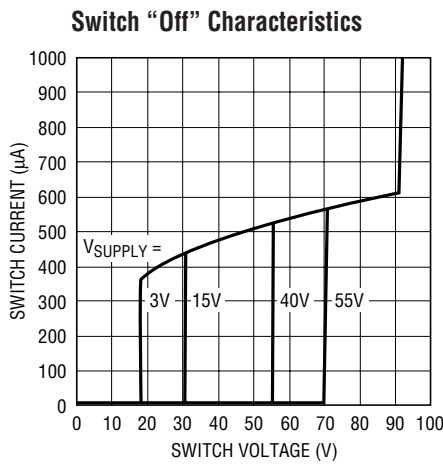

## BLOCK DIAGRAM

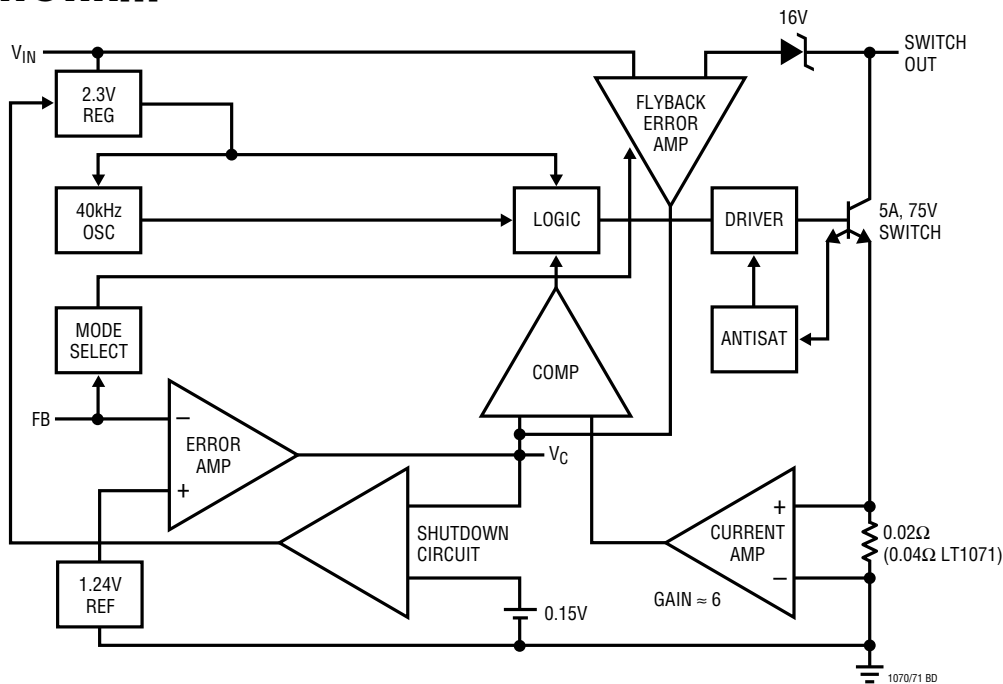

## OPERATION

The LT1070/LT1071 is a current mode switcher. This means that switch duty cycle is directly controlled by switch current rather than by output voltage. Referring to the Block Diagram, the switch is turned “on” at the start of each oscillator cycle. It is turned “off” when switch current reaches a predetermined level. Control of output

voltage is obtained by using the output of a voltage sensing error amplifier to set current trip level. This technique has several advantages. First, it has immediate response to input voltage variations, unlike ordinary switchers which have notoriously poor line transient response. Second, it reduces the 90° phase shift at

10701fe

## OPERATION

midfrequencies in the energy storage inductor. This greatly simplifies closed-loop frequency compensation under widely varying input voltage or output load conditions. Finally, it allows simple pulse-by-pulse current limiting to provide maximum switch protection under output overload or short-circuit conditions. A low drop-out internal regulator provides a 2.3V supply for all internal circuitry of the LT1070/LT1071. This low drop-out design allows input voltage to vary from 3V to 60V with virtually no change in device performance. A 40kHz oscillator is the basic clock for all internal timing. It turns “on” the output switch via the logic and driver circuitry. Special adaptive antisat circuitry detects onset of saturation in the power switch and adjusts driver current instantaneously to limit switch saturation. This minimizes driver dissipation and provides very rapid turn-off of the switch.

A 1.2V bandgap reference biases the positive input of the error amplifier. The negative input is brought out for output voltage sensing. This feedback pin has a second function; when pulled low with an external resistor, it programs the LT1070/LT1071 to disconnect the main error amplifier output and connects the output of the flyback amplifier to the comparator input. The LT1070/LT1071 will then regulate the value of the flyback pulse with respect to the supply voltage. This flyback pulse is directly proportional to output voltage in the traditional

transformer coupled flyback topology regulator. By regulating the amplitude of the flyback pulse, the output voltage can be regulated with no direct connection between input and output. The output is fully floating up to the breakdown voltage of the transformer windings. Multiple floating outputs are easily obtained with additional windings. A special delay network inside the LT1070/LT1071 ignores the leakage inductance spike at the leading edge of the flyback pulse to improve output regulation.

The error signal developed at the comparator input is brought out externally. This pin ( $V_C$ ) has four different functions. It is used for frequency compensation, current limit adjustment, soft starting and total regulator shutdown. During normal regulator operation this pin sits at a voltage between 0.9V (low output current) and 2.0V (high output current). The error amplifiers are current output ( $g_m$ ) types, so this voltage can be externally clamped for adjusting current limit. Likewise, a capacitor coupled external clamp will provide soft start. Switch duty cycle goes to zero if the  $V_C$  pin is pulled to ground through a diode, placing the LT1070/LT1071 in an idle mode. Pulling the  $V_C$  pin below 0.15V causes total regulator shutdown, with only 50 $\mu$ A supply current for shutdown circuitry biasing. See AN19 for full application details.

## TYPICAL APPLICATIONS (Note that maximum output currents are divided by 2 for the LT1071)

Driving High Voltage FET (for Off-Line Applications, See AN25)

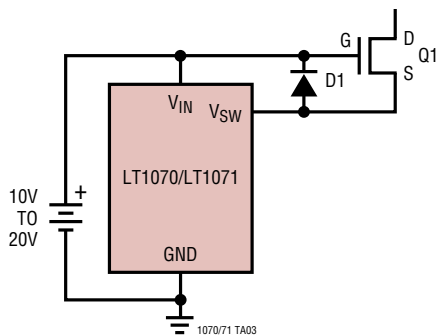

Driving High Voltage NPN

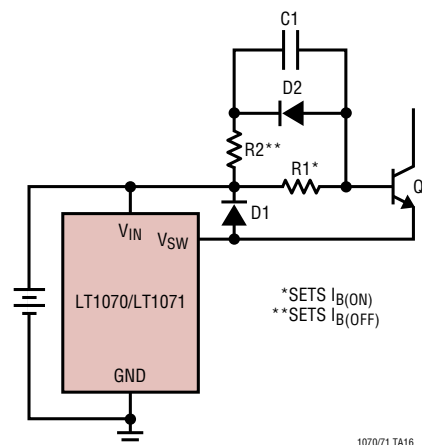



**TYPICAL APPLICATIONS** (Note that maximum output currents are divided by 2 for the LT1071)

**Negative Buck Converter**

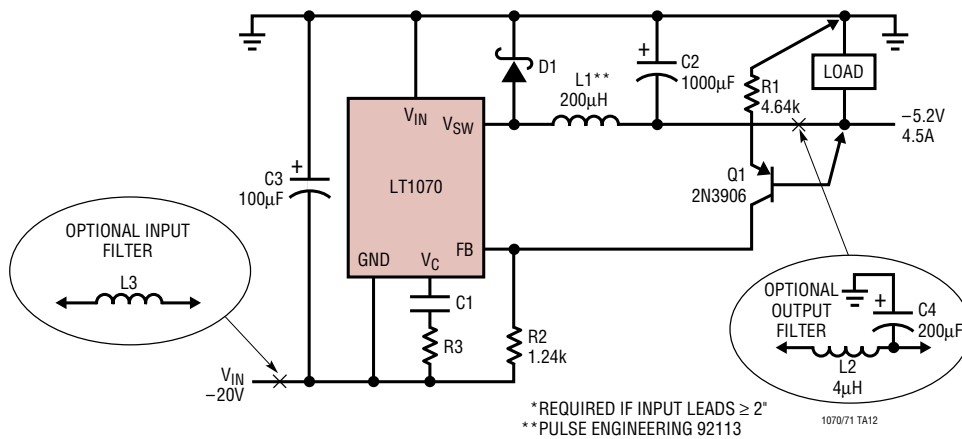

**Positive Buck Converter**

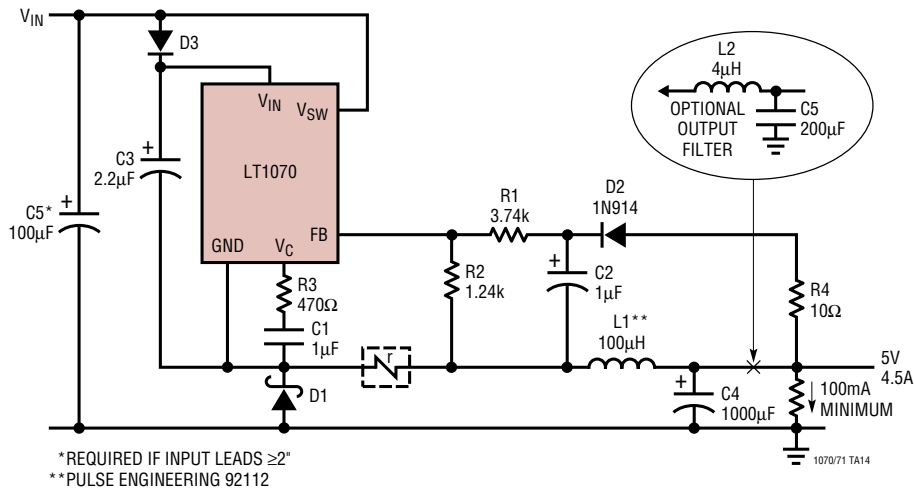

**Negative Current Boosted Buck Converter**

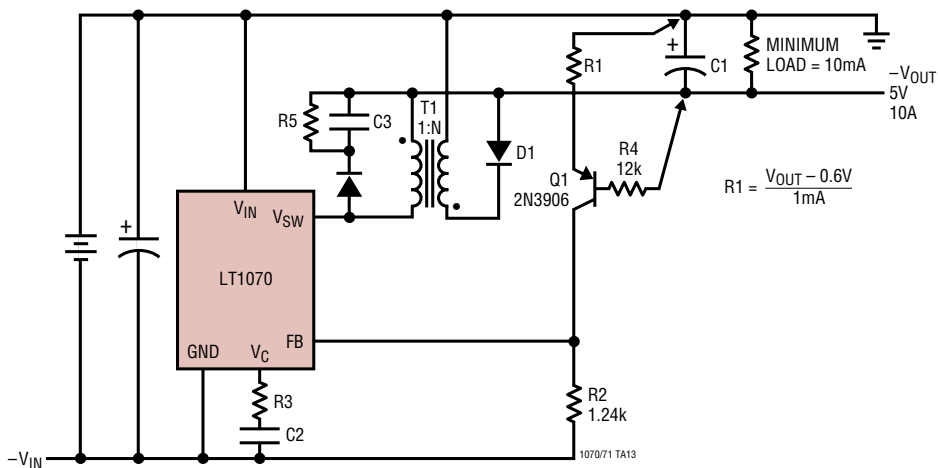



**TYPICAL APPLICATIONS** (Note that maximum output currents are divided by 2 for the LT1071)

**Positive Current Boosted Buck Converter**

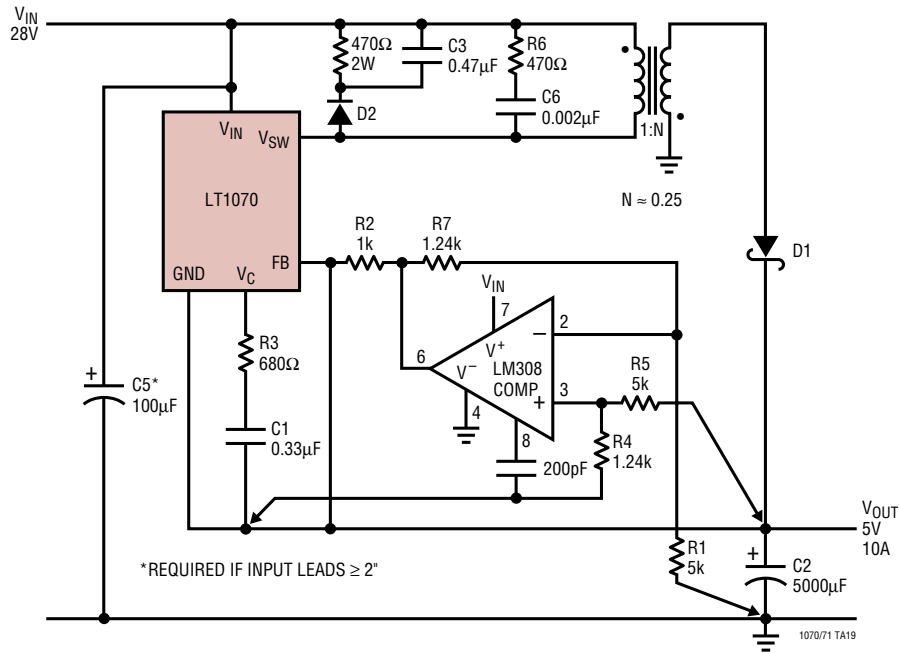

**Negative to Positive Buck/Boost Converter**

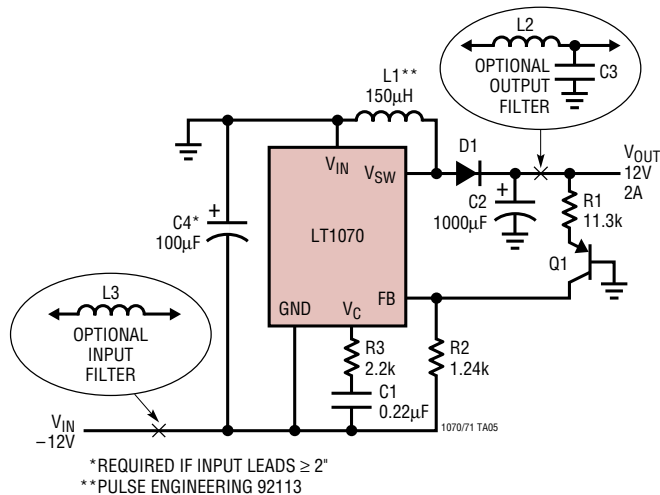

**Positive to Negative Buck/Boost Converter**

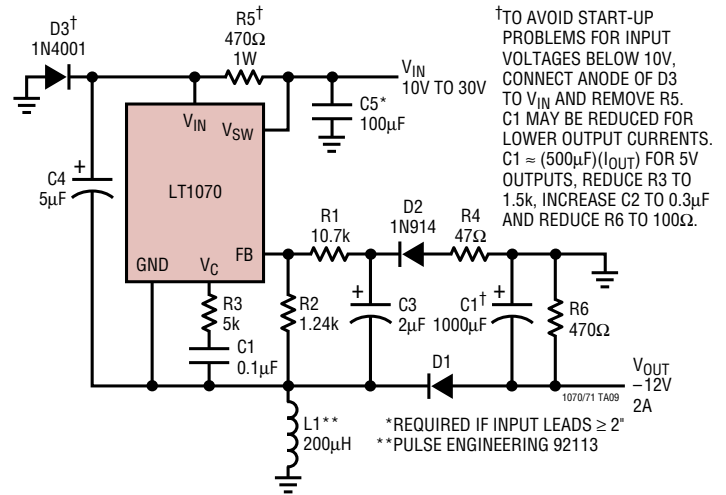

## TYPICAL APPLICATIONS (Note that maximum output currents are divided by 2 for the LT1071)

### Voltage Boosted Boost Converter

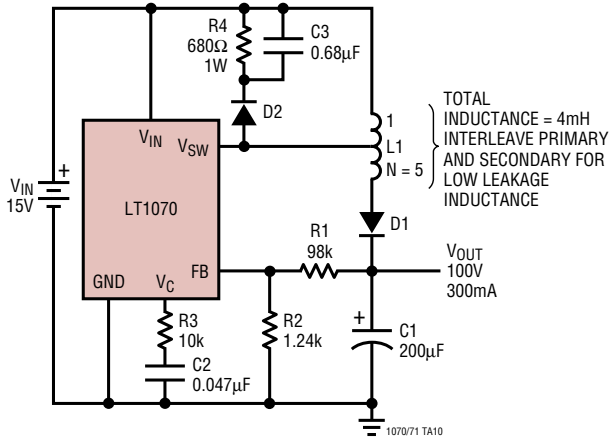

### Current Boosted Boost Converter

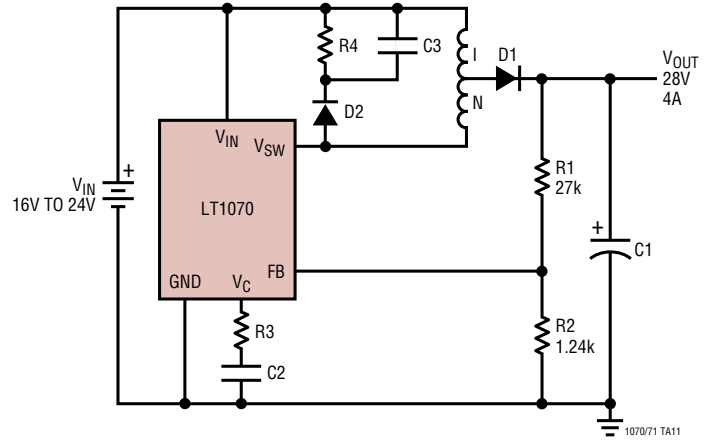

### Negative Boost Regulator

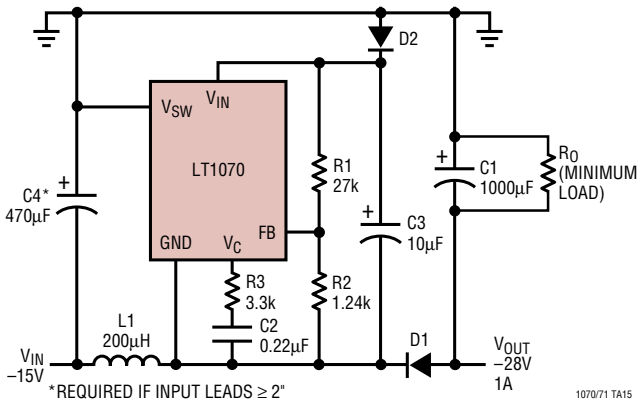

### Negative Input/Negative Output Flyback Converter

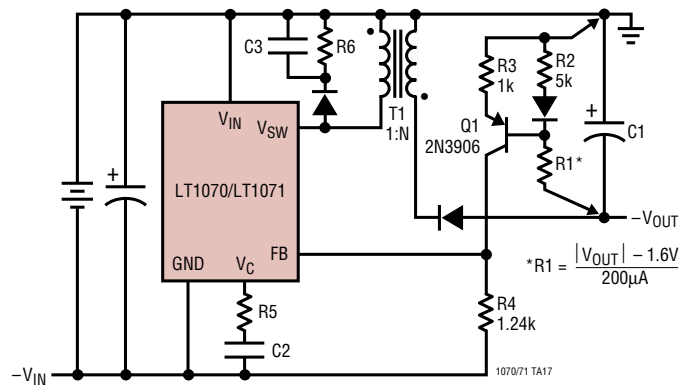

### External Current Limit

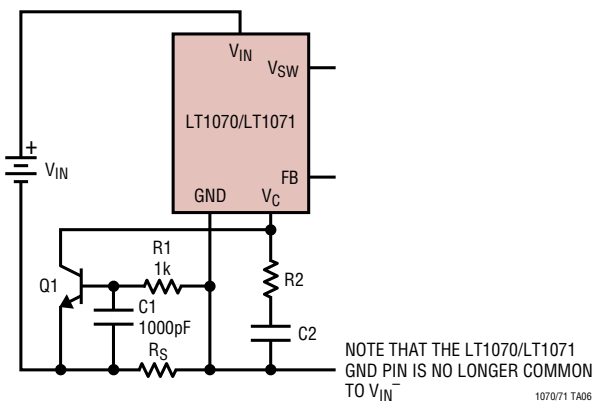

### External Current Limit

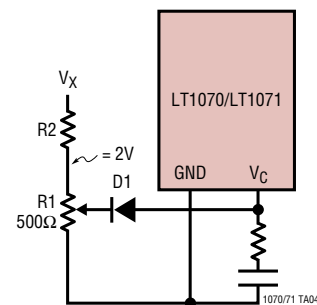

# TYPICAL APPLICATIONS (Note that maximum output currents are divided by 2 for the LT1071)

## Flyback Converter

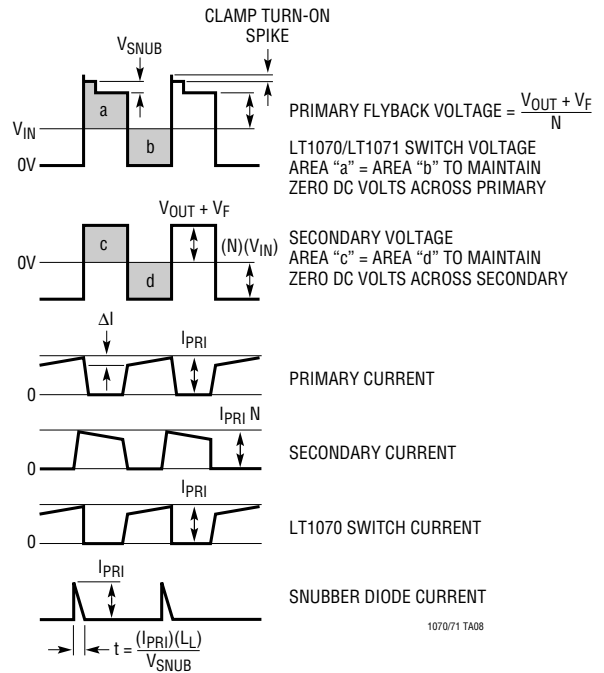
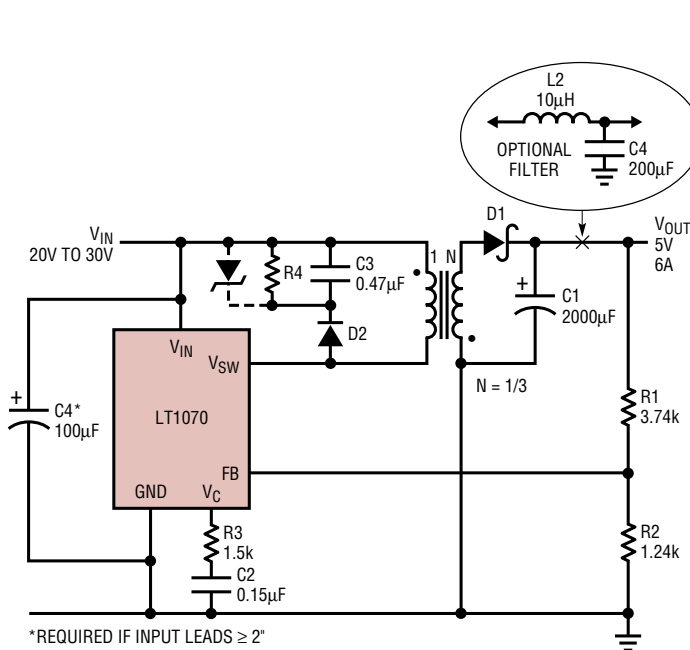

## PACKAGE DESCRIPTION

**K Package**  
4-Lead TO-3 Metal Can  
(Reference LTC DWG # 05-08-1311)

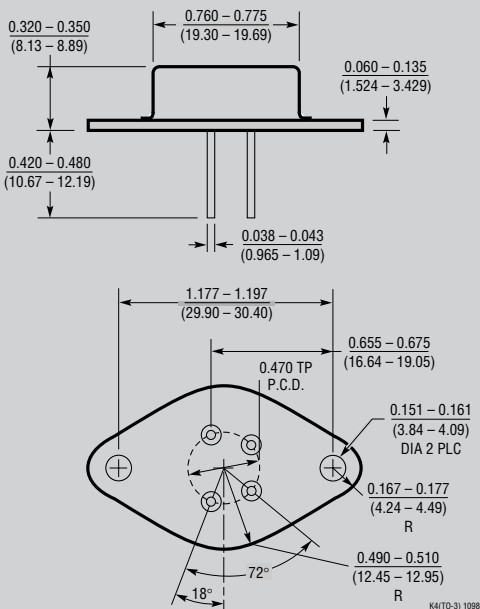

**OBsolete PACKAGE**

**T Package**  
5-Lead Plastic TO-220 (Standard)  
(Reference LTC DWG # 05-08-1421)

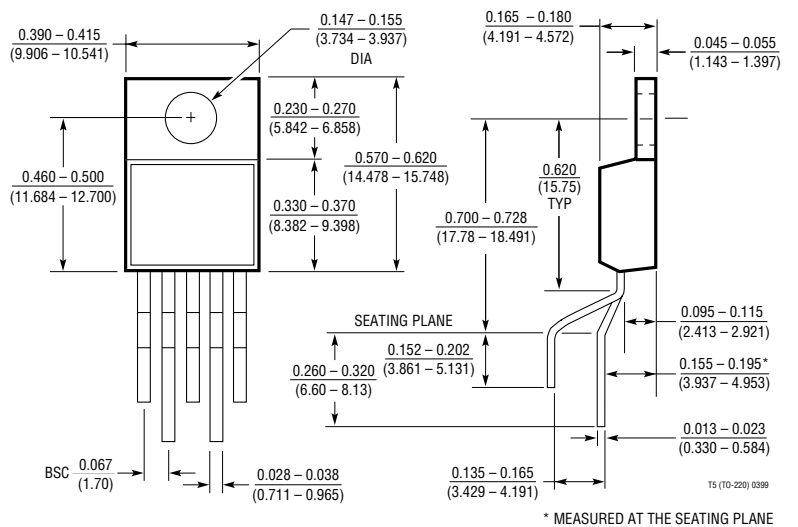

\* MEASURED AT THE SEATING PLANE

**TYPICAL APPLICATIONS** (Note that maximum output currents are divided by 2 for the LT1071)

**Totally Isolated Converter**

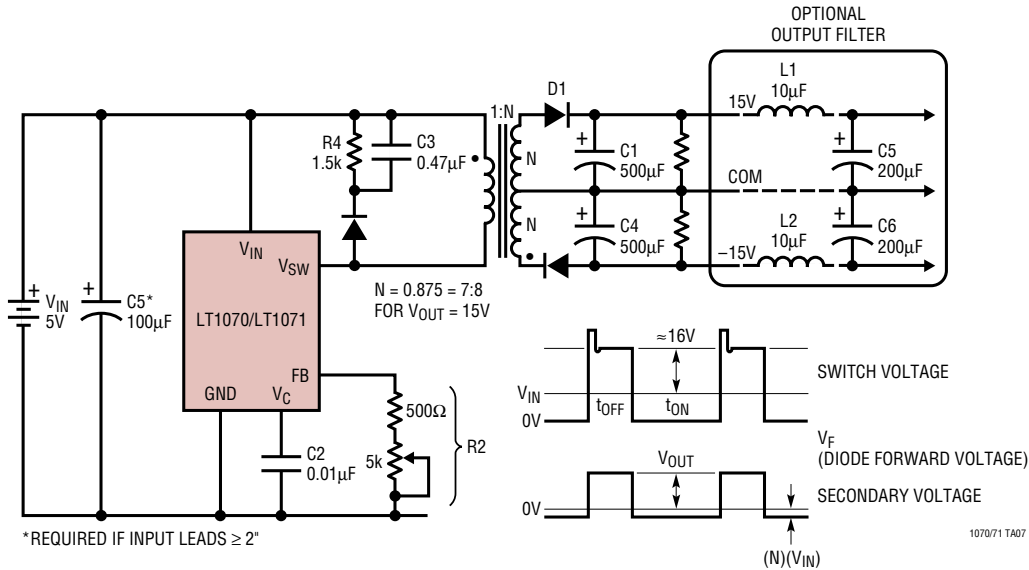

**Forward Converter**

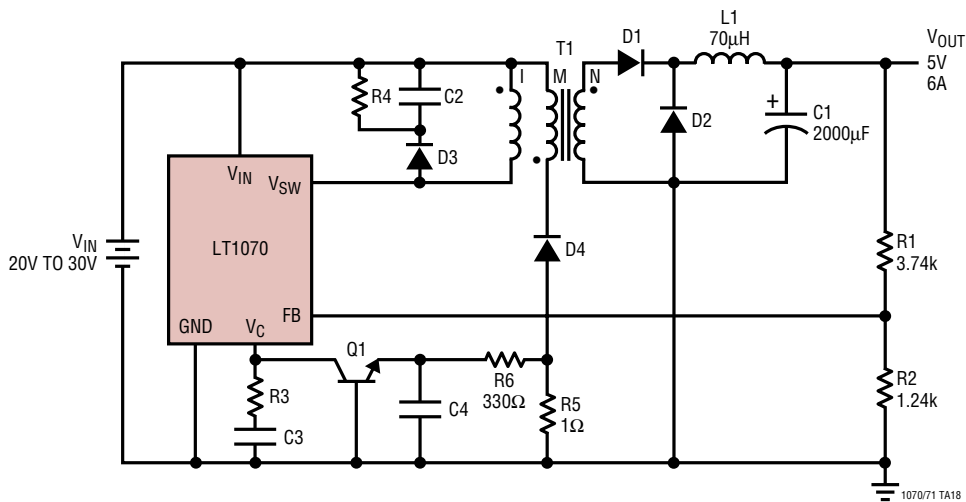

**RELATED PARTS**

PART NUMBER	DESCRIPTION	COMMENTS
LT1074/LT1076	High Voltage Switching Regulators	40V Input (60V for HV Versions), 100kHz, 5A and 2A
LT1170/LT1171/ LT1172	100kHz High Efficiency Switching Regulators	40V Input (65V for HV Versions), 5A/2.5A/1.25A Internal Switch
LT1370/LT1371	500kHz High Efficiency Switching Regulators	35V, 6A/3A Internal Switch
LT1374/LT1376	100kHz High Efficiency Switching Regulators	25V Input, 4.5A/1.5A Internal Switch
LT1765	1.25MHz, 3A, Step-Down Regulator	25V Input, TSSOP-16E, S08 Package

10701fe