



LPC1311/13/42/43

32-bit ARM Cortex-M3 microcontroller; up to 32 kB flash and 8 kB SRAM; USB device

Rev. 5 — 6 June 2012

Product data sheet

1. General description

The LPC1311/13/42/43 are ARM Cortex-M3 based microcontrollers for embedded applications featuring a high level of integration and low power consumption. The ARM Cortex-M3 is a next generation core that offers system enhancements such as enhanced debug features and a higher level of support block integration.

The LPC1311/13/42/43 operate at CPU frequencies of up to 72 MHz. The ARM Cortex-M3 CPU incorporates a 3-stage pipeline and uses a Harvard architecture with separate local instruction and data buses as well as a third bus for peripherals. The ARM Cortex-M3 CPU also includes an internal prefetch unit that supports speculative branching.

The peripheral complement of the LPC1311/13/42/43 includes up to 32 kB of flash memory, up to 8 kB of data memory, USB Device (LPC1342/43 only), one Fast-mode Plus I²C-bus interface, one UART, four general purpose timers, and up to 42 general purpose I/O pins.

Remark: The LPC1311/13/42/43 series consists of the LPC1300 series (parts LPC1311/13/42/43) and the LPC1300L series (parts LPC1311/01 and LPC1313/01). The LPC1300L series features the following enhancements over the LPC1300 series:

- Power profiles with lower power consumption in Active and Sleep modes.
- Four levels for BOD forced reset.
- Second SSP controller (LPC1313FBD48/01 only).
- Windowed Watchdog Timer (WWDT).
- Internal pull-up resistors pull up pins to full V_{DD} level.
- Programmable pseudo open-drain mode for GPIO pins.

2. Features and benefits

- ARM Cortex-M3 processor, running at frequencies of up to 72 MHz.
- ARM Cortex-M3 built-in Nested Vectored Interrupt Controller (NVIC).
- 32 kB (LPC1343/13)/16 kB (LPC1342)/8 kB (LPC1311) on-chip flash programming memory.
- 8 kB (LPC1343/13)/4 kB (LPC1342/11) SRAM.
- In-System Programming (ISP) and In-Application Programming (IAP) via on-chip bootloader software.
- Selectable boot-up: UART or USB (USB on LPC1342/43 only).
- On LPC1342/43: USB MSC and HID on-chip drivers.



- Serial interfaces:
 - ◆ USB 2.0 full-speed device controller with on-chip PHY for device (LPC1342/43 only).
 - ◆ UART with fractional baud rate generation, modem, internal FIFO, and RS-485/EIA-485 support.
 - ◆ SSP controller with FIFO and multi-protocol capabilities.
 - ◆ Additional SSP controller on LPC1313FBD48/01.
 - ◆ I²C-bus interface supporting full I²C-bus specification and Fast-mode Plus with a data rate of 1 Mbit/s with multiple address recognition and monitor mode.
- Other peripherals:
 - ◆ Up to 42 General Purpose I/O (GPIO) pins with configurable pull-up/pull-down resistors.
 - ◆ Four general purpose counter/timers with a total of four capture inputs and 13 match outputs.
 - ◆ Programmable WatchDog Timer (WDT).
 - ◆ Programmable Windowed Watchdog Timer (WWDT) on LPC1311/01 and LPC1313/01.
 - ◆ System tick timer.
- Serial Wire Debug and Serial Wire Trace port.
- High-current output driver (20 mA) on one pin.
- High-current sink drivers (20 mA) on two I²C-bus pins in Fast-mode Plus.
- Integrated PMU (Power Management Unit) to minimize power consumption during Sleep, Deep-sleep, and Deep power-down modes.
- Power profiles residing in boot ROM allowing to optimize performance and minimize power consumption for any given application through one simple function call. (LPC1300L series, on LPC1311/01 and LPC1313/01 only.)
- Three reduced power modes: Sleep, Deep-sleep, and Deep power-down.
- Single power supply (2.0 V to 3.6 V).
- 10-bit ADC with input multiplexing among 8 pins.
- GPIO pins can be used as edge and level sensitive interrupt sources.
- Clock output function with divider that can reflect the system oscillator clock, IRC clock, CPU clock, or the watchdog clock.
- Processor wake-up from Deep-sleep mode via a dedicated start logic using up to 40 of the functional pins.
- Brownout detect with four separate thresholds for interrupt and one threshold for forced reset (four thresholds for forced reset on the LPC1311/01 and LPC1313/01 parts).
- Power-On Reset (POR).
- Integrated oscillator with an operating range of 1 MHz to 25 MHz.
- 12 MHz internal RC oscillator trimmed to 1 % accuracy over the entire temperature and voltage range that can optionally be used as a system clock.
- Programmable watchdog oscillator with a frequency range of 7.8 kHz to 1.8 MHz.
- System PLL allows CPU operation up to the maximum CPU rate without the need for a high-frequency crystal. May be run from the system oscillator or the internal RC oscillator.
- For USB (LPC1342/43), a second, dedicated PLL is provided.
- Code Read Protection (CRP) with different security levels.

- Unique device serial number for identification.
- Available as 48-pin LQFP package and 33-pin HVQFN package.

3. Applications

- eMetering
- Lighting
- Alarm systems
- White goods

4. Ordering information

Table 1. Ordering information

Type number	Package		
	Name	Description	Version
LPC1311FHN33	HVQFN33	HVQFN33: plastic thermal enhanced very thin quad flat package; no leads; 33 terminals; body 7 × 7 × 0.85 mm	n/a
LPC1311FHN33/01	HVQFN33	HVQFN33: plastic thermal enhanced very thin quad flat package; no leads; 33 terminals; body 7 × 7 × 0.85 mm	n/a
LPC1313FHN33	HVQFN33	HVQFN33: plastic thermal enhanced very thin quad flat package; no leads; 33 terminals; body 7 × 7 × 0.85 mm	n/a
LPC1313FHN33/01	HVQFN33	HVQFN33: plastic thermal enhanced very thin quad flat package; no leads; 33 terminals; body 7 × 7 × 0.85 mm	n/a
LPC1313FBD48	LQFP48	LQFP48: plastic low profile quad flat package; 48 leads; body 7 × 7 × 1.4 mm	SOT313-2
LPC1313FBD48/01	LQFP48	LQFP48: plastic low profile quad flat package; 48 leads; body 7 × 7 × 1.4 mm	SOT313-2
LPC1342FHN33	HVQFN33	HVQFN33: plastic thermal enhanced very thin quad flat package; no leads; 33 terminals; body 7 × 7 × 0.85 mm	n/a
LPC1342FBD48	LQFP48	LQFP48: plastic low profile quad flat package; 48 leads; body 7 × 7 × 1.4 mm	SOT313-2
LPC1343FHN33	HVQFN33	HVQFN33: plastic thermal enhanced very thin quad flat package; no leads; 33 terminals; body 7 × 7 × 0.85 mm	n/a
LPC1343FBD48	LQFP48	LQFP48: plastic low profile quad flat package; 48 leads; body 7 × 7 × 1.4 mm	SOT313-2

4.1 Ordering options

Table 2. Ordering options for LPC1311/13/42/43

Type number	Flash	Total SRAM	USB	Power profiles	UART RS-485	I ² C/ Fast+	SSP	ADC channels	Pins	Package
LPC1311FHN33	8 kB	4 kB	-	no	1	1	1	8	33	HVQFN33
LPC1311FHN33/01	8 kB	4 kB	-	yes	1	1	1	8	33	HVQFN33
LPC1313FHN33	32 kB	8 kB	-	no	1	1	1	8	33	HVQFN33
LPC1313FHN33/01	32 kB	8 kB	-	yes	1	1	1	8	33	HVQFN33
LPC1313FBD48	32 kB	8 kB	-	no	1	1	1	8	48	LQFP48
LPC1313FBD48/01	32 kB	8 kB	-	yes	1	1	2	8	48	LQFP48

Table 2. Ordering options for LPC1311/13/42/43 ...continued

Type number	Flash	Total SRAM	USB	Power profiles	UART RS-485	I ² C/ Fast+	SSP	ADC channels	Pins	Package
LPC1342FHN33	16 kB	4 kB	Device	no	1	1	1	8	33	HVQFN33
LPC1342FBD48	16 kB	4 kB	Device	no	1	1	1	8	48	LQFP48
LPC1343FHN33	32 kB	8 kB	Device	no	1	1	1	8	33	HVQFN33
LPC1343FBD48	32 kB	8 kB	Device	no	1	1	1	8	48	LQFP48

5. Block diagram

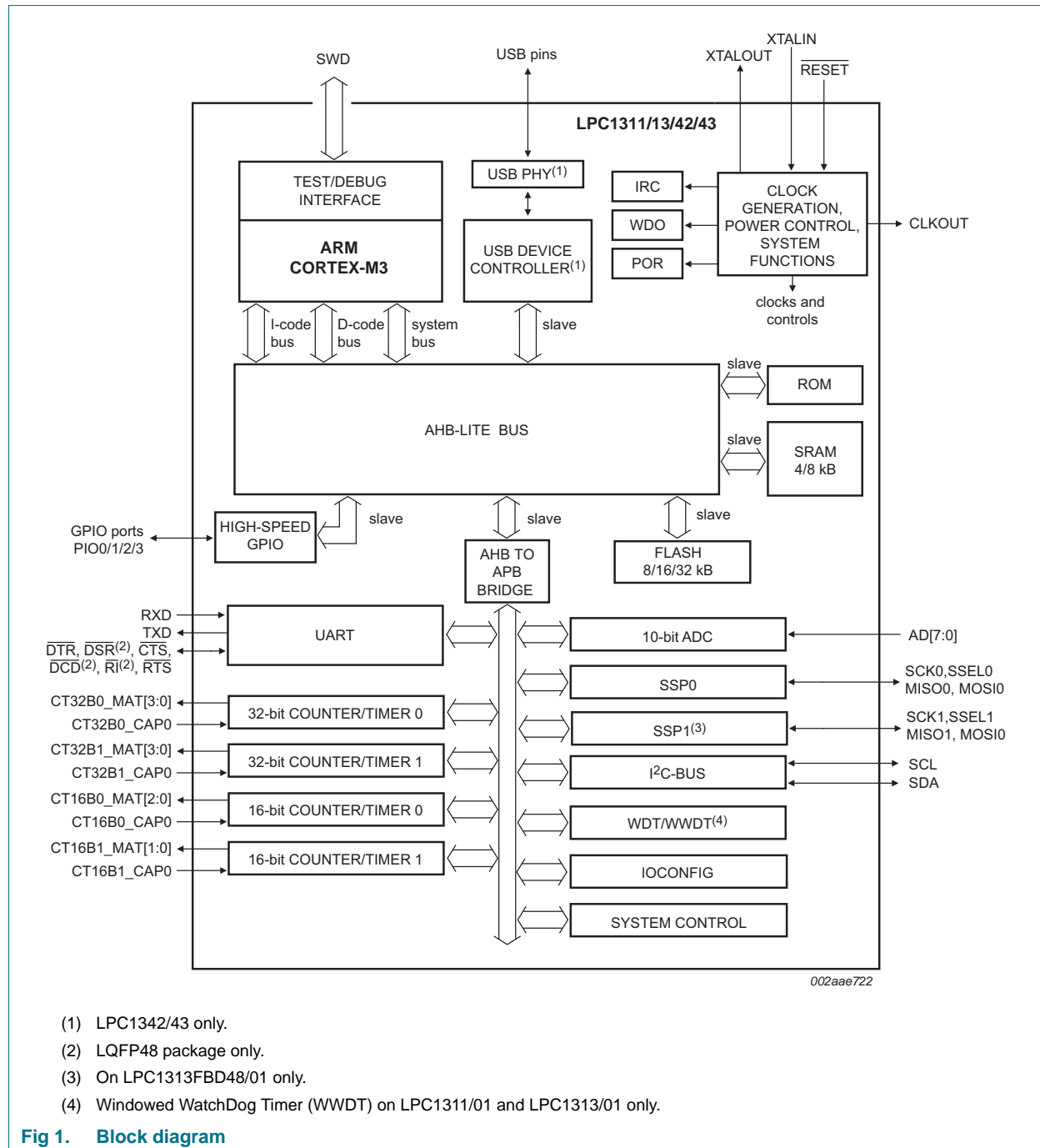

6. Pinning information

6.1 Pinning

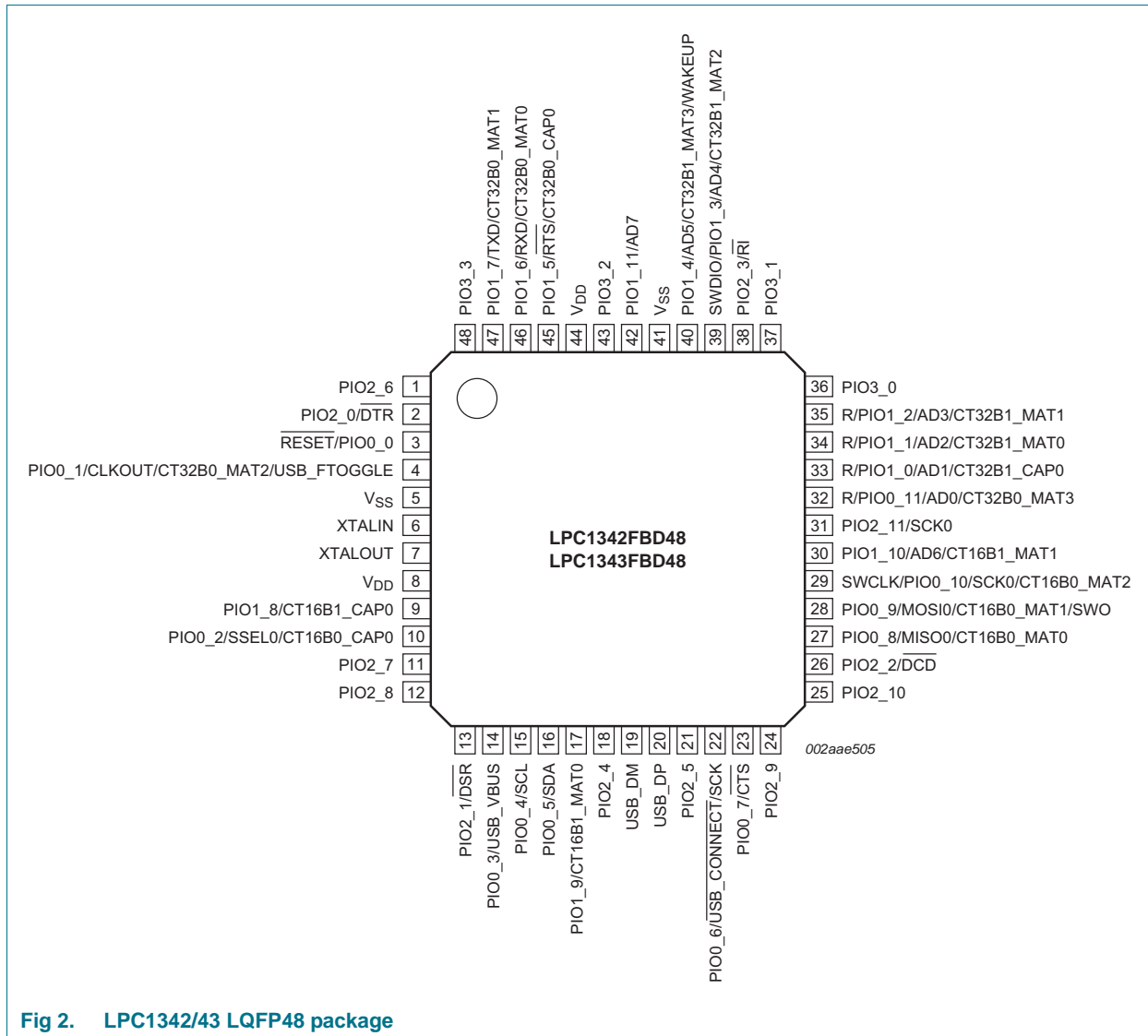

Fig 2. LPC1342/43 LQFP48 package

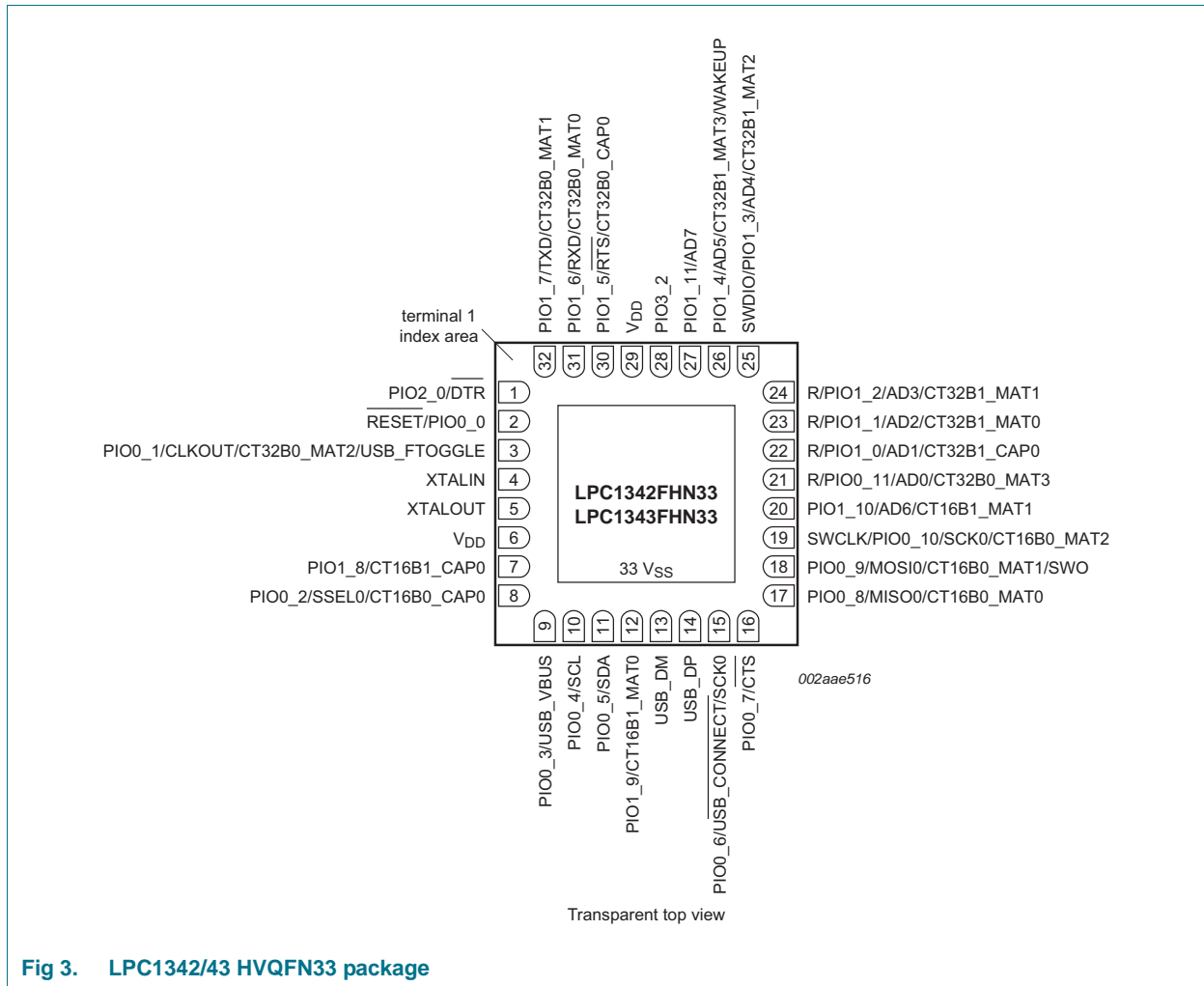
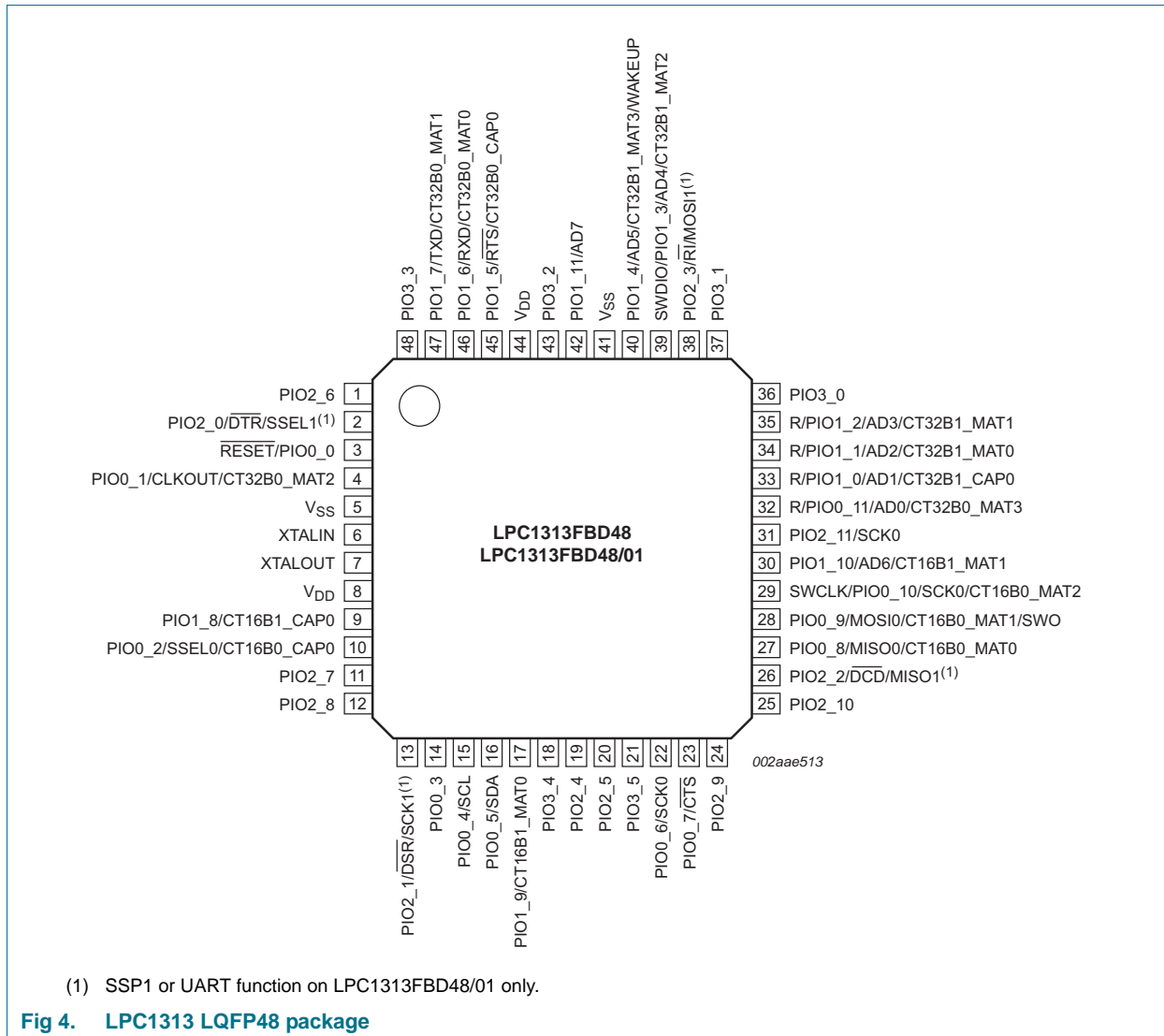

Fig 3. LPC1342/43 HVQFN33 package



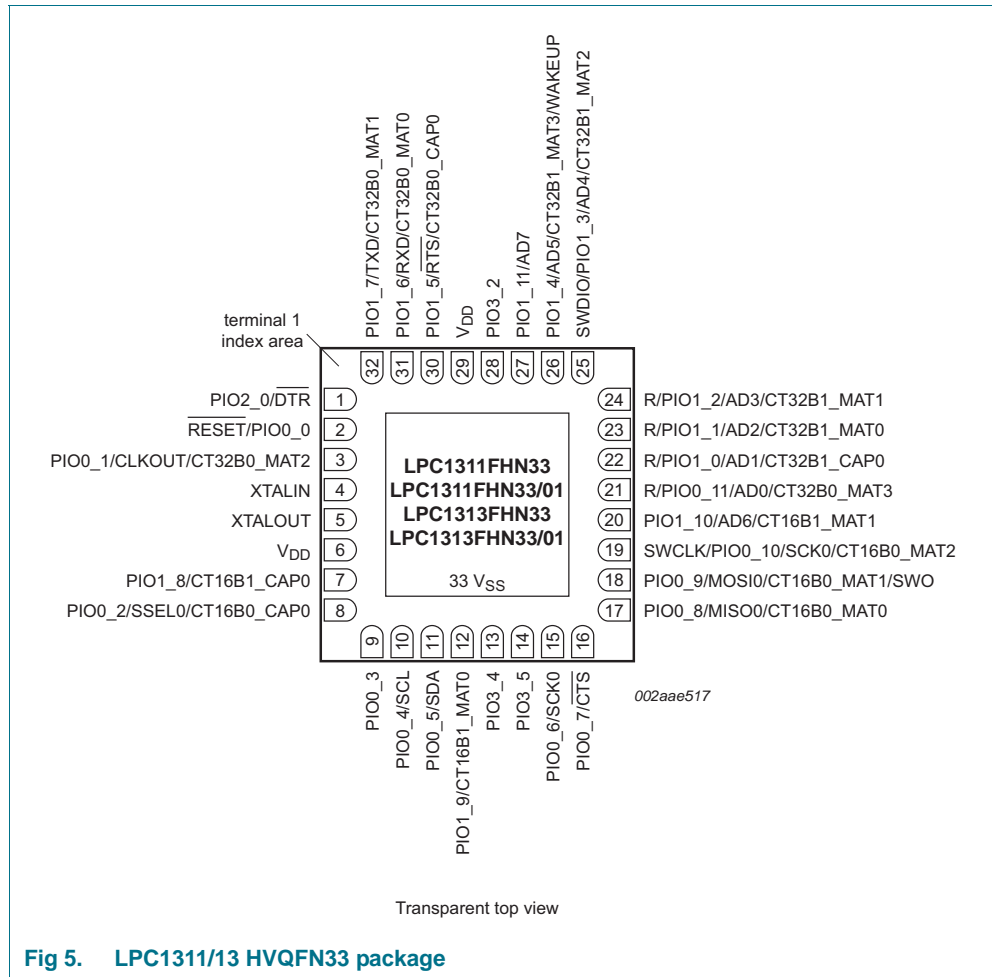

Fig 5. LPC1311/13 HVQFN33 package

6.2 Pin description

Table 3. LPC1313/42/43 LQFP48 pin description table

Symbol	Pin	Start logic input	Type	Reset state [1]	Description
RESET/PIO0_0	3 ^[2]	yes	I	I; PU	RESET — External reset input with 20 ns glitch filter. A LOW-going pulse as short as 50 ns on this pin resets the device, causing I/O ports and peripherals to take on their default states, and processor execution to begin at address 0.
			I/O	-	PIO0_0 — General purpose digital input/output pin with 10 ns glitch filter.
PIO0_1/CLKOUT/ CT32B0_MAT2/ USB_FTOGGLE	4 ^[3]	yes	I/O	I; PU	PIO0_1 — General purpose digital input/output pin. A LOW level on this pin during reset starts the ISP command handler or the USB device enumeration (USB on LPC1342/43 only, see description of PIO0_3).
			O	-	CLKOUT — Clockout pin.
			O	-	CT32B0_MAT2 — Match output 2 for 32-bit timer 0.
			O	-	USB_FTOGGLE — USB 1 ms Start-of-Frame signal (LPC1342/43 only).
PIO0_2/SSEL0/ CT16B0_CAP0	10 ^[3]	yes	I/O	I; PU	PIO0_2 — General purpose digital input/output pin.
			I/O	-	SSEL0 — Slave select for SSP0.
			I	-	CT16B0_CAP0 — Capture input 0 for 16-bit timer 0.
PIO0_3/USB_VBUS	14 ^[3]	yes	I/O	I; PU	PIO0_3 — General purpose digital input/output pin. LPC1342/43 only: A LOW level on this pin during reset starts the ISP command handler, a HIGH level starts the USB device enumeration.
			I	-	USB_VBUS — Monitors the presence of USB bus power (LPC1342/43 only).
PIO0_4/SCL	15 ^[4]	yes	I/O	I; IA	PIO0_4 — General purpose digital input/output pin (open-drain).
			I/O	-	SCL — I ² C-bus clock input/output (open-drain). High-current sink only if I ² C Fast-mode Plus is selected in the I/O configuration register.
PIO0_5/SDA	16 ^[4]	yes	I/O	I; IA	PIO0_5 — General purpose digital input/output pin (open-drain).
			I/O	-	SDA — I ² C-bus data input/output (open-drain). High-current sink only if I ² C Fast-mode Plus is selected in the I/O configuration register.
PIO0_6/ USB_CONNECT/ SCK0	22 ^[3]	yes	I/O	I; PU	PIO0_6 — General purpose digital input/output pin.
			O	-	USB_CONNECT — Signal used to switch an external 1.5 kΩ resistor under software control. Used with the SoftConnect USB feature (LPC1342/43 only).
			I/O	-	SCK0 — Serial clock for SSP0.
PIO0_7/CTS	23 ^[3]	yes	I/O	I; PU	PIO0_7 — General purpose digital input/output pin (high-current output driver).
			I	-	CTS — Clear To Send input for UART.
PIO0_8/MISO0/ CT16B0_MAT0	27 ^[3]	yes	I/O	I; PU	PIO0_8 — General purpose digital input/output pin.
			I/O	-	MISO0 — Master In Slave Out for SSP0.
			O	-	CT16B0_MAT0 — Match output 0 for 16-bit timer 0.

Table 3. LPC1313/42/43 LQFP48 pin description table ...continued

Symbol	Pin	Start logic input	Type	Reset state [1]	Description
PIO0_9/MOSI0/ CT16B0_MAT1/ SWO	28 ^[5]	yes	I/O	I; PU	PIO0_9 — General purpose digital input/output pin.
			I/O	-	MOSI0 — Master Out Slave In for SSP0.
			O	-	CT16B0_MAT1 — Match output 1 for 16-bit timer 0.
			O	-	SWO — Serial wire trace output.
SWCLK/PIO0_10/ SCK0/CT16B0_MAT2	29 ^[5]	yes	I	I; PU	SWCLK — Serial wire clock.
			I/O	-	PIO0_10 — General purpose digital input/output pin.
			I/O	-	SCK0 — Serial clock for SSP0.
			O	-	CT16B0_MAT2 — Match output 2 for 16-bit timer 0.
R/PIO0_11/ AD0/CT32B0_MAT3	32 ^[5]	yes	-	I; PU	R — Reserved. Configure for an alternate function in the IOCONFIG block.
			I/O	-	PIO0_11 — General purpose digital input/output pin.
			I	-	AD0 — A/D converter, input 0.
			O	-	CT32B0_MAT3 — Match output 3 for 32-bit timer 0.
R/PIO1_0/ AD1/CT32B1_CAP0	33 ^[5]	yes	-	I; PU	R — Reserved. Configure for an alternate function in the IOCONFIG block.
			I/O	-	PIO1_0 — General purpose digital input/output pin.
			I	-	AD1 — A/D converter, input 1.
			I	-	CT32B1_CAP0 — Capture input 0 for 32-bit timer 1.
R/PIO1_1/ AD2/CT32B1_MAT0	34 ^[5]	yes	-	I; PU	R — Reserved. Configure for an alternate function in the IOCONFIG block.
			I/O	-	PIO1_1 — General purpose digital input/output pin.
			I	-	AD2 — A/D converter, input 2.
			O	-	CT32B1_MAT0 — Match output 0 for 32-bit timer 1.
R/PIO1_2/ AD3/CT32B1_MAT1	35 ^[5]	yes	-	I; PU	R — Reserved. Configure for an alternate function in the IOCONFIG block.
			I/O	-	PIO1_2 — General purpose digital input/output pin.
			I	-	AD3 — A/D converter, input 3.
			O	-	CT32B1_MAT1 — Match output 1 for 32-bit timer 1.
SWDIO/PIO1_3/ AD4/ CT32B1_MAT2	39 ^[5]	yes	I/O	I; PU	SWDIO — Serial wire debug input/output.
			I/O	-	PIO1_3 — General purpose digital input/output pin.
			I	-	AD4 — A/D converter, input 4.
			O	-	CT32B1_MAT2 — Match output 2 for 32-bit timer 1.
PIO1_4/AD5/ CT32B1_MAT3/ WAKEUP	40 ^[5]	yes	I/O	I; PU	PIO1_4 — General purpose digital input/output pin.
			I	-	AD5 — A/D converter, input 5.
			O	-	CT32B1_MAT3 — Match output 3 for 32-bit timer 1.
			I	-	WAKEUP — Deep power-down mode wake-up pin with 20 ns glitch filter. This pin must be pulled HIGH externally to enter Deep power-down mode and pulled LOW to exit Deep power-down mode. A LOW-going pulse as short as 50 ns wakes up the part.

Table 3. LPC1313/42/43 LQFP48 pin description table ...continued

Symbol	Pin	Start logic input	Type	Reset state [1]	Description
PIO1_5/ $\overline{\text{RTS}}$ / CT32B0_CAP0	45[3]	yes	I/O	I; PU	PIO1_5 — General purpose digital input/output pin.
			O	-	RTS — Request To Send output for UART.
			I	-	CT32B0_CAP0 — Capture input 0 for 32-bit timer 0.
PIO1_6/RXD/ CT32B0_MAT0	46[3]	yes	I/O	I; PU	PIO1_6 — General purpose digital input/output pin.
			I	-	RXD — Receiver input for UART.
			O	-	CT32B0_MAT0 — Match output 0 for 32-bit timer 0.
PIO1_7/TXD/ CT32B0_MAT1	47[3]	yes	I/O	I; PU	PIO1_7 — General purpose digital input/output pin.
			O	-	TXD — Transmitter output for UART.
			O	-	CT32B0_MAT1 — Match output 1 for 32-bit timer 0.
PIO1_8/CT16B1_CAP0	9[3]	yes	I/O	I; PU	PIO1_8 — General purpose digital input/output pin.
			I	-	CT16B1_CAP0 — Capture input 0 for 16-bit timer 1.
PIO1_9/CT16B1_MAT0	17[3]	yes	I/O	I; PU	PIO1_9 — General purpose digital input/output pin.
			O	-	CT16B1_MAT0 — Match output 0 for 16-bit timer 1.
PIO1_10/AD6/ CT16B1_MAT1	30[5]	yes	I/O	I; PU	PIO1_10 — General purpose digital input/output pin.
			I	-	AD6 — A/D converter, input 6.
			O	-	CT16B1_MAT1 — Match output 1 for 16-bit timer 1.
PIO1_11/AD7	42[5]	yes	I/O	I; PU	PIO1_11 — General purpose digital input/output pin.
			I	-	AD7 — A/D converter, input 7.
PIO2_0/ $\overline{\text{DTR}}$ /SSEL1	2[3]	yes	I/O	I; PU	PIO2_0 — General purpose digital input/output pin.
			O	-	DTR — Data Terminal Ready output for UART.
			I/O	-	SSEL1 — Slave Select for SSP1 (LPC1313FBD48/01 only).
PIO2_1/ $\overline{\text{DSR}}$ /SCK1	13[3]	yes	I/O	I; PU	PIO2_1 — General purpose digital input/output pin.
			I	-	DSR — Data Set Ready input for UART.
			I/O	-	SCK1 — Serial clock for SSP1 (LPC1313FBD48/01 only).
PIO2_2/ $\overline{\text{DCD}}$ /MISO1	26[3]	yes	I/O	I; PU	PIO2_2 — General purpose digital input/output pin.
			I	-	DCD — Data Carrier Detect input for UART.
			I/O	-	MISO1 — Master In Slave Out for SSP1 (LPC1313FBD48/01 only).
PIO2_3/ $\overline{\text{RI}}$ /MOSI1	38[3]	yes	I/O	I; PU	PIO2_3 — General purpose digital input/output pin.
			I	-	RI — Ring Indicator input for UART.
			I/O	-	MOSI1 — Master Out Slave In for SSP1 (LPC1313FBD48/01 only).
PIO2_4	18[3]	yes	I/O	I; PU	PIO2_4 — General purpose digital input/output pin (LPC1342/43 only).
PIO2_4	19[3]	yes	I/O	I; PU	PIO2_4 — General purpose digital input/output pin (LPC1313 only).
PIO2_5	21[3]	yes	I/O	I; PU	PIO2_5 — General purpose digital input/output pin (LPC1342/43 only).
PIO2_5	20[3]	yes	I/O	I; PU	PIO2_5 — General purpose digital input/output pin (LPC1313 only).
PIO2_6	1[3]	yes	I/O	I; PU	PIO2_6 — General purpose digital input/output pin.
PIO2_7	11[3]	yes	I/O	I; PU	PIO2_7 — General purpose digital input/output pin.
PIO2_8	12[3]	yes	I/O	I; PU	PIO2_8 — General purpose digital input/output pin.
PIO2_9	24[3]	yes	I/O	I; PU	PIO2_9 — General purpose digital input/output pin.

Table 3. LPC1313/42/43 LQFP48 pin description table ...continued

Symbol	Pin	Start logic input	Type	Reset state [1]	Description
PIO2_10	25[3]	yes	I/O	I; PU	PIO2_10 — General purpose digital input/output pin.
PIO2_11/SCK0	31[3]	yes	I/O	I; PU	PIO2_11 — General purpose digital input/output pin.
			I/O	-	SCK0 — Serial clock for SSP0.
PIO3_0/ $\overline{\text{DTR}}$	36[3]	yes	I/O	I; PU	PIO3_0 — General purpose digital input/output pin.
			O	-	$\overline{\text{DTR}}$ — Data Terminal Ready output for UART (LPC1311/01 and LPC1313/01 only).
PIO3_1/ $\overline{\text{DSR}}$	37[3]	yes	I/O	I; PU	PIO3_1 — General purpose digital input/output pin.
			I	-	$\overline{\text{DSR}}$ — Data Set Ready input for UART (LPC1311/01 and LPC1313/01 only).
PIO3_2/ $\overline{\text{DCD}}$	43[3]	yes	I/O	I; PU	PIO3_2 — General purpose digital input/output pin.
			I	-	$\overline{\text{DCD}}$ — Data Carrier Detect input for UART (LPC1311/01 and LPC1313/01 only).
PIO3_3/ $\overline{\text{RI}}$	48[3]	yes	I/O	I; PU	PIO3_3 — General purpose digital input/output pin.
			I	-	$\overline{\text{RI}}$ — Ring Indicator input for UART (LPC1311/01 and LPC1313/01 only).
PIO3_4	18[3]	no	I/O	I; PU	PIO3_4 — General purpose digital input/output pin (LPC1313 only).
PIO3_5	21[3]	no	I/O	I; PU	PIO3_5 — General purpose digital input/output pin (LPC1313 only).
USB_DM	19[6]	no	I/O	F	USB_DM — USB bidirectional D- line (LPC1342/43 only).
USB_DP	20[6]	no	I/O	F	USB_DP — USB bidirectional D+ line (LPC1342/43 only).
V _{DD}	8; 44	-	I	-	3.3 V supply voltage to the internal regulator, the external rail, and the ADC. Also used as the ADC reference voltage.
XTALIN	6[7]	-	I	-	Input to the oscillator circuit and internal clock generator circuits. Input voltage must not exceed 1.8 V.
XTALOUT	7[7]	-	O	-	Output from the oscillator amplifier.
V _{SS}	5; 41	-	I	-	Ground.

- [1] Pin state at reset for default function: I = Input; O = Output; PU = internal pull-up enabled (for V_{DD} = 3.3 V, pin is pulled up to 2.6 V for parts LPC1311/13/42/43 and pulled up to 3.3 V for parts LPC1311/01 and LPC1313/01); IA = inactive, no pull-up/down enabled; F = floating; floating pins, if not used, should be tied to ground or power to minimize power consumption.
- [2] 5 V tolerant pad. See [Figure 37](#) for pad characteristics. $\overline{\text{RESET}}$ functionality is not available in Deep power-down mode. Use the WAKEUP pin to reset the chip and wake up from Deep power-down mode. An external pull-up resistor is required on this pin for the Deep power-down mode.
- [3] 5 V tolerant pad providing digital I/O functions with configurable pull-up/pull-down resistors and configurable hysteresis (see [Figure 36](#)).
- [4] I²C-bus pads compliant with the I²C-bus specification for I²C standard mode and I²C Fast-mode Plus.
- [5] 5 V tolerant pad providing digital I/O functions with configurable pull-up/pull-down resistors, configurable hysteresis, and analog input. When configured as a ADC input, digital section of the pad is disabled and the pin is not 5 V tolerant (see [Figure 36](#)).
- [6] Pad provides USB functions. It is designed in accordance with the USB specification, revision 2.0 (Full-speed and Low-speed mode only). This pad is not 5 V tolerant.
- [7] When the system oscillator is not used, connect XTALIN and XTALOUT as follows: XTALIN can be left floating or can be grounded (grounding is preferred to reduce susceptibility to noise). XTALOUT should be left floating.

Table 4. LPC1311/13/42/43 HVQFN33 pin description table

Symbol	Pin	Start logic input	Type	Reset state [1]	Description
RESET/PIO0_0	2 [2]	yes	I	I; PU	RESET — External reset input with 20 ns glitch filter. A LOW-going pulse as short as 50 ns on this pin resets the device, causing I/O ports and peripherals to take on their default states, and processor execution to begin at address 0.
			I/O	-	PIO0_0 — General purpose digital input/output pin with 10 ns glitch filter.
PIO0_1/CLKOUT/ CT32B0_MAT2/ USB_FTOGGLE	3 [3]	yes	I/O	I; PU	PIO0_1 — General purpose digital input/output pin. A LOW level on this pin during reset starts the ISP command handler or the USB device enumeration (USB on LPC1342/43 only, see description of PIO0_3).
			O	-	CLKOUT — Clock out pin.
			O	-	CT32B0_MAT2 — Match output 2 for 32-bit timer 0.
			O	-	USB_FTOGGLE — USB 1 ms Start-of-Frame signal (LPC1342/43 only).
PIO0_2/SSEL0/ CT16B0_CAP0	8 [3]	yes	I/O	I; PU	PIO0_2 — General purpose digital input/output pin.
			I/O	-	SSEL0 — Slave select for SSP0.
			I	-	CT16B0_CAP0 — Capture input 0 for 16-bit timer 0.
PIO0_3/ USB_VBUS	9 [3]	yes	I/O	I; PU	PIO0_3 — General purpose digital input/output pin. LPC1342/43 only: A LOW level on this pin during reset starts the ISP command handler, a HIGH level starts the USB device enumeration.
			I	-	USB_VBUS — Monitors the presence of USB bus power (LPC1342/43 only).
PIO0_4/SCL	10 [4]	yes	I/O	I; IA	PIO0_4 — General purpose digital input/output pin (open-drain).
			I/O	-	SCL — I ² C-bus clock input/output (open-drain). High-current sink only if I ² C Fast-mode Plus is selected in the I/O configuration register.
PIO0_5/SDA	11 [4]	yes	I/O	I; IA	PIO0_5 — General purpose digital input/output pin (open-drain).
			I/O	-	SDA — I ² C-bus data input/output (open-drain). High-current sink only if I ² C Fast-mode Plus is selected in the I/O configuration register.
PIO0_6/ USB_CONNECT/ SCK0	15 [3]	yes	I/O	I; PU	PIO0_6 — General purpose digital input/output pin.
			O	-	USB_CONNECT — Signal used to switch an external 1.5 kΩ resistor under software control. Used with the SoftConnect USB feature (LPC1342/43 only).
			I/O	-	SCK0 — Serial clock for SSP0.
PIO0_7/CTS	16 [3]	yes	I/O	I; PU	PIO0_7 — General purpose digital input/output pin (high-current output driver).
			I	-	CTS — Clear To Send input for UART.
PIO0_8/MISO0/ CT16B0_MAT0	17 [3]	yes	I/O	I; PU	PIO0_8 — General purpose digital input/output pin.
			I/O	-	MISO0 — Master In Slave Out for SSP0.
			O	-	CT16B0_MAT0 — Match output 0 for 16-bit timer 0.
PIO0_9/MOSI0/ CT16B0_MAT1/ SWO	18 [3]	yes	I/O	I; PU	PIO0_9 — General purpose digital input/output pin.
			I/O	-	MOSI0 — Master Out Slave In for SSP0.
			O	-	CT16B0_MAT1 — Match output 1 for 16-bit timer 0.
			O	-	SWO — Serial wire trace output.

Table 4. LPC1311/13/42/43 HVQFN33 pin description table ...continued

Symbol	Pin	Start logic input	Type	Reset state [1]	Description
SWCLK/PIO0_10/ SCK0/ CT16B0_MAT2	19 [3]	yes	I	I; PU	SWCLK — Serial wire clock.
			I/O	-	PIO0_10 — General purpose digital input/output pin.
			I/O	-	SCK0 — Serial clock for SSP0.
			O	-	CT16B0_MAT2 — Match output 2 for 16-bit timer 0.
R/PIO0_11/AD0/ CT32B0_MAT3	21 [5]	yes	-	I; PU	R — Reserved. Configure for an alternate function in the IOCONFIG block.
			I/O	-	PIO0_11 — General purpose digital input/output pin.
			I	-	AD0 — A/D converter, input 0.
			O	-	CT32B0_MAT3 — Match output 3 for 32-bit timer 0.
R/PIO1_0/AD1/ CT32B1_CAP0	22 [5]	yes	-	I; PU	R — Reserved. Configure for an alternate function in the IOCONFIG block.
			I/O	-	PIO1_0 — General purpose digital input/output pin.
			I	-	AD1 — A/D converter, input 1.
			I	-	CT32B1_CAP0 — Capture input 0 for 32-bit timer 1.
R/PIO1_1/AD2/ CT32B1_MAT0	23 [5]	yes	-	I; PU	R — Reserved. Configure for an alternate function in the IOCONFIG block.
			I/O	-	PIO1_1 — General purpose digital input/output pin.
			I	-	AD2 — A/D converter, input 2.
			O	-	CT32B1_MAT0 — Match output 0 for 32-bit timer 1.
R/PIO1_2/AD3/ CT32B1_MAT1	24 [5]	yes	-	I; PU	R — Reserved. Configure for an alternate function in the IOCONFIG block.
			I/O	-	PIO1_2 — General purpose digital input/output pin.
			I	-	AD3 — A/D converter, input 3.
			O	-	CT32B1_MAT1 — Match output 1 for 32-bit timer 1.
SWDIO/PIO1_3/ AD4/ CT32B1_MAT2	25 [5]	yes	I/O	I; PU	SWDIO — Serial wire debug input/output.
			I/O	-	PIO1_3 — General purpose digital input/output pin.
			I	-	AD4 — A/D converter, input 4.
			O	-	CT32B1_MAT2 — Match output 2 for 32-bit timer 1.
PIO1_4/AD5/ CT32B1_MAT3/ WAKEUP	26 [5]	yes	I/O	I; PU	PIO1_4 — General purpose digital input/output pin.
			I	-	AD5 — A/D converter, input 5.
			O	-	CT32B1_MAT3 — Match output 3 for 32-bit timer 1.
			I	-	WAKEUP — Deep power-down mode wake-up pin with 20 ns glitch filter. This pin must be pulled HIGH externally to enter Deep power-down mode and pulled LOW to exit Deep power-down mode. A LOW-going pulse as short as 50 ns wakes up the part.
PIO1_5/RTS/ CT32B0_CAP0	30 [3]	yes	I/O	I; PU	PIO1_5 — General purpose digital input/output pin.
			O	-	RTS — Request To Send output for UART.
			I	-	CT32B0_CAP0 — Capture input 0 for 32-bit timer 0.
PIO1_6/RXD/ CT32B0_MAT0	31 [3]	yes	I/O	I; PU	PIO1_6 — General purpose digital input/output pin.
			I	-	RXD — Receiver input for UART.
			O	-	CT32B0_MAT0 — Match output 0 for 32-bit timer 0.

Table 4. LPC1311/13/42/43 HVQFN33 pin description table ...continued

Symbol	Pin	Start logic input	Type	Reset state [1]	Description
PIO1_7/TXD/ CT32B0_MAT1	32 [3]	yes	I/O	I; PU	PIO1_7 — General purpose digital input/output pin.
			O	-	TXD — Transmitter output for UART.
			O	-	CT32B0_MAT1 — Match output 1 for 32-bit timer 0.
PIO1_8/ CT16B1_CAP0	7 [3]	yes	I/O	I; PU	PIO1_8 — General purpose digital input/output pin.
			I	-	CT16B1_CAP0 — Capture input 0 for 16-bit timer 1.
PIO1_9/ CT16B1_MAT0	12 [3]	yes	I/O	I; PU	PIO1_9 — General purpose digital input/output pin.
			O	-	CT16B1_MAT0 — Match output 0 for 16-bit timer 1.
PIO1_10/AD6/ CT16B1_MAT1	20 [5]	yes	I/O	I; PU	PIO1_10 — General purpose digital input/output pin.
			I	-	AD6 — A/D converter, input 6.
			O	-	CT16B1_MAT1 — Match output 1 for 16-bit timer 1.
PIO1_11/AD7	27 [5]	yes	I/O	I; PU	PIO1_11 — General purpose digital input/output pin.
			I	-	AD7 — A/D converter, input 7.
PIO2_0/ $\overline{\text{DTR}}$	1 [3]	yes	I/O	I; PU	PIO2_0 — General purpose digital input/output pin.
			O	-	DTR — Data Terminal Ready output for UART.
PIO3_2	28 [3]	yes	I/O	I; PU	PIO3_2 — General purpose digital input/output pin.
PIO3_4	13 [3]	no	I/O	I; PU	PIO3_4 — General purpose digital input/output pin (LPC1311/13 only).
PIO3_5	14 [3]	no	I/O	I; PU	PIO3_5 — General purpose digital input/output pin (LPC1311/13 only).
USB_DM	13 [6]	no	I/O	F	USB_DM — USB bidirectional D– line (LPC1342/43 only).
USB_DP	14 [6]	no	I/O	F	USB_DP — USB bidirectional D+ line (LPC1342/43 only).
V _{DD}	6; 29	-	I	-	3.3 V supply voltage to the internal regulator, the external rail, and the ADC. Also used as the ADC reference voltage.
XTALIN	4 [7]	-	I	-	Input to the oscillator circuit and internal clock generator circuits. Input voltage must not exceed 1.8 V.
XTALOUT	5 [7]	-	O	-	Output from the oscillator amplifier.
V _{SS}	33	-	-	-	Thermal pad. Connect to ground.

[1] Pin state at reset for default function: I = Input; O = Output; PU = internal pull-up enabled (for V_{DD} = 3.3 V, pin is pulled up to 2.6 V for parts LPC1311/13/42/43 and pulled up to 3.3 V for parts LPC1311/01 and LPC1313/01); IA = inactive, no pull-up/down enabled. F = floating; floating pins, if not used, should be tied to ground or power to minimize power consumption.

[2] 5 V tolerant pad. See [Figure 37](#) for pad characteristics. $\overline{\text{RESET}}$ functionality is not available in Deep power-down mode. Use the WAKEUP pin to reset the chip and wake up from Deep power-down mode. An external pull-up resistor is required on this pin for the Deep power-down mode.

[3] 5 V tolerant pad providing digital I/O functions with configurable pull-up/pull-down resistors and configurable hysteresis (see [Figure 36](#)).

[4] I²C-bus pads compliant with the I²C-bus specification for I²C standard mode and I²C Fast-mode Plus.

[5] 5 V tolerant pad providing digital I/O functions with configurable pull-up/pull-down resistors, configurable hysteresis, and analog input. When configured as a ADC input, digital section of the pad is disabled, and the pin is not 5 V tolerant (see [Figure 36](#)).

[6] Pad provides USB functions. It is designed in accordance with the USB specification, revision 2.0 (Full-speed and Low-speed mode only). This pad is not 5 V tolerant.

[7] When the system oscillator is not used, connect XTALIN and XTALOUT as follows: XTALIN can be left floating or can be grounded (grounding is preferred to reduce susceptibility to noise). XTALOUT should be left floating.

7. Functional description

7.1 Architectural overview

The ARM Cortex-M3 includes three AHB-Lite buses: the system bus, the I-code bus, and the D-code bus (see [Figure 1](#)). The I-code and D-code core buses are faster than the system bus and are used similarly to TCM interfaces: one bus dedicated for instruction fetch (I-code) and one bus for data access (D-code). The use of two core buses allows for simultaneous operations if concurrent operations target different devices.

7.2 ARM Cortex-M3 processor

The ARM Cortex-M3 is a general purpose, 32-bit microprocessor, which offers high performance and very low power consumption. The ARM Cortex-M3 offers many new features, including a Thumb-2 instruction set, low interrupt latency, hardware multiply and divide, interruptible/continuable multiple load and store instructions, automatic state save and restore for interrupts, tightly integrated interrupt controller, and multiple core buses capable of simultaneous accesses.

Pipeline techniques are employed so that all parts of the processing and memory systems can operate continuously. Typically, while one instruction is being executed, its successor is being decoded, and a third instruction is being fetched from memory.

The ARM Cortex-M3 processor is described in detail in the *Cortex-M3 Technical Reference Manual* which is available on the official ARM website.

7.3 On-chip flash program memory

The LPC1311/13/42/43 contain 32 kB (LPC1313 and LPC1343), 16 kB (LPC1342), or 8 kB (LPC1311) of on-chip flash memory.

7.4 On-chip SRAM

The LPC1311/13/42/43 contain a total of 8 kB (LPC1343 and LPC1313) or 4 kB (LPC1342 and LPC1311) on-chip static RAM memory.

7.5 Memory map

The LPC1311/13/42/43 incorporate several distinct memory regions. [Figure 6](#) shows the overall map of the entire address space from the user program viewpoint following reset. The interrupt vector area supports address remapping.

The AHB peripheral area is 2 MB in size and is divided to allow for up to 128 peripherals. The APB peripheral area is 512 kB in size and is divided to allow for up to 32 peripherals. Each peripheral of either type is allocated 16 kB of space. This allows simplifying the address decoding for each peripheral.

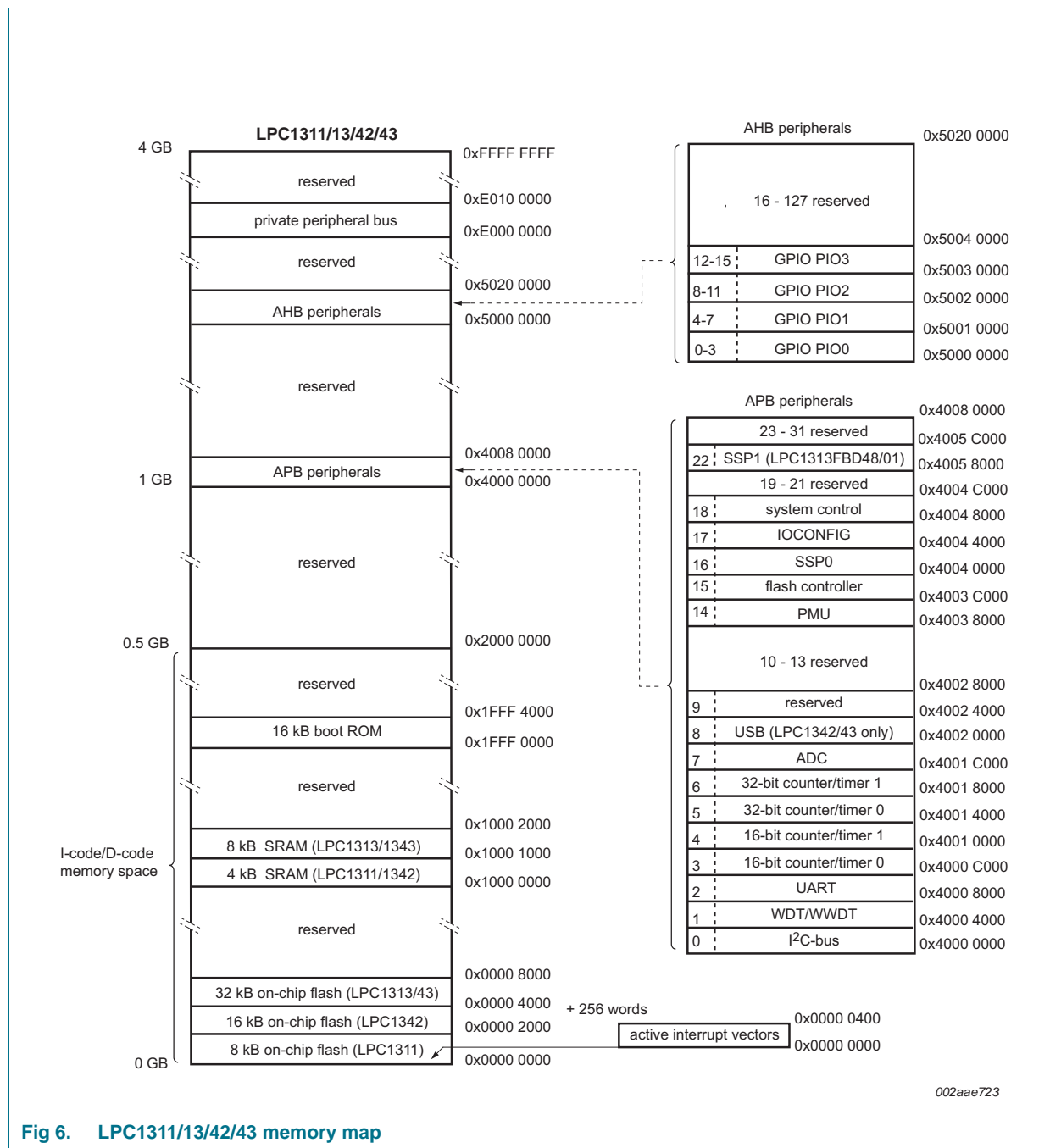

Fig 6. LPC1311/13/42/43 memory map

7.6 Nested Vectored Interrupt Controller (NVIC)

The Nested Vectored Interrupt Controller (NVIC) is an integral part of the Cortex-M3. The tight coupling to the CPU allows for low interrupt latency and efficient processing of late arriving interrupts.

7.6.1 Features

- Controls system exceptions and peripheral interrupts.
- On the LPC1311/13/42/43, the NVIC supports up to 17 vectored interrupts. In addition, up to 40 of the individual GPIO inputs are NVIC-vector capable.
- 8 programmable interrupt priority levels, with hardware priority level masking
- Relocatable vector table.
- Software interrupt generation.

7.6.2 Interrupt sources

Each peripheral device has one interrupt line connected to the NVIC but may have several interrupt flags. Individual interrupt flags may also represent more than one interrupt source.

Any GPIO pin (total of up to 42 pins) regardless of the selected function, can be programmed to generate an interrupt on a level, or rising edge or falling edge, or both.

7.7 IOCONFIG block

The IOCONFIG block allows selected pins of the microcontroller to have more than one function. Configuration registers control the multiplexers to allow connection between the pin and the on-chip peripherals.

Peripherals should be connected to the appropriate pins prior to being activated and prior to any related interrupt(s) being enabled. Activity of any enabled peripheral function that is not mapped to a related pin should be considered undefined.

7.8 Fast general purpose parallel I/O

Device pins that are not connected to a specific peripheral function are controlled by the GPIO registers. Pins may be dynamically configured as inputs or outputs. Multiple outputs can be set or cleared in one write operation.

LPC1311/13/42/43 use accelerated GPIO functions:

- GPIO block is a dedicated AHB peripheral so that the fastest possible I/O timing can be achieved.
- Entire port value can be written in one instruction.

Additionally, any GPIO pin (total of up to 42 pins) providing a digital function can be programmed to generate an interrupt on a level, a rising or falling edge, or both.

7.8.1 Features

- Bit level port registers allow a single instruction to set or clear any number of bits in one write operation.
- Direction control of individual bits.
- All I/O default to inputs with pull-up resistors enabled after reset with the exception of the I²C-bus pins PIO0_4 and PIO0_5.
- Pull-up/pull-down resistor configuration can be programmed through the IOCONFIG block for each GPIO pin.

- On the LPC1311/13/42/43, all GPIO pins (except PIO0_4 and PIO0_5) are pulled up to 2.6 V ($V_{DD} = 3.3$ V) if their pull-up resistor is enabled in the IOCONFIG block.
- On the LPC1311/01 and LPC1313/01, all GPIO pins (except PIO0_4 and PIO0_5) are pulled up to 3.3 V ($V_{DD} = 3.3$ V) if their pull-up resistor is enabled in the IOCONFIG block.

7.9 USB interface (LPC1342/43 only)

The Universal Serial Bus (USB) is a 4-wire bus that supports communication between a host and one or more (up to 127) peripherals. The host controller allocates the USB bandwidth to attached devices through a token-based protocol. The bus supports hot-plugging and dynamic configuration of the devices. All transactions are initiated by the host controller.

The LPC1342/43 USB interface is a device controller with on-chip PHY for device functions.

7.9.1 Full-speed USB device controller

The device controller enables 12 Mbit/s data exchange with a USB Host controller. It consists of a register interface, serial interface engine, and endpoint buffer memory. The serial interface engine decodes the USB data stream and writes data to the appropriate endpoint buffer. The status of a completed USB transfer or error condition is indicated via status registers. An interrupt is also generated if enabled.

7.9.1.1 Features

- Dedicated USB PLL available.
- Fully compliant with *USB 2.0 specification (full speed)*.
- Supports 10 physical (5 logical) endpoints with up to 64 bytes buffer RAM per endpoint (see [Table 5](#)).
- Supports Control, Bulk, Isochronous, and Interrupt endpoints.
- Supports SoftConnect feature.
- Double buffer implementation for Bulk and Isochronous endpoints.

Table 5. USB device endpoint configuration

Logical endpoint	Physical endpoint	Endpoint type	Direction	Packet size (byte)	Double buffer
0	0	Control	out	64	no
0	1	Control	in	64	no
1	2	Interrupt/Bulk	out	64	no
1	3	Interrupt/Bulk	in	64	no
2	4	Interrupt/Bulk	out	64	no
2	5	Interrupt/Bulk	in	64	no
3	6	Interrupt/Bulk	out	64	yes
3	7	Interrupt/Bulk	in	64	yes
4	8	Isochronous	out	512	yes
4	9	Isochronous	in	512	yes

7.10 UART

The LPC1311/13/42/43 contains one UART.

Support for RS-485/9-bit mode allows both software address detection and automatic address detection using 9-bit mode.

The UART includes a fractional baud rate generator. Standard baud rates such as 115200 Bd can be achieved with any crystal frequency above 2 MHz.

7.10.1 Features

- Maximum UART data bit rate of 4.5 MBit/s.
- 16-byte receive and transmit FIFOs.
- Register locations conform to 16C550 industry standard.
- Receiver FIFO trigger points at 1 B, 4 B, 8 B, and 14 B.
- Built-in fractional baud rate generator covering wide range of baud rates without a need for external crystals of particular values.
- Fractional divider for baud rate control, auto baud capabilities and FIFO control mechanism that enables software flow control implementation.
- Support for RS-485/9-bit mode.
- Support for modem control.

7.11 SSP serial I/O controller

The LPC1311/13/42/43 contain one SSP controller. An additional SSP controller is available on the LPC1313FBD48/01 package.

The SSP controller is capable of operation on a SSP, 4-wire SSI, or Microwire bus. It can interact with multiple masters and slaves on the bus. Only a single master and a single slave can communicate on the bus during a given data transfer. The SSP supports full duplex transfers, with frames of 4 bits to 16 bits of data flowing from the master to the slave and from the slave to the master. In practice, often only one of these data flows carries meaningful data.

7.11.1 Features

- Maximum SSP speed of 36 Mbit/s (master) or 6 Mbit/s (slave)
- Compatible with Motorola SPI, 4-wire Texas Instruments SSI, and National Semiconductor Microwire buses
- Synchronous serial communication
- Master or slave operation
- 8-frame FIFOs for both transmit and receive
- 4-bit to 16-bit frame

7.12 I²C-bus serial I/O controller

The LPC1311/13/42/43 contain one I²C-bus controller.

The I²C-bus is bidirectional for inter-IC control using only two wires: a Serial Clock Line (SCL) and a Serial DATA line (SDA). Each device is recognized by a unique address and can operate as either a receiver-only device (e.g., an LCD driver) or a transmitter with the capability to both receive and send information (such as memory). Transmitters and/or receivers can operate in either master or slave mode, depending on whether the chip has to initiate a data transfer or is only addressed. The I²C is a multi-master bus and can be controlled by more than one bus master connected to it.

7.12.1 Features

- The I²C-bus interface is a standard I²C-bus compliant interface with true open-drain pins. The I²C-bus interface also supports Fast-mode Plus with bit rates up to 1 Mbit/s.
- Easy to configure as master, slave, or master/slave.
- Programmable clocks allow versatile rate control.
- Bidirectional data transfer between masters and slaves.
- Multi-master bus (no central master).
- Arbitration between simultaneously transmitting masters without corruption of serial data on the bus.
- Serial clock synchronization allows devices with different bit rates to communicate via one serial bus.
- Serial clock synchronization can be used as a handshake mechanism to suspend and resume serial transfer.
- The I²C-bus can be used for test and diagnostic purposes.
- The I²C-bus controller supports multiple address recognition and a bus monitor mode.

7.13 10-bit ADC

The LPC1311/13/42/43 contains one ADC. It is a single 10-bit successive approximation ADC with eight channels.

7.13.1 Features

- 10-bit successive approximation ADC.
- Input multiplexing among 8 pins.
- Power-down mode.
- Measurement range 0 V to V_{DD}.
- 10-bit conversion time $\geq 2.44 \mu\text{s}$ (up to 400 kSamples/s).
- Burst conversion mode for single or multiple inputs.
- Optional conversion on transition of input pin or timer match signal.
- Individual result registers for each ADC channel to reduce interrupt overhead.

7.14 General purpose external event counter/timers

The LPC1311/13/42/43 includes two 32-bit counter/timers and two 16-bit counter/timers. The counter/timer is designed to count cycles of the system derived clock. It can optionally generate interrupts or perform other actions at specified timer values, based on four match registers. Each counter/timer also includes one capture input to trap the timer value when an input signal transitions, optionally generating an interrupt.

7.14.1 Features

- A 32-bit/16-bit counter/timer with a programmable 32-bit/16-bit prescaler.
- Counter or timer operation.
- One capture channel per timer, that can take a snapshot of the timer value when an input signal transitions. A capture event may also generate an interrupt.
- Four match registers per timer that allow:
 - Continuous operation with optional interrupt generation on match.
 - Stop timer on match with optional interrupt generation.
 - Reset timer on match with optional interrupt generation.
- Up to four external outputs corresponding to match registers, with the following capabilities:
 - Set LOW on match.
 - Set HIGH on match.
 - Toggle on match.
 - Do nothing on match.

7.15 System tick timer

The ARM Cortex-M3 includes a system tick timer (SYSTICK) that is intended to generate a dedicated SYSTICK exception at a fixed time interval, normally set to 10 ms.

7.16 Watchdog timer

Remark: The standard Watchdog timer is available on parts LPC1311/13/42/43.

The purpose of the watchdog is to reset the microcontroller within a selectable time period. When enabled, the watchdog will generate a system reset if the user program fails to 'feed' (or reload) the watchdog within a predetermined amount of time.

7.16.1 Features

- Internally resets chip if not periodically reloaded.
- Debug mode.
- Enabled by software but requires a hardware reset or a watchdog reset/interrupt to be disabled.
- Incorrect/incomplete feed sequence causes reset/interrupt if enabled.
- Flag to indicate watchdog reset.
- Programmable 24-bit timer with internal prescaler.

- Selectable time period from ($T_{cy(WDCLK)} \times 256 \times 4$) to ($T_{cy(WDCLK)} \times 2^{24} \times 4$) in multiples of $T_{cy(WDCLK)} \times 4$.
- The Watchdog Clock (WDCLK) source can be selected from the Internal RC oscillator (IRC), the watchdog oscillator, or the main clock. This gives a wide range of potential timing choices of watchdog operation under different power reduction conditions. It also provides the ability to run the WDT from an entirely internal source that is not dependent on an external crystal and its associated components and wiring for increased reliability.

7.17 Windowed WatchDog Timer (WWDT)

Remark: The windowed watchdog timer is available on parts LPC1311/01 and LPC1313/01.

The purpose of the watchdog is to reset the controller if software fails to periodically service it within a programmable time window.

7.17.1 Features

- Internally resets chip if not periodically reloaded during the programmable time-out period.
- Optional windowed operation requires reload to occur between a minimum and maximum time period, both programmable.
- Optional warning interrupt can be generated at a programmable time prior to watchdog time-out.
- Enabled by software but requires a hardware reset or a watchdog reset/interrupt to be disabled.
- Incorrect feed sequence causes reset or interrupt if enabled.
- Flag to indicate watchdog reset.
- Programmable 24-bit timer with internal prescaler.
- Selectable time period from ($T_{cy(WDCLK)} \times 256 \times 4$) to ($T_{cy(WDCLK)} \times 2^{24} \times 4$) in multiples of $T_{cy(WDCLK)} \times 4$.
- The Watchdog Clock (WDCLK) source can be selected from the IRC or the dedicated watchdog oscillator (WDO). This gives a wide range of potential timing choices of watchdog operation under different power conditions.

7.18 Clocking and power control

7.18.1 Integrated oscillators

The LPC1311/13/42/43 include three independent oscillators. These are the system oscillator, the Internal RC oscillator (IRC), and the watchdog oscillator. Each oscillator can be used for more than one purpose as required in a particular application.

Following reset, the LPC1311/13/42/43 will operate from the internal RC oscillator until switched by software. This allows systems to operate without any external crystal and the bootloader code to operate at a known frequency.

See [Figure 7](#) for an overview of the LPC1311/13/42/43 clock generation.

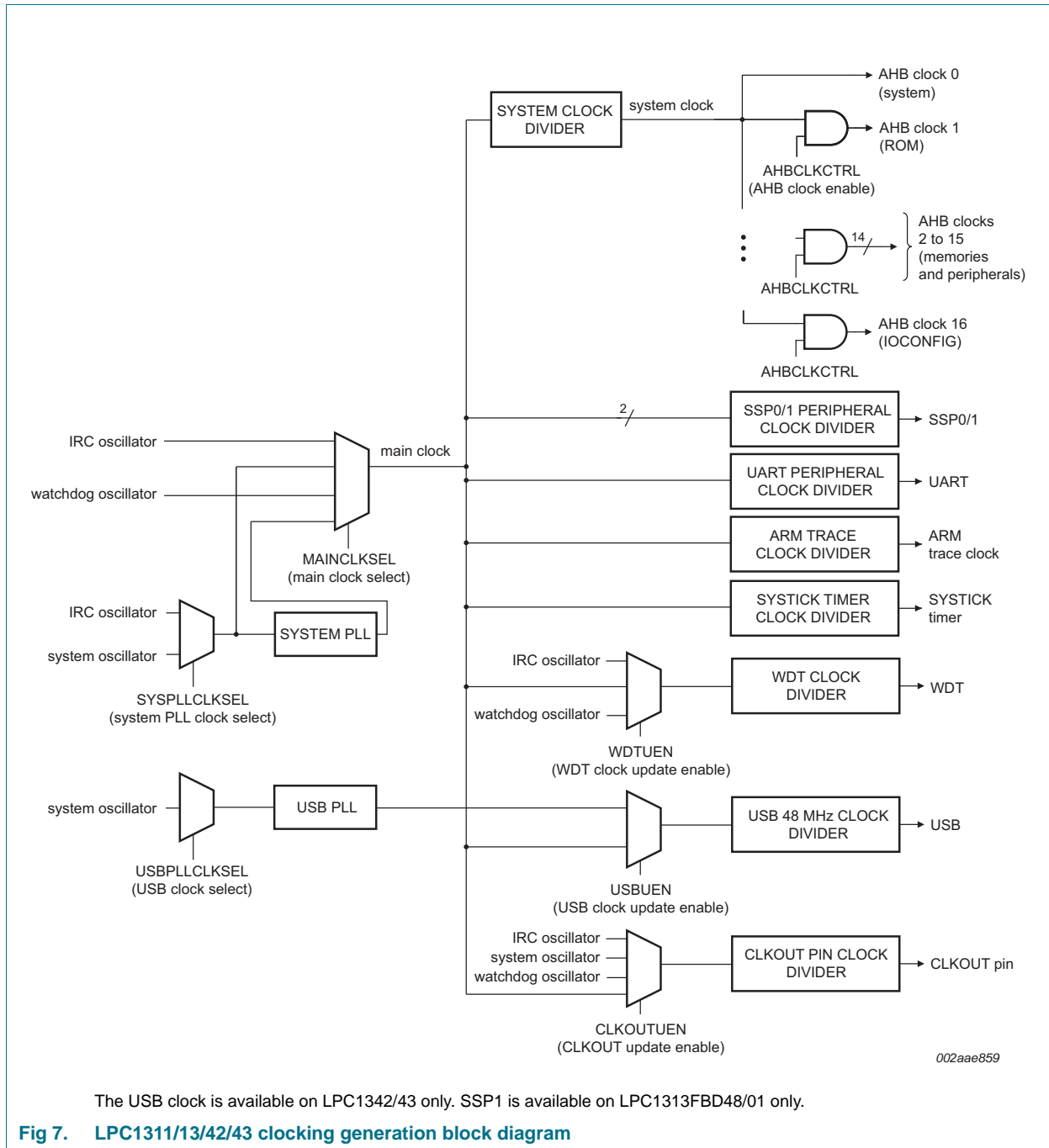

7.18.1.1 Internal RC oscillator

The IRC may be used as the clock source for the WDT, and/or as the clock that drives the system PLL and subsequently the CPU. The nominal IRC frequency is 12 MHz. The IRC is trimmed to 1 % accuracy over the entire voltage and temperature range.

Upon power-up, any chip reset, or wake-up from Deep power-down mode, the LPC1311/13/42/43 use the IRC as the clock source. Software may later switch to one of the other available clock sources.

7.18.1.2 System oscillator

The system oscillator can be used as the clock source for the CPU, with or without using the PLL. On the LPC1342/43, the system oscillator must be used to provide the clock source to USB.

The system oscillator operates at frequencies of 1 MHz to 25 MHz. This frequency can be boosted to a higher frequency, up to the maximum CPU operating frequency, by the system PLL.

7.18.1.3 Watchdog oscillator

The watchdog oscillator can be used as a clock source that directly drives the CPU, the watchdog timer, or the CLKOUT pin. The watchdog oscillator nominal frequency is programmable between 7.8 kHz and 1.7 MHz. The frequency spread over processing and temperature is $\pm 40\%$ (see also [Table 16](#)).

7.18.2 System PLL and USB PLL

The LPC1342/43 contain a system PLL and a dedicated PLL for generating the 48 MHz USB clock. The LPC131x contain the system PLL only. The system and USB PLLs are identical.

The PLL accepts an input clock frequency in the range of 10 MHz to 25 MHz. The input frequency is multiplied up to a high frequency with a Current Controlled Oscillator (CCO). The multiplier can be an integer value from 1 to 32. The CCO operates in the range of 156 MHz to 320 MHz, so there is an additional divider in the loop to keep the CCO within its frequency range while the PLL is providing the desired output frequency. The output divider may be set to divide by 2, 4, 8, or 16 to produce the output clock. The PLL output frequency must be lower than 100 MHz. Since the minimum output divider value is 2, it is insured that the PLL output has a 50 % duty cycle. The PLL is turned off and bypassed following a chip reset and may be enabled by software. The program must configure and activate the PLL, wait for the PLL to lock, and then connect to the PLL as a clock source. The PLL settling time is 100 μ s.

7.18.3 Clock output

The LPC1311/13/42/43 features a clock output function that routes the IRC oscillator, the system oscillator, the watchdog oscillator, or the main clock to an output pin.

7.18.4 Wake-up process

The LPC1311/13/42/43 begin operation at power-up and when awakened from Deep power-down mode by using the 12 MHz IRC oscillator as the clock source. This allows chip operation to resume quickly. If the main oscillator or the PLL is needed by the application, software will need to enable these features and wait for them to stabilize before they are used as a clock source.

7.18.5 Power control

The LPC1311/13/42/43 support a variety of power control features. There are three special modes of processor power reduction: Sleep mode, Deep-sleep mode, and Deep power-down mode. The CPU clock rate may also be controlled as needed by changing clock sources, reconfiguring PLL values, and/or altering the CPU clock divider value. This allows a trade-off of power versus processing speed based on application requirements. In addition, a register is provided for shutting down the clocks to individual on-chip peripherals, allowing fine tuning of power consumption by eliminating all dynamic power use in any peripherals that are not required for the application. Selected peripherals have their own clock divider which provides even better power control.

7.18.5.1 Power profiles (LPC1300L series, LPC1311/01 and LPC1313/01 only)

The power consumption in Active and Sleep modes can be optimized for the application through simple calls to the power profile. The power configuration routine configures the LPC1311/01 and the LPC1313/01 for one of the following power modes:

- Default mode corresponding to power configuration after reset.
- CPU performance mode corresponding to optimized processing capability.
- Efficiency mode corresponding to optimized balance of current consumption and CPU performance.
- Low-current mode corresponding to lowest power consumption.

In addition, the power profile includes routines to select the optimal PLL settings for a given system clock and PLL input clock.

7.18.5.2 Sleep mode

When Sleep mode is entered, the clock to the core is stopped. Resumption from the Sleep mode does not need any special sequence but re-enabling the clock to the ARM core.

In Sleep mode, execution of instructions is suspended until either a reset or interrupt occurs. Peripheral functions continue operation during Sleep mode and may generate interrupts to cause the processor to resume execution. Sleep mode eliminates dynamic power used by the processor itself, memory systems and related controllers, and internal buses.

7.18.5.3 Deep-sleep mode

In Deep-sleep mode, the chip is in Sleep mode, and in addition all analog blocks are shut down. As an exception, the user has the option to keep the watchdog oscillator and the BOD circuit running for self-timed wake-up and BOD protection. Deep-sleep mode allows for additional power savings.

Up to 40 pins total can serve as external wake-up pins to the start logic to wake up the chip from Deep-sleep mode (see [Section 7.19.1](#)).

Unless the watchdog oscillator is selected to run in Deep-sleep mode, the clock source should be switched to IRC before entering Deep-sleep mode, because the IRC can be switched on and off glitch-free.

7.18.5.4 Deep power-down mode

In Deep power-down mode, power is shut off to the entire chip with the exception of the WAKEUP pin. The LPC1311/13/42/43 can wake up from Deep power-down mode via the WAKEUP pin.

A LOW-going pulse as short as 50 ns wakes up the part from Deep power-down mode.

When entering Deep power-down mode, an external pull-up resistor is required on the WAKEUP pin to hold it HIGH. The RESET pin must also be held HIGH to prevent it from floating while in Deep power-down mode.

7.19 System control

7.19.1 Start logic

The start logic connects external pins to corresponding interrupts in the NVIC. Each pin shown in [Table 3](#) and [Table 4](#) as input to the start logic has an individual interrupt in the NVIC interrupt vector table. The start logic pins can serve as external interrupt pins when the chip is running. In addition, an input signal on the start logic pins can wake up the chip from Deep-sleep mode when all clocks are shut down.

The start logic must be configured in the system configuration block and in the NVIC before being used.

7.19.2 Reset

Reset has four sources on the LPC1311/13/42/43: the $\overline{\text{RESET}}$ pin, the Watchdog reset, power-on reset (POR), and the Brown-Out Detection (BOD) circuit. The $\overline{\text{RESET}}$ pin is a Schmitt trigger input pin. Assertion of chip reset by any source, once the operating voltage attains a usable level, starts the IRC and initializes the flash controller.

When the internal reset is removed, the processor begins executing at address 0, which is initially the reset vector mapped from the boot block. At that point, all of the processor and peripheral registers have been initialized to predetermined values.

7.19.3 Brownout detection

The LPC1311/13/42/43 includes four levels for monitoring the voltage on the V_{DD} pin. If this voltage falls below one of the four selected levels, the BOD asserts an interrupt signal to the NVIC. This signal can be enabled for interrupt in the Interrupt Enable Register in the NVIC in order to cause a CPU interrupt; if not, software can monitor the signal by reading a dedicated status register. An additional threshold level can be selected to cause a forced reset of the chip.

7.19.4 Code security (Code Read Protection - CRP)

This feature of the LPC1311/13/42/43 allows user to enable different levels of security in the system so that access to the on-chip flash and use of the Serial Wire Debugger (SWD) and In-System Programming (ISP) can be restricted. When needed, CRP is invoked by programming a specific pattern into a dedicated flash location. In-Application Programming (IAP) commands are not affected by the CRP.

In addition, ISP entry via the PIO0_1 pin can be disabled without enabling CRP (NO_ISP mode). For details see the *LPC13xx user manual*.

There are three levels of Code Read Protection:

1. CRP1 disables access to chip via the SWD and allows partial flash update (excluding flash sector 0) using a limited set of the ISP commands. This mode is useful when CRP is required and flash field updates are needed but all sectors can not be erased.
2. CRP2 disables access to chip via the SWD and only allows full flash erase and update using a reduced set of the ISP commands.
3. Running an application with level CRP3 selected fully disables any access to chip via the SWD pins and the ISP. This mode effectively disables ISP override using PIO0_1 pin, too. It is up to the user's application to provide (if needed) flash update mechanism using IAP calls or call reinvoke ISP command to enable flash update via UART.

CAUTION

If level three Code Read Protection (CRP3) is selected, no future factory testing can be performed on the device.

7.19.5 Boot loader

The boot loader controls initial operation after reset and also provides the means to program the flash memory. This could be initial programming of a blank device, erasure and re-programming of a previously programmed device, or programming of the flash memory by the application program in a running system.

The boot loader code is executed every time the part is reset or powered up. The loader can either execute the ISP command handler or the user application code, or, on the LPC1342/43, it can program the flash image via an attached MSC device through USB (Windows operating system only). A LOW level during reset applied to the PIO0_1 pin is considered as an external hardware request to start the ISP command handler or the USB device enumeration. The state of PIO0_3 determines whether the UART or USB interface will be used (LPC1342/43 only).

7.19.6 APB interface

The APB peripherals are located on one APB bus.

7.19.7 AHB-Lite

The AHB-Lite connects the instruction (I-code) and data (D-code) CPU buses of the ARM Cortex-M3 to the flash memory, the main static RAM, and the boot ROM.

7.19.8 External interrupt inputs

All GPIO pins can be level or edge sensitive interrupt inputs. In addition, start logic inputs serve as external interrupts (see [Section 7.19.1](#)).

7.19.9 Memory mapping control

The Cortex-M3 incorporates a mechanism that allows remapping the interrupt vector table to alternate locations in the memory map. This is controlled via the Vector Table Offset Register contained in the NVIC.

The vector table may be located anywhere within the bottom 1 GB of Cortex-M3 address space. The vector table must be located on a 256 word boundary.

7.20 Emulation and debugging

Debug functions are integrated into the ARM Cortex-M3. Serial wire debug is supported.

8. Limiting values

Table 6. Limiting values

In accordance with the Absolute Maximum Rating System (IEC 60134).^[1]

Symbol	Parameter	Conditions	Min	Max	Unit
V_{DD}	supply voltage (core and external rail)		2.0	3.6	V
V_I	input voltage	5 V tolerant I/O pins; only valid when the V_{DD} supply voltage is present	^[2] -0.5	+5.5	V
I_{DD}	supply current	per supply pin	-	100	mA
I_{SS}	ground current	per ground pin	-	100	mA
I_{latch}	I/O latch-up current	$-(0.5V_{DD}) < V_I < (1.5V_{DD})$; $T_j < 125\text{ }^\circ\text{C}$	-	100	mA
T_{stg}	storage temperature	non-operating	^[3] -65	+150	$^\circ\text{C}$
$T_{j(max)}$	maximum junction temperature		-	150	$^\circ\text{C}$
$P_{tot(pack)}$	total power dissipation (per package)	based on package heat transfer, not device power consumption	-	1.5	W
V_{ESD}	electrostatic discharge voltage	human body model; all pins	^[4] -6500	+6500	V

[1] The following applies to the limiting values:

- a) This product includes circuitry specifically designed for the protection of its internal devices from the damaging effects of excessive static charge. Nonetheless, it is suggested that conventional precautions be taken to avoid applying greater than the rated maximum.
- b) Parameters are valid over operating temperature range unless otherwise specified. All voltages are with respect to V_{SS} unless otherwise noted.

[2] Including voltage on outputs in 3-state mode.

[3] The maximum non-operating storage temperature is different than the temperature for required shelf life which should be determined based on required shelf lifetime. Please refer to the JEDEC specification J-STD-033B.1 for further details.

[4] Human body model: equivalent to discharging a 100 pF capacitor through a 1.5 k Ω series resistor.

9. Static characteristics

Table 7. Static characteristics

$T_{amb} = -40\text{ }^{\circ}\text{C}$ to $+85\text{ }^{\circ}\text{C}$, unless otherwise specified.

Symbol	Parameter	Conditions	Min	Typ ^[1]	Max	Unit
V_{DD}	supply voltage (core and external rail)		^[2] 2.0	3.3	3.6	V

LPC1300 series (LPC1311/13/42/43) power consumption

I_{DD}	supply current	Active mode; $V_{DD} = 3.3\text{ V}$; $T_{amb} = 25\text{ }^{\circ}\text{C}$; code while(1){} executed from flash;					
		system clock = 12 MHz	^[3] ^[4] ^[5] ^[6] ^[7]	-	4	-	mA
		system clock = 72 MHz	^[4] ^[5] ^[6] ^[8] ^[7]	-	17	-	mA
		Sleep mode; $V_{DD} = 3.3\text{ V}$; $T_{amb} = 25\text{ }^{\circ}\text{C}$; system clock = 12 MHz	^[3] ^[4] ^[5] ^[6] ^[7]	-	2	-	mA
		Deep-sleep mode; $V_{DD} = 3.3\text{ V}$; $T_{amb} = 25\text{ }^{\circ}\text{C}$	^[4] ^[9] ^[7]	-	30	-	μA
		Deep power-down mode; $V_{DD} = 3.3\text{ V}$; $T_{amb} = 25\text{ }^{\circ}\text{C}$	^[10]	-	220	-	nA

LPC1300L series (LPC1311/01, LPC1313/01) power consumption in low-current mode^[11]

I_{DD}	supply current	Active mode; $V_{DD} = 3.3\text{ V}$; $T_{amb} = 25\text{ }^{\circ}\text{C}$; code while(1){} executed from flash;					
		system clock = 12 MHz	^[3] ^[4] ^[5] ^[6] ^[7]	-	2	-	mA
		system clock = 72 MHz	^[4] ^[5] ^[6] ^[8] ^[7]	-	13	-	mA
		Sleep mode; $V_{DD} = 3.3\text{ V}$; $T_{amb} = 25\text{ }^{\circ}\text{C}$; system clock = 12 MHz	^[3] ^[4] ^[5] ^[6] ^[7]	-	1	-	mA
		Deep-sleep mode; $V_{DD} = 3.3\text{ V}$; $T_{amb} = 25\text{ }^{\circ}\text{C}$	^[4] ^[9] ^[7]	-	2	-	μA
		Deep power-down mode; $V_{DD} = 3.3\text{ V}$; $T_{amb} = 25\text{ }^{\circ}\text{C}$	^[10]	-	220	-	nA

Standard port pins and RESET pin; see [Figure 21](#), [Figure 22](#), [Figure 23](#), [Figure 24](#)

I_{IL}	LOW-level input current	$V_I = 0\text{ V}$; on-chip pull-up resistor disabled	-	0.5	10	nA	
I_{IH}	HIGH-level input current	$V_I = V_{DD}$; on-chip pull-down resistor disabled	-	0.5	10	nA	
I_{OZ}	OFF-state output current	$V_O = 0\text{ V}$; $V_O = V_{DD}$; on-chip pull-up/down resistors disabled	-	0.5	10	nA	
V_I	input voltage	pin configured to provide a digital function	^[12] ^[13] ^[14]	0	-	5.0	V

Table 7. Static characteristics ...continued
T_{amb} = -40 °C to +85 °C, unless otherwise specified.

Symbol	Parameter	Conditions	Min	Typ ^[1]	Max	Unit
V _O	output voltage	output active	0	-	V _{DD}	V
V _{IH}	HIGH-level input voltage		0.7V _{DD}	-	-	V
V _{IL}	LOW-level input voltage		-	-	0.3V _{DD}	V
V _{hys}	hysteresis voltage		0.4	-	-	V
V _{OH}	HIGH-level output voltage	2.5 V ≤ V _{DD} ≤ 3.6 V; I _{OH} = -4 mA	V _{DD} - 0.4	-	-	V
		2.0 V ≤ V _{DD} < 2.5 V; I _{OH} = -3 mA	V _{DD} - 0.4	-	-	V
V _{OL}	LOW-level output voltage	2.5 V ≤ V _{DD} ≤ 3.6 V; I _{OL} = 4 mA	-	-	0.4	V
		2.0 V ≤ V _{DD} < 2.5 V; I _{OL} = 3 mA	-	-	0.4	V
I _{OH}	HIGH-level output current	2.5 V ≤ V _{DD} ≤ 3.6 V; V _{OH} = V _{DD} - 0.4 V	-4	-	-	mA
		2.0 V ≤ V _{DD} < 2.5 V; V _{OH} = V _{DD} - 0.4 V	-3	-	-	mA
I _{OL}	LOW-level output current	2.5 V ≤ V _{DD} ≤ 3.6 V; V _{OL} = 0.4 V	4	-	-	mA
		2.0 V ≤ V _{DD} < 2.5 V; V _{OL} = 0.4 V	3	-	-	mA
I _{OHS}	HIGH-level short-circuit output current	V _{OH} = 0 V	[15] -	-	-45	mA
I _{OLS}	LOW-level short-circuit output current	V _{OL} = V _{DD}	[15] -	-	50	mA
I _{pd}	pull-down current	V _I = 5 V	10	50	150	μA
I _{pu}	pull-up current	V _I = 0 V	-15	-50	-85	μA
		V _{DD} < V _I < 5 V	0	0	0	μA
High-drive output pin (PIO0_7); see Figure 19 and Figure 21						
I _{IL}	LOW-level input current	V _I = 0 V; on-chip pull-up resistor disabled	-	0.5	10	nA
I _{IH}	HIGH-level input current	V _I = V _{DD} ; on-chip pull-down resistor disabled	-	0.5	10	nA
I _{OZ}	OFF-state output current	V _O = 0 V; V _O = V _{DD} ; on-chip pull-up/down resistors disabled	-	0.5	10	nA
V _I	input voltage	pin configured to provide a digital function	[12][13] [14] 0	-	5.0	V
V _O	output voltage	output active	0	-	V _{DD}	V
V _{IH}	HIGH-level input voltage		0.7V _{DD}	-	-	V
V _{IL}	LOW-level input voltage		-	-	0.3V _{DD}	V
V _{hys}	hysteresis voltage		0.4	-	-	V
V _{OH}	HIGH-level output voltage	2.5 V ≤ V _{DD} ≤ 3.6 V; I _{OH} = -20 mA	V _{DD} - 0.4	-	-	V
		2.0 V ≤ V _{DD} < 2.5 V; I _{OH} = -12 mA	V _{DD} - 0.4	-	-	V
V _{OL}	LOW-level output voltage	2.5 V ≤ V _{DD} ≤ 3.6 V; I _{OL} = 4 mA	-	-	0.4	V
		2.0 V ≤ V _{DD} < 2.5 V; I _{OL} = 3 mA	-	-	0.4	V

Table 7. Static characteristics ...continued $T_{amb} = -40\text{ }^{\circ}\text{C}$ to $+85\text{ }^{\circ}\text{C}$, unless otherwise specified.

Symbol	Parameter	Conditions	Min	Typ ^[1]	Max	Unit
I _{OH}	HIGH-level output current	$2.5\text{ V} \leq V_{DD} \leq 3.6\text{ V}$; $V_{OH} = V_{DD} - 0.4\text{ V}$	20	-	-	mA
		$2.0\text{ V} \leq V_{DD} < 2.5\text{ V}$; $V_{OH} = V_{DD} - 0.4\text{ V}$;	12	-	-	mA
I _{OL}	LOW-level output current	$2.5\text{ V} \leq V_{DD} \leq 3.6\text{ V}$; $V_{OL} = 0.4\text{ V}$	4	-	-	mA
		$2.0\text{ V} \leq V_{DD} < 2.5\text{ V}$; $V_{OL} = 0.4\text{ V}$	3	-	-	mA
I _{pd}	pull-down current	$V_I = 5\text{ V}$	10	50	150	μA
I _{pu}	pull-up current	$V_I = 0\text{ V}$	-15	-50	-85	μA
		$V_{DD} < V_I < 5\text{ V}$	0	0	0	μA
I²C-bus pins (PIO0_4 and PIO0_5); see Figure 20						
V _{IH}	HIGH-level input voltage		$0.7V_{DD}$	-	-	V
V _{IL}	LOW-level input voltage		-	-	$0.3V_{DD}$	V
V _{hys}	hysteresis voltage		-	$0.05V_{DD}$	-	V
I _{OL}	LOW-level output current	$V_{OL} = 0.4\text{ V}$; I ² C-bus pins configured as standard mode pins				
		$2.5\text{ V} \leq V_{DD} \leq 3.6\text{ V}$	3.5	-	-	mA
		$2.0\text{ V} \leq V_{DD} < 2.5\text{ V}$	3.0	-	-	mA
I _{OL}	LOW-level output current	$V_{OL} = 0.4\text{ V}$; I ² C-bus pins configured as Fast-mode Plus pins				
		$2.5\text{ V} \leq V_{DD} \leq 3.6\text{ V}$	20	-	-	mA
		$2.0\text{ V} \leq V_{DD} < 2.5\text{ V}$	16	-	-	
I _{LI}	input leakage current	$V_I = V_{DD}$	^[16] -	2	4	μA
		$V_I = 5\text{ V}$	-	10	22	μA
Oscillator pins						
V _{i(xtal)}	crystal input voltage		-0.5	+1.8	+1.95	V
V _{o(xtal)}	crystal output voltage		-0.5	+1.8	+1.95	V
USB pins (LPC1342/43 only)						
I _{OZ}	OFF-state output current	$0\text{ V} < V_I < 3.3\text{ V}$	^[17] -	-	±10	μA
V _{BUS}	bus supply voltage		^[17] -	-	5.25	V
V _{DI}	differential input sensitivity voltage	$ (D+) - (D-) $	^[17] 0.2	-	-	V
V _{CM}	differential common mode voltage range	includes V _{DI} range	^[17] 0.8	-	2.5	V
V _{th(rs)se}	single-ended receiver switching threshold voltage		^[17] 0.8	-	2.0	V
V _{OL}	LOW-level output voltage	for low-/full-speed; R _L of 1.5 kΩ to 3.6 V	^[17] -	-	0.18	V

Table 7. Static characteristics ...continued $T_{amb} = -40\text{ }^{\circ}\text{C}$ to $+85\text{ }^{\circ}\text{C}$, unless otherwise specified.

Symbol	Parameter	Conditions	Min	Typ ^[1]	Max	Unit
V_{OH}	HIGH-level output voltage	driven; for low-/full-speed; R_L of 15 k Ω to GND	[17] 2.8	-	3.5	V
C_{trans}	transceiver capacitance	pin to GND	[17] -	-	20	pF
Z_{DRV}	driver output impedance for driver which is not high-speed capable	with 33 Ω series resistor; steady state drive	[18][17] 36	-	44.1	Ω

- [1] Typical ratings are not guaranteed. The values listed are at room temperature (25 $^{\circ}\text{C}$), nominal supply voltages.
- [2] For LPC1342 and LPC1343 only: For USB operation $3.0\text{ V} \leq V_{DD} \leq 3.6\text{ V}$. Guaranteed by design.
- [3] IRC enabled; system oscillator disabled; system PLL disabled.
- [4] I_{DD} measurements were performed with all pins configured as GPIO outputs driven LOW and pull-up resistors disabled.
- [5] BOD disabled.
- [6] All peripherals disabled in the SYSAHBCLKCTRL register. Peripheral clocks to UART, SSP, trace clock, and SysTick timer disabled in the syscon block.
- [7] For LPC1342/43: USB_DP and USB_DM pulled LOW externally.
- [8] IRC disabled; system oscillator enabled; system PLL enabled.
- [9] All oscillators and analog blocks turned off in the PDSLEEPCFG register; PDSLEEPCFG = 0x0000 0FFF.
- [10] WAKEUP pin pulled HIGH externally. An external pull-up resistor is required on the $\overline{\text{RESET}}$ pin for the Deep power-down mode.
- [11] Low-current mode PWR_LOW_CURRENT selected when running the set_power routine in the power profiles.
- [12] Including voltage on outputs in 3-state mode.
- [13] V_{DD} supply voltage must be present.
- [14] 3-state outputs go into 3-state mode in Deep power-down mode.
- [15] Allowed as long as the current limit does not exceed the maximum current allowed by the device.
- [16] To V_{SS} .
- [17] $3.0\text{ V} \leq V_{DD} \leq 3.6\text{ V}$.
- [18] Includes external resistors of 33 $\Omega \pm 1\%$ on USB_DP and USB_DM.

Table 8. ADC static characteristics $T_{amb} = -40\text{ }^{\circ}\text{C}$ to $+85\text{ }^{\circ}\text{C}$ unless otherwise specified; ADC frequency 4.5 MHz, $V_{DD} = 2.5\text{ V}$ to 3.6 V.

Symbol	Parameter	Conditions	Min	Typ	Max	Unit
V_{IA}	analog input voltage		0	-	V_{DD}	V
C_{ia}	analog input capacitance		-	-	1	pF
E_D	differential linearity error		[1][2] -	-	± 1	LSB
$E_{L(\text{adj})}$	integral non-linearity		[3] -	-	± 1.5	LSB
E_O	offset error		[4] -	-	± 3.5	LSB
E_G	gain error		[5] -	-	0.6	%
E_T	absolute error		[6] -	-	± 4	LSB
R_{vsi}	voltage source interface resistance		-	-	40	k Ω
R_i	input resistance		[7][8] -	-	2.5	M Ω

- [1] The ADC is monotonic, there are no missing codes.
- [2] The differential linearity error (E_D) is the difference between the actual step width and the ideal step width. See [Figure 8](#).

- [3] The integral non-linearity ($E_{L(\text{adj})}$) is the peak difference between the center of the steps of the actual and the ideal transfer curve after appropriate adjustment of gain and offset errors. See [Figure 8](#).
- [4] The offset error (E_O) is the absolute difference between the straight line which fits the actual curve and the straight line which fits the ideal curve. See [Figure 8](#).
- [5] The gain error (E_G) is the relative difference in percent between the straight line fitting the actual transfer curve after removing offset error, and the straight line which fits the ideal transfer curve. See [Figure 8](#).
- [6] The absolute error (E_T) is the maximum difference between the center of the steps of the actual transfer curve of the non-calibrated ADC and the ideal transfer curve. See [Figure 8](#).
- [7] $T_{\text{amb}} = 25\text{ }^\circ\text{C}$; maximum sampling frequency $f_s = 400\text{ kSamples/s}$ and analog input capacitance $C_{\text{ia}} = 1\text{ pF}$.
- [8] Input resistance R_i depends on the sampling frequency f_s : $R_i = 1 / (f_s \times C_{\text{ia}})$.

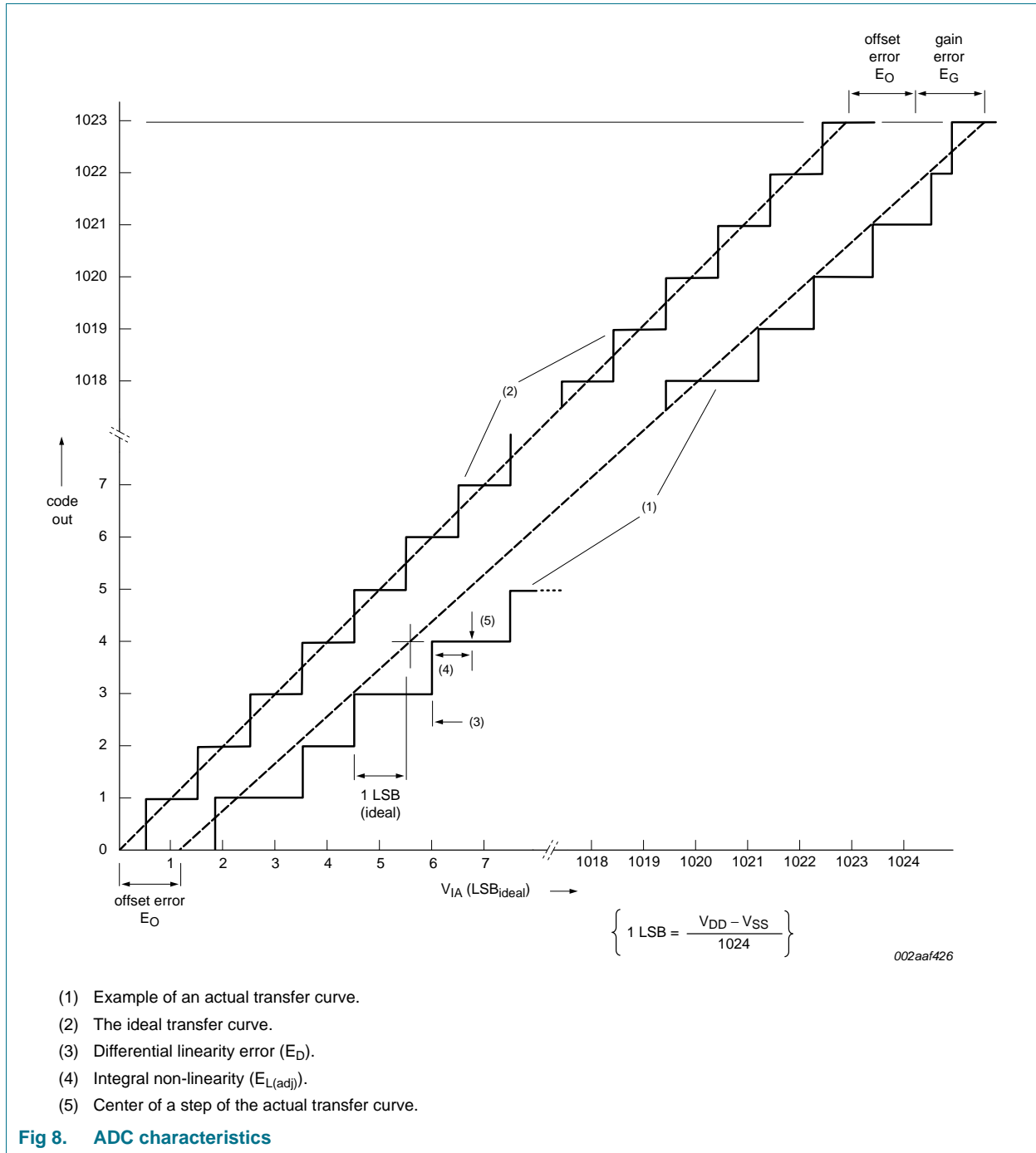

9.1 BOD static characteristics for LPC1300 series

Remark: Applies to parts LPC1311/13/42/43 and all their packages.

Table 9. BOD static characteristics^[1]

$T_{amb} = 25\text{ }^{\circ}\text{C}$.

Symbol	Parameter	Conditions	Min	Typ	Max	Unit
V_{th}	threshold voltage	interrupt level 0				
		assertion	-	1.69	-	V
		de-assertion	-	1.84	-	V
		interrupt level 1				
		assertion	-	2.29	-	V
		de-assertion	-	2.44	-	V
		interrupt level 2				
		assertion	-	2.59	-	V
		de-assertion	-	2.74	-	V
		interrupt level 3				
		assertion	-	2.87	-	V
		de-assertion	-	2.98	-	V
		reset level 0				
		assertion	-	1.49	-	V
		de-assertion	-	1.64	-	V

[1] Interrupt levels are selected by writing the level value to the BOD control register BODCTRL, see *LPC13xx user manual*.

9.2 BOD static characteristics for LPC1300L series (LPC1311/01 and LPC1313/01)

Remark: Applies to parts LPC1311/01 and LPC1313/01 and all packages.

Table 10. BOD static characteristics^[1]

$T_{amb} = 25\text{ }^{\circ}\text{C}$.

Symbol	Parameter	Conditions	Min	Typ	Max	Unit	
V_{th}	threshold voltage	interrupt level 0					
		assertion	-	1.65	-	V	
		de-assertion	-	1.80	-	V	
		interrupt level 1					
		assertion	-	2.22	-	V	
		de-assertion	-	2.35	-	V	
		interrupt level 2					
		assertion	-	2.52	-	V	
		de-assertion	-	2.66	-	V	
		interrupt level 3					
		assertion	-	2.80	-	V	
		de-assertion	-	2.90	-	V	
		reset level 0					
		assertion	-	1.46	-	V	
		de-assertion	-	1.63	-	V	
		reset level 1					
		assertion	-	2.06	-	V	
		de-assertion	-	2.15	-	V	
		reset level 2					
		assertion	-	2.35	-	V	
		de-assertion	-	2.43	-	V	
		reset level 3					
		assertion	-	2.63	-	V	
		de-assertion	-	2.71	-	V	

[1] Interrupt levels are selected by writing the level value to the BOD control register BODCTRL, see *LPC13xx user manual*.

9.3 Power consumption for LPC1300 series

Remark: Applies to parts LPC1311/13/42/43 and all their packages.

Power measurements in Active, Sleep, and Deep-sleep modes were performed under the following conditions (see *LPC13xx user manual*):

- Configure all pins as GPIO with pull-up resistor disabled in the IOCONFIG block.
- Configure GPIO pins as outputs using the GPIODIR registers.
- Write 0 to all GPIODATA registers to drive the outputs LOW.

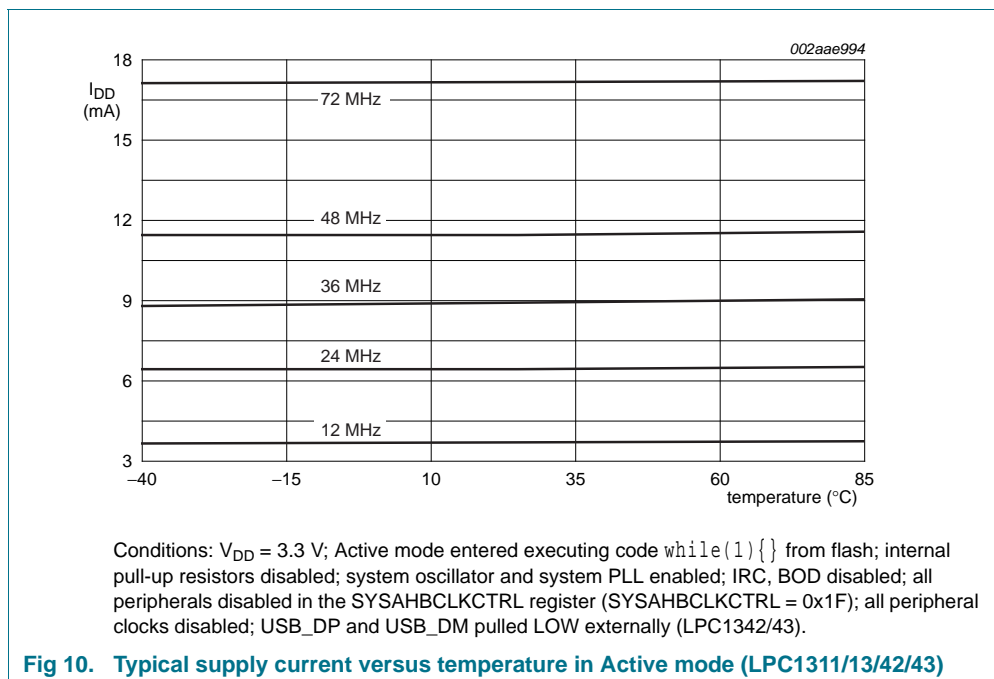
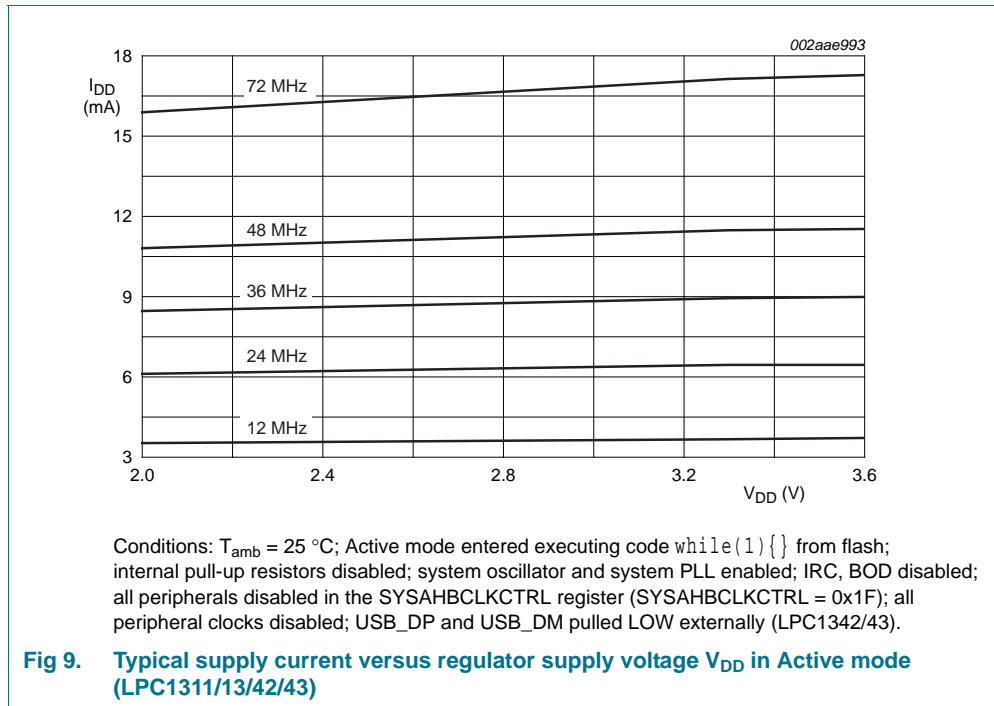

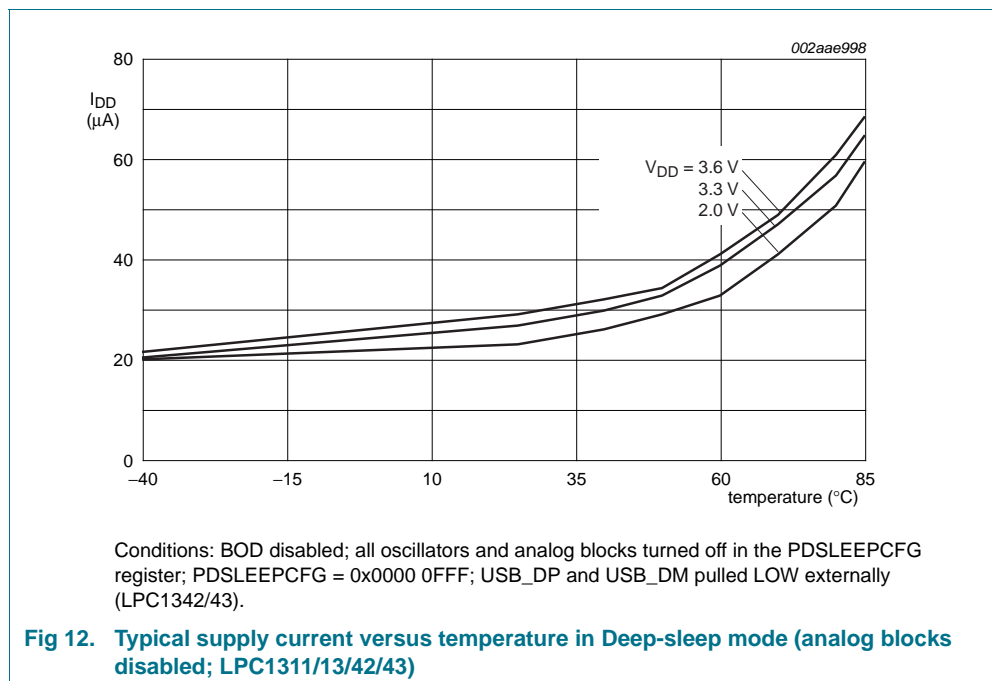
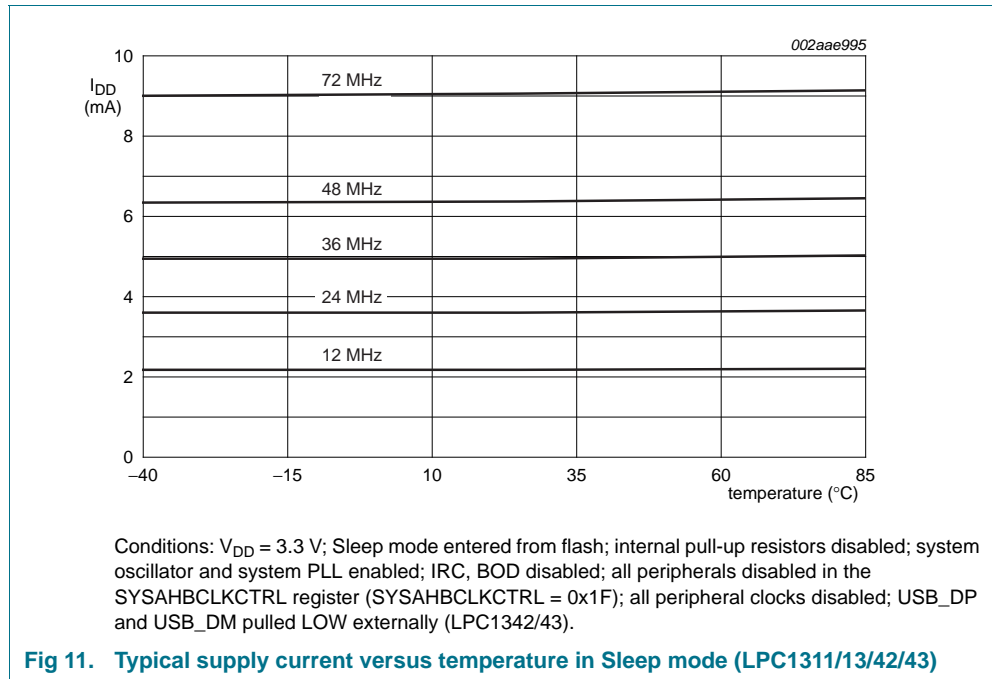

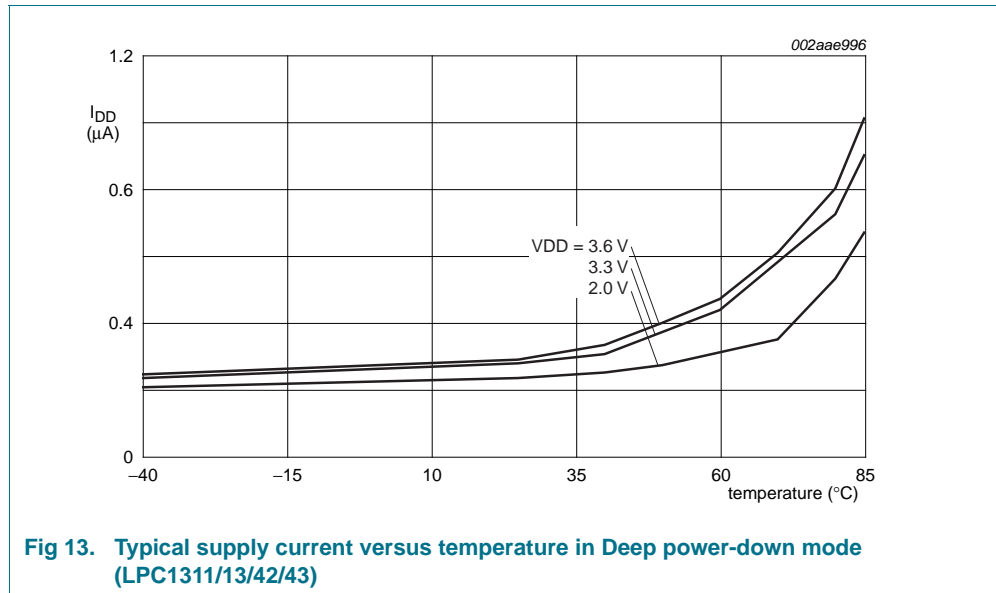

9.4 Power consumption for LPC1300L series (LPC1311/01 and LPC1313/01)

Remark: Applies to parts LPC1311/01 and LPC1313/01 and all their packages.

Power measurements in Active, Sleep, and Deep-sleep modes were performed under the following conditions (see *LPC13xx user manual*):

- Configure all pins as GPIO with pull-up resistor disabled in the IOCONFIG block.
- Configure GPIO pins as outputs using the GPIOnDIR registers.
- Write 0 to all GPIOnDATA registers to drive the outputs LOW.

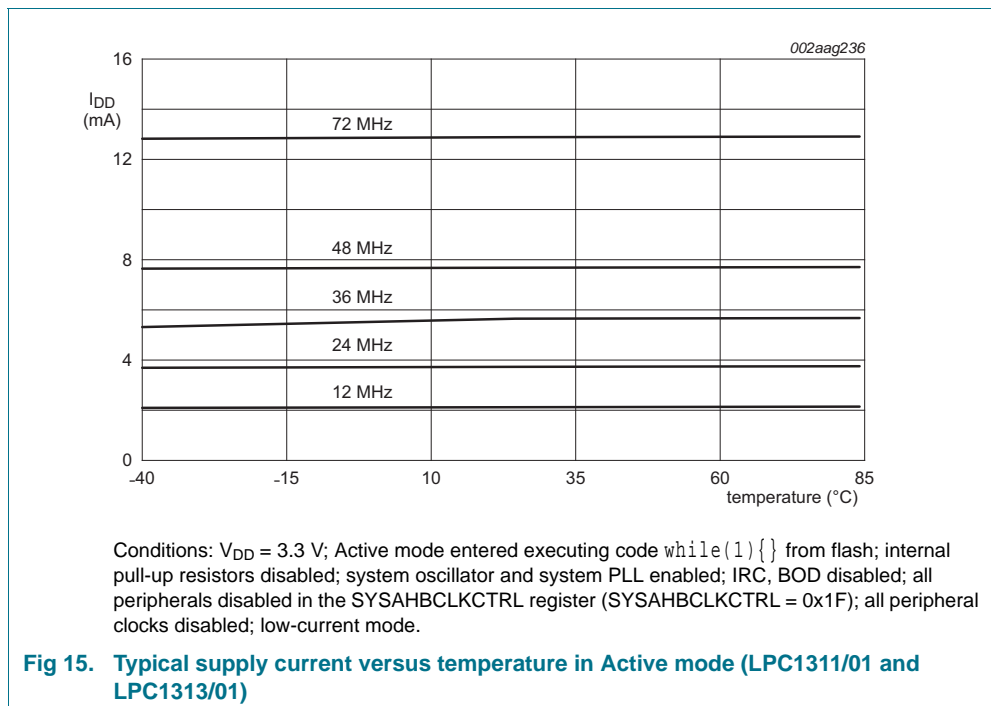
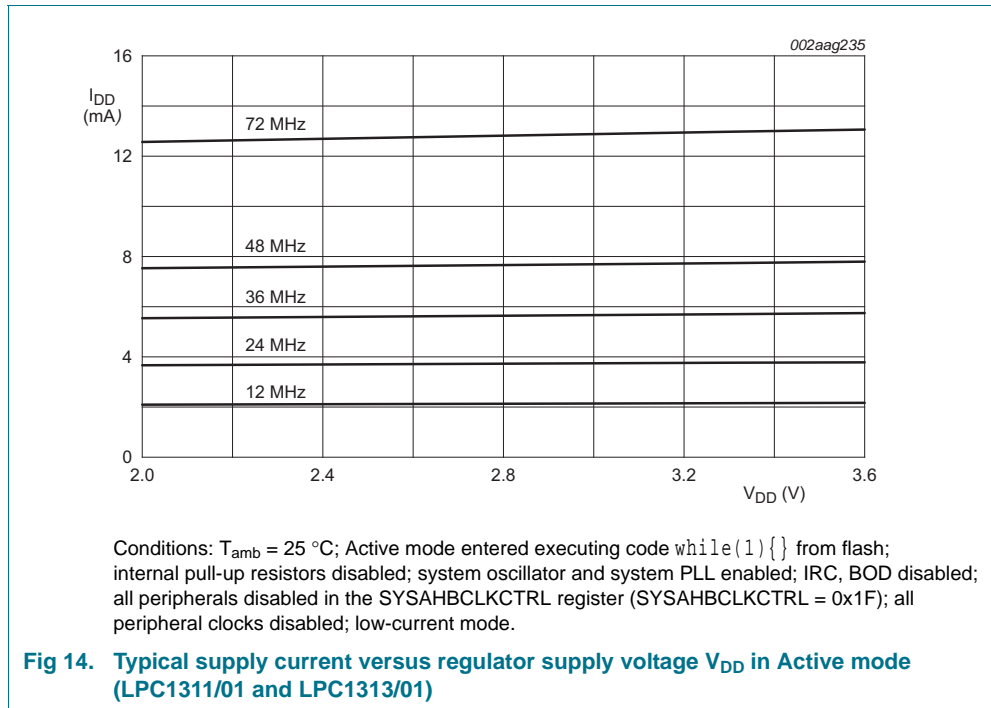

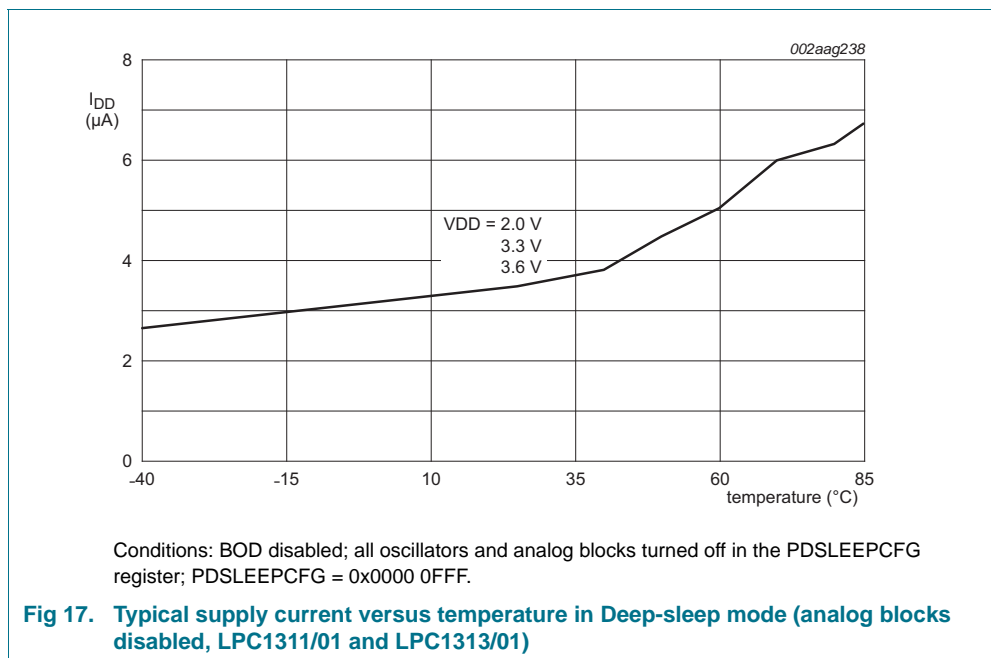
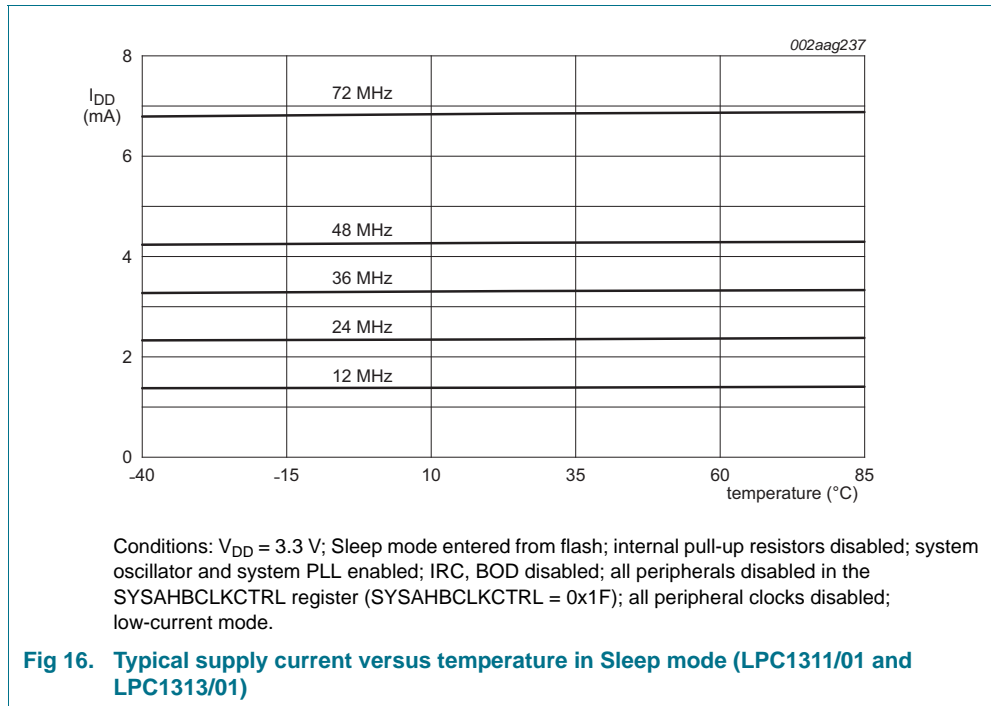

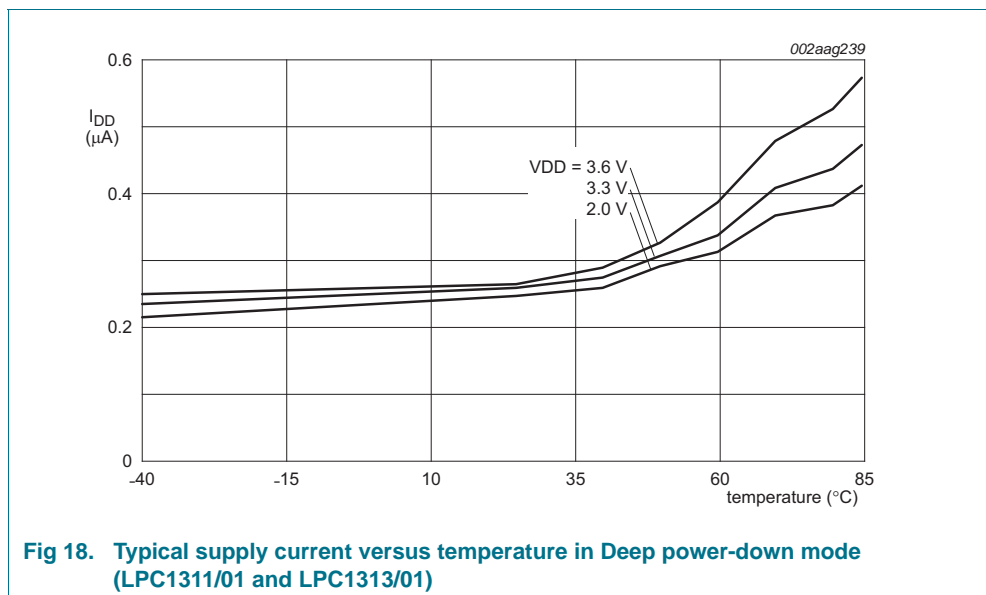

Fig 18. Typical supply current versus temperature in Deep power-down mode (LPC1311/01 and LPC1313/01)

9.5 Peripheral power consumption

The supply current per peripheral is measured as the difference in supply current between the peripheral block enabled and the peripheral block disabled in the SYSAHBCLKCFG or PDRUNCFG (for analog blocks) registers. All other blocks are disabled in both registers and no code is executed. Measured on a typical sample at $T_{amb} = 25\text{ }^{\circ}\text{C}$. Unless noted otherwise, the system oscillator and PLL are running in both measurements.

The supply currents are shown for system clock frequencies of 12 MHz, 48 MHz, and 72 MHz.

Table 11. Power consumption for individual analog and digital blocks

Peripheral	Typical supply current in mA				Notes
	n/a	12 MHz	48 MHz	72 MHz	
IRC	0.23	-	-	-	System oscillator running; PLL off; independent of main clock frequency.
System oscillator at 12 MHz	0.23	-	-	-	IRC running; PLL off; independent of main clock frequency.
Watchdog oscillator at 500 kHz/2	0.002	-	-	-	System oscillator running; PLL off; independent of main clock frequency.
BOD	0.045	-	-	-	Independent of main clock frequency.
Main or USB PLL	-	0.26	0.34	0.48	-
ADC	-	0.07	0.25	0.37	-
CLKOUT	-	0.14	0.56	0.82	Main clock divided by 4 in the CLKOUTDIV register.
CT16B0	-	0.01	0.05	0.08	-
CT16B1	-	0.01	0.04	0.06	-
CT32B0	-	0.01	0.05	0.07	-
CT32B1	-	0.01	0.04	0.06	-

Table 11. Power consumption for individual analog and digital blocks ...continued

Peripheral	Typical supply current in mA				Notes
	n/a	12 MHz	48 MHz	72 MHz	
GPIO	-	0.21	0.80	1.17	GPIO pins configured as outputs and set to LOW. Direction and pin state are maintained if the GPIO is disabled in the SYSAHBCLKCFG register.
IOCONFIG	-	0.00	0.02	0.02	-
I2C	-	0.03	0.12	0.17	-
ROM	-	0.04	0.15	0.22	-
SSP0	-	0.11	0.41	0.60	-
SSP1	-	0.11	0.41	0.60	On LPC1313FBD48/01 only.
UART	-	0.20	0.76	1.11	-
WDT	-	0.01	0.05	0.08	Main clock selected as clock source for the WDT.
USB	-	-	3.91	-	Main clock selected as clock source for the USB. USB_DP and USB_DM pulled LOW externally.
USB	-	1.84	4.19	5.71	Dedicated USB PLL selected as clock source for the USB. USB_DP and USB_DM pulled LOW externally.

9.6 Electrical pin characteristics

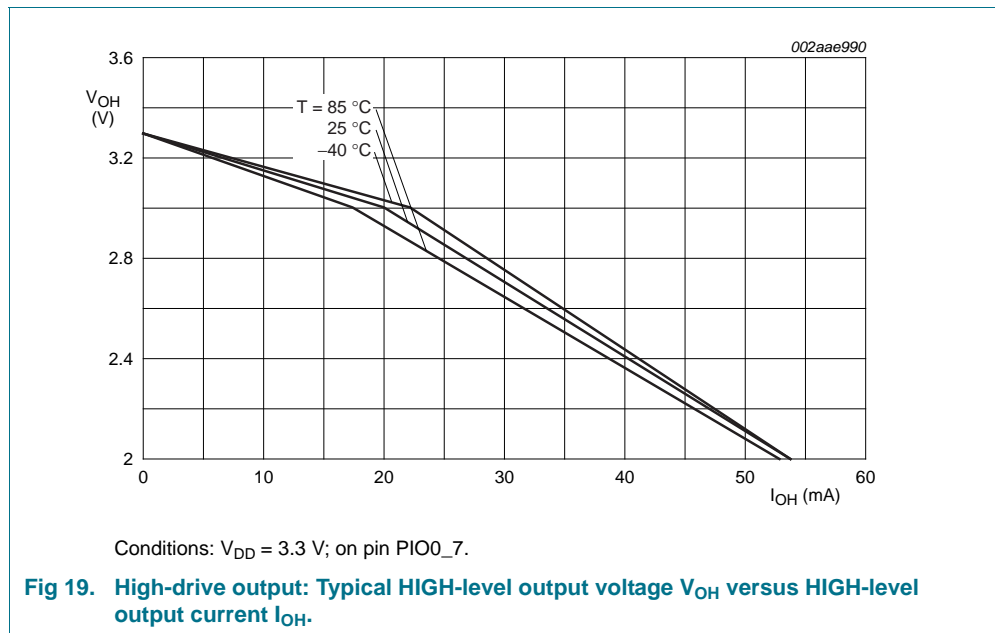

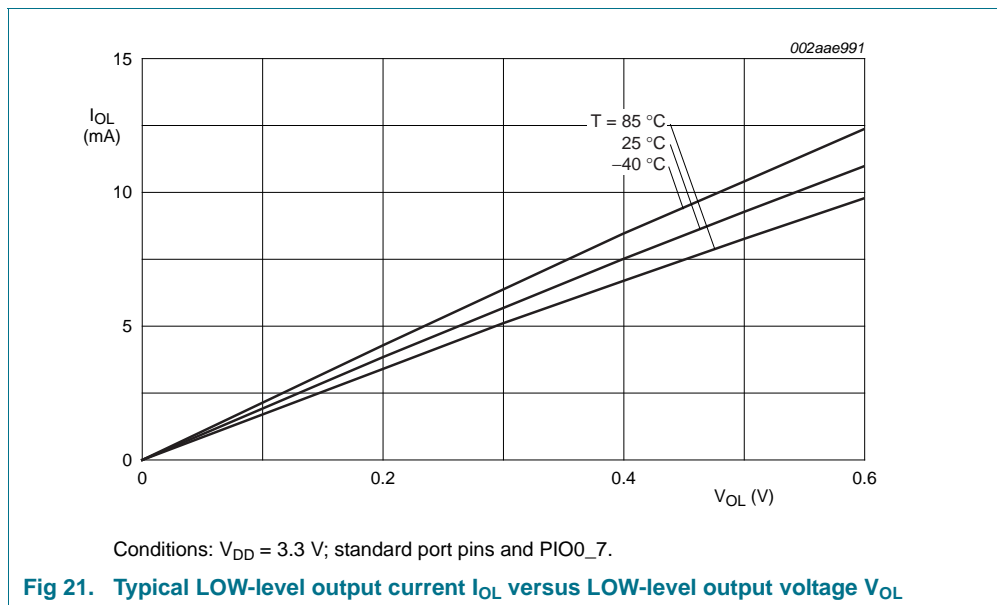
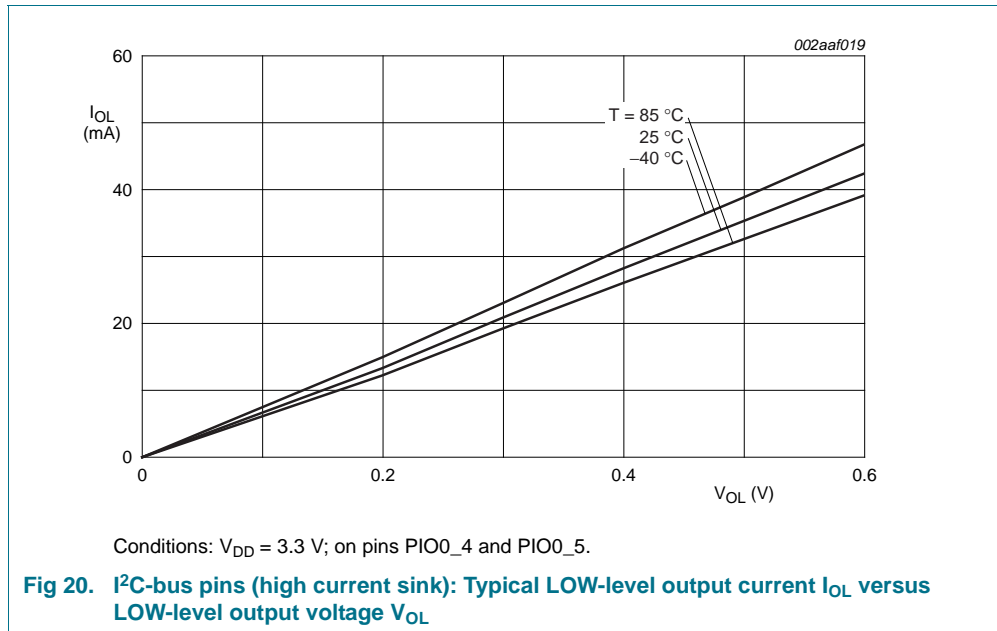

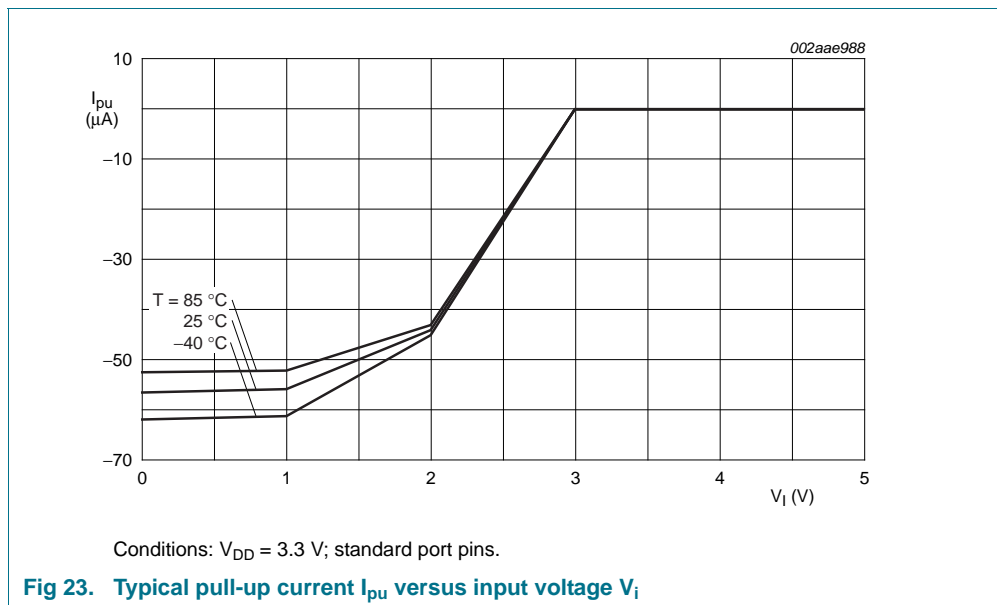
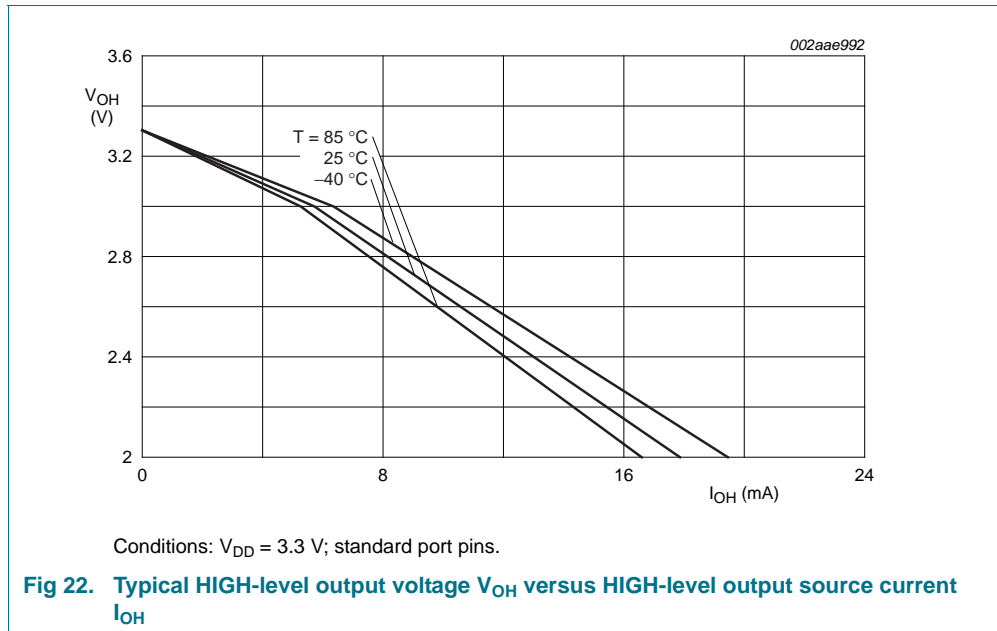

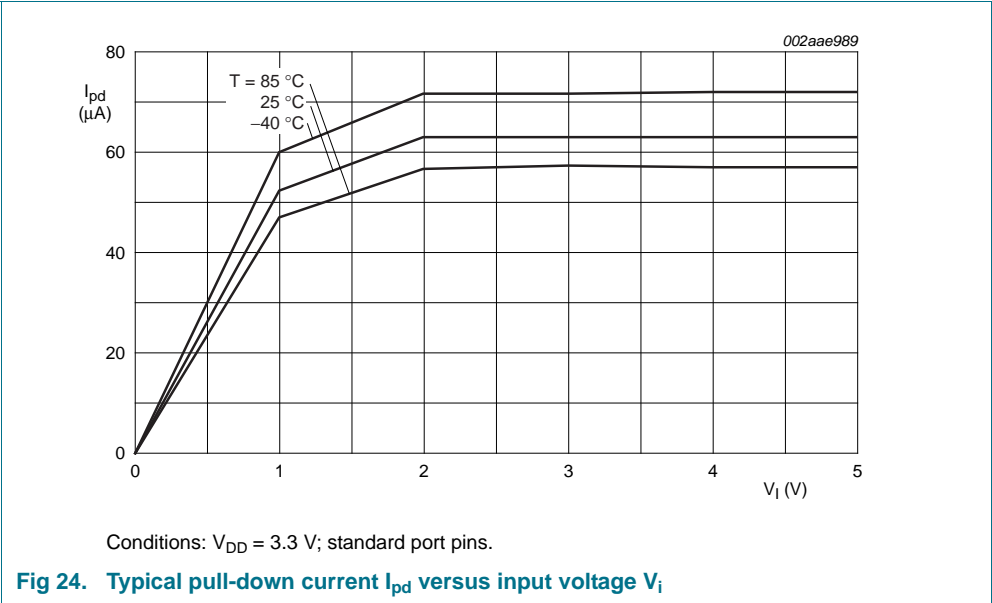

10. Dynamic characteristics

10.1 Power-up ramp conditions

Table 12. Power-up characteristics

$T_{amb} = -40\text{ }^{\circ}\text{C to }+85\text{ }^{\circ}\text{C}$.

Symbol	Parameter	Conditions	Min	Typ	Max	Unit
t_r	rise time	at $t = t_1$: $0 < V_I \leq 400\text{ mV}$	[1] 0	-	500	ms
t_{wait}	wait time		[1][2] 12	-	-	μs
V_I	input voltage	at $t = t_1$ on pin V_{DD}	0	-	400	mV

[1] See [Figure 25](#).

[2] The wait time specifies the time the power supply must be at levels below 400 mV before ramping up.

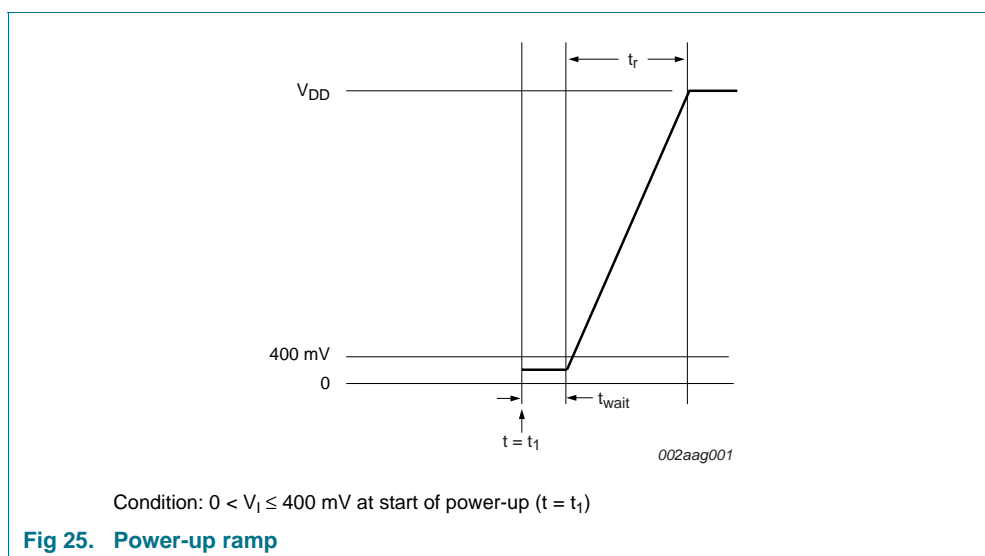

Fig 25. Power-up ramp

10.2 Flash memory

Table 13. Flash characteristics

$T_{amb} = -40\text{ }^{\circ}\text{C to }+85\text{ }^{\circ}\text{C}$, unless otherwise specified.

Symbol	Parameter	Conditions	Min	Typ	Max	Unit
N_{endu}	endurance		[1] 10000	100000	-	cycles
t_{ret}	retention time	powered	10	-	-	years
		unpowered	20	-	-	years
t_{er}	erase time	sector or multiple consecutive sectors	95	100	105	ms
t_{prog}	programming time		[2] 0.95	1	1.05	ms

[1] Number of program/erase cycles.

[2] Programming times are given for writing 256 bytes from RAM to the flash. Data must be written to the flash in blocks of 256 bytes.

10.3 External clock

Table 14. Dynamic characteristic: external clock
 $T_{amb} = -40\text{ }^{\circ}\text{C}$ to $+85\text{ }^{\circ}\text{C}$; V_{DD} over specified ranges.^[1]

Symbol	Parameter	Conditions	Min	Typ ^[2]	Max	Unit
f_{osc}	oscillator frequency		1	-	25	MHz
$T_{cy(clk)}$	clock cycle time		40	-	1000	ns
t_{CHCX}	clock HIGH time		$T_{cy(clk)} \times 0.4$	-	-	ns
t_{CLCX}	clock LOW time		$T_{cy(clk)} \times 0.4$	-	-	ns
t_{CLCH}	clock rise time		-	-	5	ns
t_{CHCL}	clock fall time		-	-	5	ns

- [1] Parameters are valid over operating temperature range unless otherwise specified.
- [2] Typical ratings are not guaranteed. The values listed are at room temperature (25 °C), nominal supply voltages.

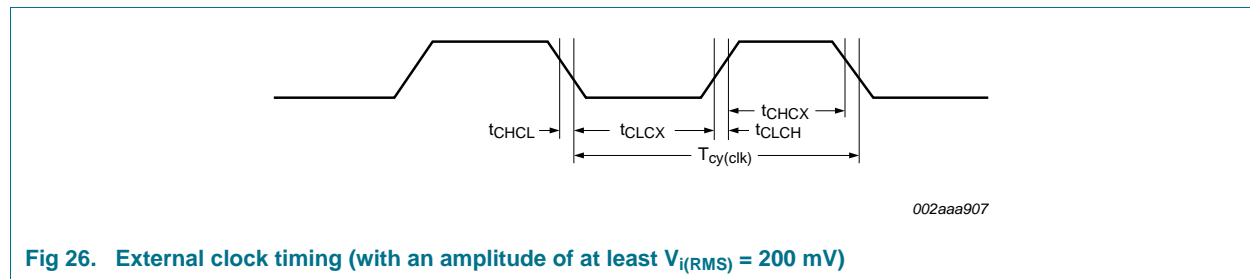

Fig 26. External clock timing (with an amplitude of at least $V_{i(RMS)} = 200\text{ mV}$)

10.4 Internal oscillators

Table 15. Dynamic characteristics: IRC

$T_{amb} = -40\text{ }^{\circ}\text{C}$ to $+85\text{ }^{\circ}\text{C}$; $2.7\text{ V} \leq V_{DD} \leq 3.6\text{ V}$ [1].

Symbol	Parameter	Conditions	Min	Typ[2]	Max	Unit
$f_{osc(RC)}$	internal RC oscillator frequency	-	11.88	12	12.12	MHz

- [1] Parameters are valid over operating temperature range unless otherwise specified.
- [2] Typical ratings are not guaranteed. The values listed are at room temperature (25 °C), nominal supply voltages.

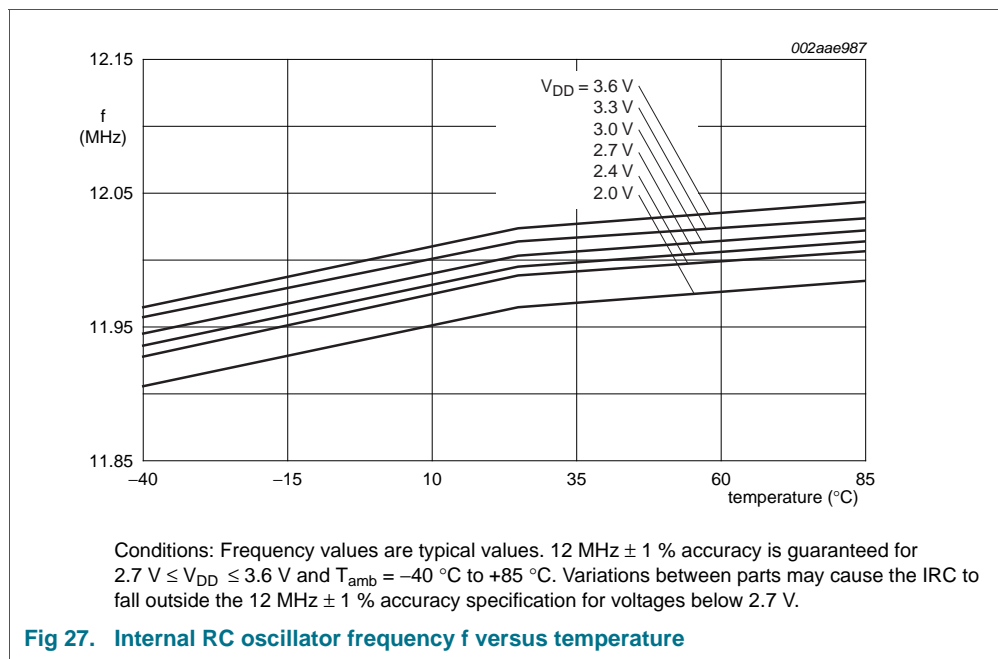

Fig 27. Internal RC oscillator frequency f versus temperature

Table 16. Dynamic characteristics: Watchdog oscillator

Symbol	Parameter	Conditions	Min	Typ[1]	Max	Unit
$f_{osc(int)}$	internal oscillator frequency	DIVSEL = 0x1F, FREQSEL = 0x1 in the WDTOSCCTRL register;	[2][3] -	7.8	-	kHz
		DIVSEL = 0x00, FREQSEL = 0xF in the WDTOSCCTRL register	[2][3] -	1700	-	kHz

- [1] Typical ratings are not guaranteed. The values listed are at nominal supply voltages.
- [2] The typical frequency spread over processing and temperature (T_{amb} = -40 °C to +85 °C) is ±40 %.
- [3] See the *LPC13xx user manual*.

10.5 I/O pins

Table 17. Dynamic characteristics: I/O pins^[1]

$T_{amb} = -40\text{ }^{\circ}\text{C to }+85\text{ }^{\circ}\text{C}; 3.0\text{ V} \leq V_{DD} \leq 3.6\text{ V}.$

Symbol	Parameter	Conditions	Min	Typ	Max	Unit
t_r	rise time	pin configured as output	3.0	-	5.0	ns
t_f	fall time	pin configured as output	2.5	-	5.0	ns

[1] Applies to standard port pins and RESET pin.

10.6 I²C-bus

Table 18. Dynamic characteristic: I²C-bus pins^[1]

$T_{amb} = -40\text{ }^{\circ}\text{C to }+85\text{ }^{\circ}\text{C}.$ ^[2]

Symbol	Parameter	Conditions	Min	Max	Unit
f_{SCL}	SCL clock frequency	Standard-mode	0	100	kHz
		Fast-mode	0	400	kHz
		Fast-mode Plus	0	1	MHz
t_f	fall time	^{[4][5][6][7]} of both SDA and SCL signals	-	300	ns
		Standard-mode			
		Fast-mode	$20 + 0.1 \times C_b$	300	ns
t_{LOW}	LOW period of the SCL clock	Standard-mode	4.7	-	μs
		Fast-mode	1.3	-	μs
		Fast-mode Plus	0.5	-	μs
t_{HIGH}	HIGH period of the SCL clock	Standard-mode	4.0	-	μs
		Fast-mode	0.6	-	μs
		Fast-mode Plus	0.26	-	μs
$t_{HD;DAT}$	data hold time	^{[3][4][8]} Standard-mode	0	-	μs
		Fast-mode	0	-	μs
		Fast-mode Plus	0	-	μs
$t_{SU;DAT}$	data set-up time	^{[9][10]} Standard-mode	250	-	ns
		Fast-mode	100	-	ns
		Fast-mode Plus	50	-	ns

[1] See the I²C-bus specification *UM10204* for details.

[2] Parameters are valid over operating temperature range unless otherwise specified.

[3] $t_{HD;DAT}$ is the data hold time that is measured from the falling edge of SCL; applies to data in transmission and the acknowledge.

[4] A device must internally provide a hold time of at least 300 ns for the SDA signal (with respect to the $V_{IH}(\text{min})$ of the SCL signal) to bridge the undefined region of the falling edge of SCL.

[5] C_b = total capacitance of one bus line in pF.

[6] The maximum t_f for the SDA and SCL bus lines is specified at 300 ns. The maximum fall time for the SDA output stage t_f is specified at 250 ns. This allows series protection resistors to be connected in between the SDA and the SCL pins and the SDA/SCL bus lines without exceeding the maximum specified t_f .

[7] In Fast-mode Plus, fall time is specified the same for both output stage and bus timing. If series resistors are used, designers should allow for this when considering bus timing.

- [8] The maximum $t_{HD,DAT}$ could be 3.45 μ s and 0.9 μ s for Standard-mode and Fast-mode but must be less than the maximum of $t_{VD,DAT}$ or $t_{VD,ACK}$ by a transition time (see *UM10204*). This maximum must only be met if the device does not stretch the LOW period (t_{LOW}) of the SCL signal. If the clock stretches the SCL, the data must be valid by the set-up time before it releases the clock.
- [9] $t_{SU,DAT}$ is the data set-up time that is measured with respect to the rising edge of SCL; applies to data in transmission and the acknowledge.
- [10] A Fast-mode I²C-bus device can be used in a Standard-mode I²C-bus system but the requirement $t_{SU,DAT} = 250$ ns must then be met. This will automatically be the case if the device does not stretch the LOW period of the SCL signal. If such a device does stretch the LOW period of the SCL signal, it must output the next data bit to the SDA line $t_{r(max)} + t_{SU,DAT} = 1000 + 250 = 1250$ ns (according to the Standard-mode I²C-bus specification) before the SCL line is released. Also the acknowledge timing must meet this set-up time.

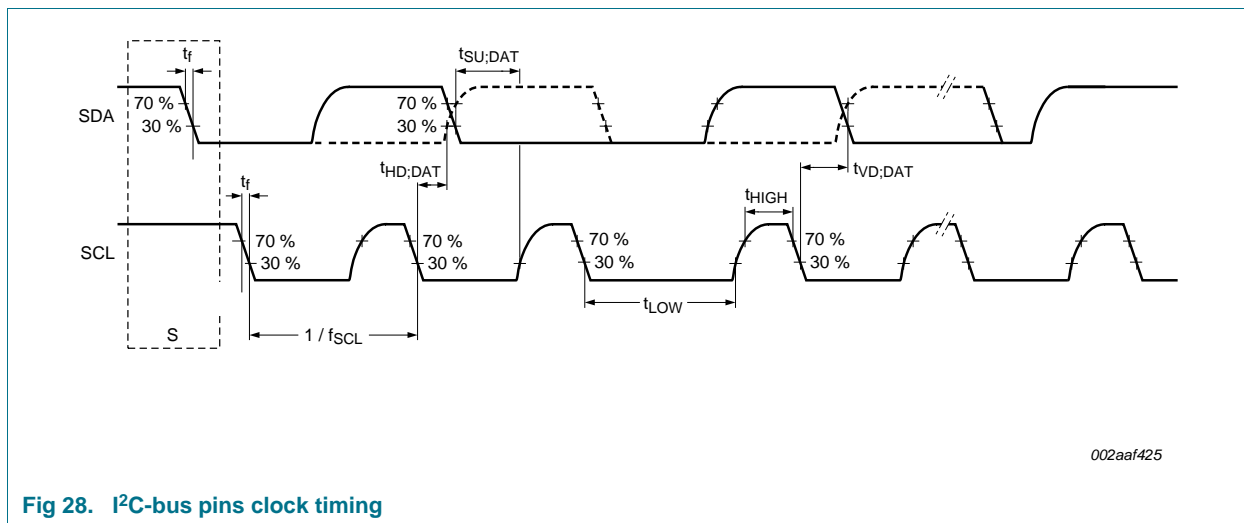

Fig 28. I²C-bus pins clock timing

10.7 SSP0/1 interface

Remark: The SSP1 interface is available on the LPC1313FBD48/01 only.

Table 19. Dynamic characteristics: SSP pins in SPI mode

Symbol	Parameter	Conditions	Min	Max	Unit
SSP master					
$T_{cy(\text{clk})}$	clock cycle time	full-duplex mode [1]	40	-	ns
		when only transmitting [1]	27.8	-	ns
t_{DS}	data set-up time	in SPI mode; $2.4\text{ V} \leq V_{DD} \leq 3.6\text{ V}$ [2]	15	-	ns
		$2.0\text{ V} \leq V_{DD} < 2.4\text{ V}$ [2]	20	-	ns
t_{DH}	data hold time	in SPI mode [2]	0	-	ns
$t_{v(Q)}$	data output valid time	in SPI mode [2]	-	10	ns
$t_{h(Q)}$	data output hold time	in SPI mode [2]	0	-	ns
SSP slave					
$T_{cy(\text{PCLK})}$	PCLK cycle time		13.9	-	ns
t_{DS}	data set-up time	in SPI mode [3][4]	0	-	ns
t_{DH}	data hold time	in SPI mode [3][4]	$3 \times T_{cy(\text{PCLK})} + 4$	-	ns
$t_{v(Q)}$	data output valid time	in SPI mode [3][4]	-	$3 \times T_{cy(\text{PCLK})} + 11$	ns
$t_{h(Q)}$	data output hold time	in SPI mode [3][4]	-	$2 \times T_{cy(\text{PCLK})} + 5$	ns

[1] $T_{cy(\text{clk})} = (\text{SSPCLKDIV} \times (1 + \text{SCR}) \times \text{CPSDVSR}) / f_{\text{main}}$. The clock cycle time derived from the SPI bit rate $T_{cy(\text{clk})}$ is a function of the main clock frequency f_{main} , the SSP peripheral clock divider (SSPCLKDIV), the SSP SCR parameter (specified in the SSP0CR0 register), and the SSP CPSDVSR parameter (specified in the SSP clock prescale register).

[2] $T_{\text{amb}} = -40\text{ }^{\circ}\text{C}$ to $+85\text{ }^{\circ}\text{C}$.

[3] $T_{cy(\text{clk})} = 12 \times T_{cy(\text{PCLK})}$.

[4] $T_{\text{amb}} = 25\text{ }^{\circ}\text{C}$; $V_{DD} = 3.3\text{ V}$.

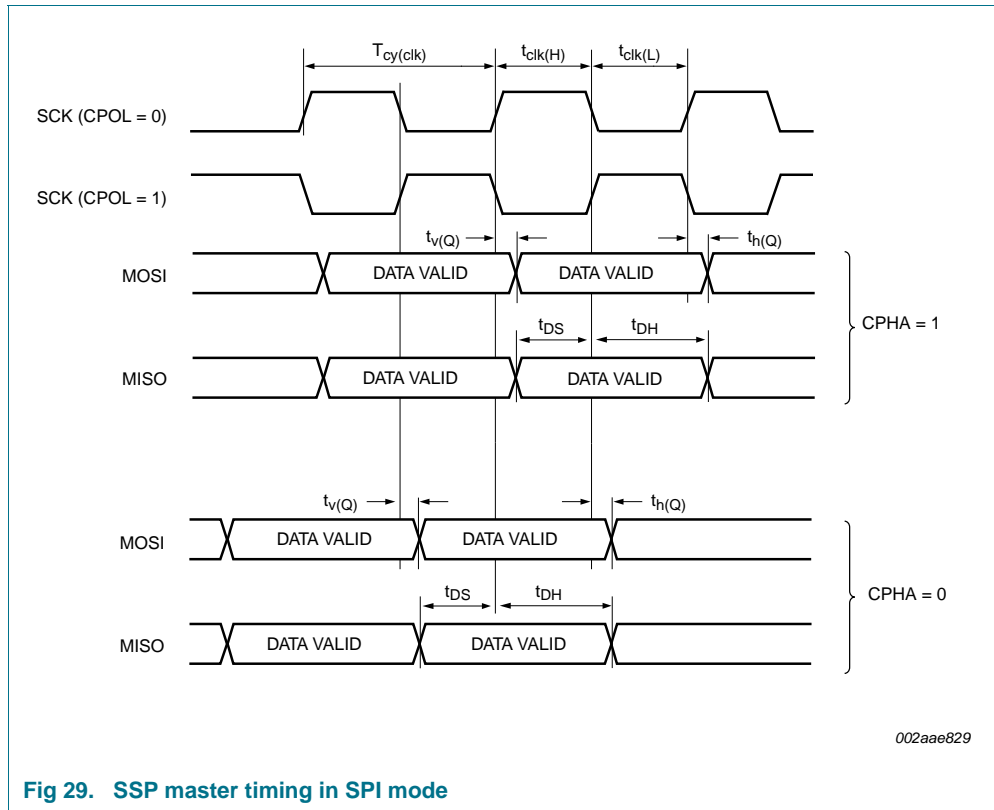

Fig 29. SSP master timing in SPI mode

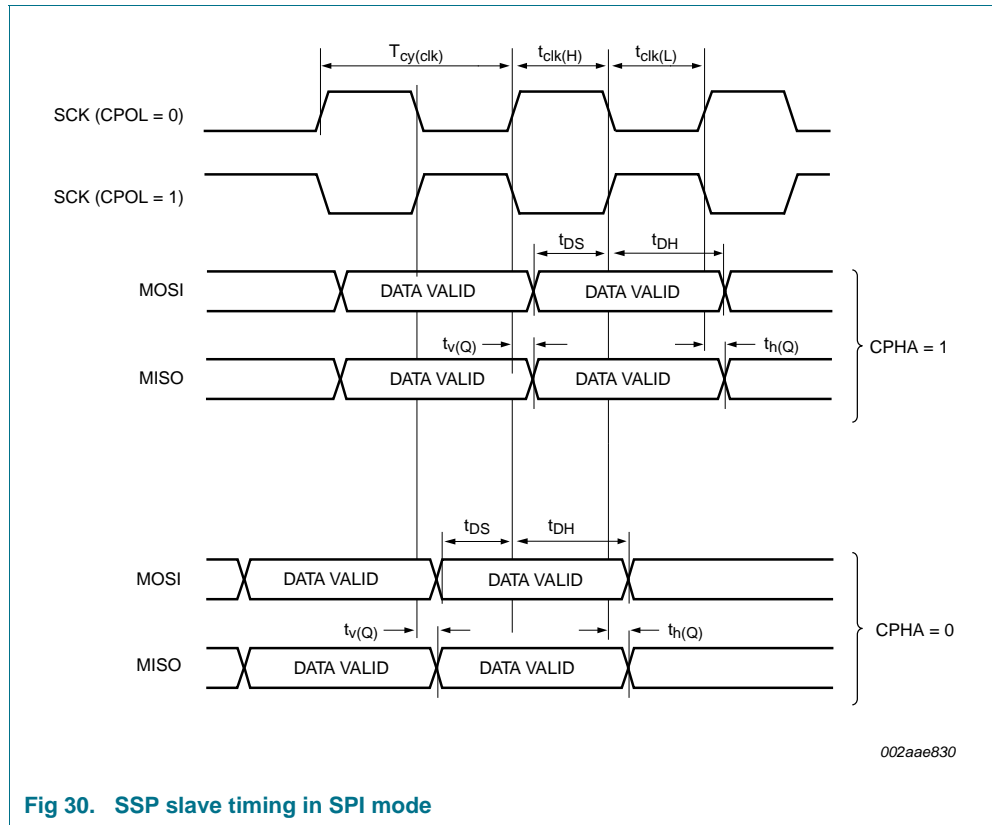

Fig 30. SSP slave timing in SPI mode

10.8 USB interface (LPC1342/43 only)

Table 20. Dynamic characteristics: USB pins (full-speed)

$C_L = 50\text{ pF}$; $R_{pu} = 1.5\text{ k}\Omega$ on D+ to V_{DD} , unless otherwise specified. $3.0\text{ V} \leq V_{DD} \leq 3.6\text{ V}$

Symbol	Parameter	Conditions	Min	Typ	Max	Unit
t_r	rise time	10 % to 90 %	8.5	-	13.8	ns
t_f	fall time	10 % to 90 %	7.7	-	13.7	ns
t_{FRFM}	differential rise and fall time matching	t_r / t_f	-	-	109	%
V_{CRS}	output signal crossover voltage		1.3	-	2.0	V
t_{FEOPT}	source SE0 interval of EOP	see Figure 31	160	-	175	ns
t_{FDEOP}	source jitter for differential transition to SE0 transition	see Figure 31	-2	-	+5	ns
t_{JR1}	receiver jitter to next transition		-18.5	-	+18.5	ns
t_{JR2}	receiver jitter for paired transitions	10 % to 90 %	-9	-	+9	ns
t_{EOPR1}	EOP width at receiver	must reject as EOP; see Figure 31	[1] 40	-	-	ns
t_{EOPR2}	EOP width at receiver	must accept as EOP; see Figure 31	[1] 82	-	-	ns

[1] Characterized but not implemented as production test. Guaranteed by design.

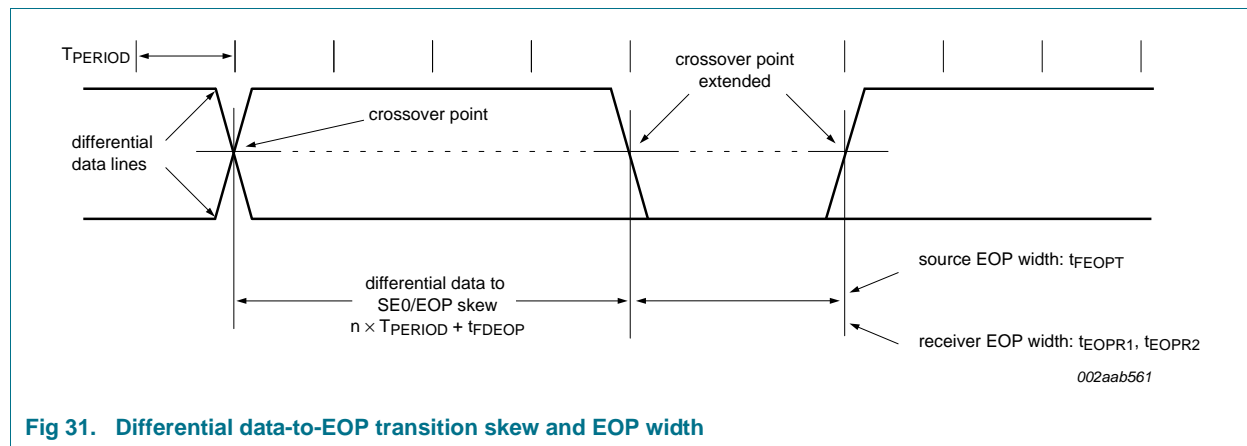
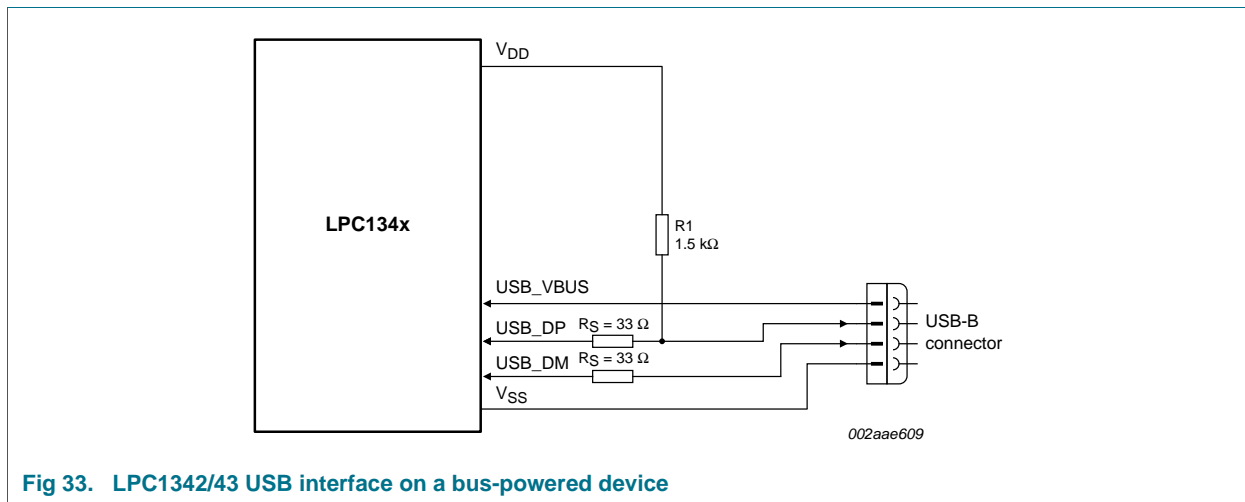
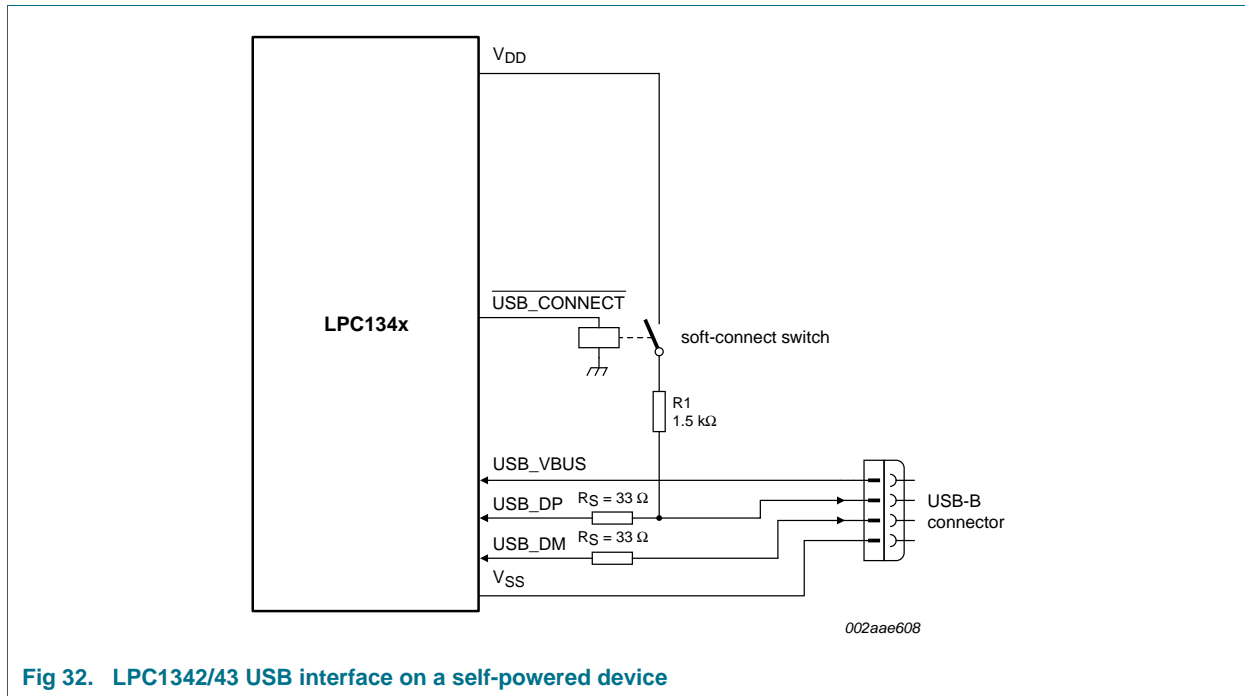

Fig 31. Differential data-to-EOP transition skew and EOP width

11. Application information

11.1 Suggested USB interface solutions (LPC1342/43 only)



11.2 XTAL input

The input voltage to the on-chip oscillators is limited to 1.8 V. If the oscillator is driven by a clock in slave mode, it is recommended that the input be coupled through a capacitor with $C_i = 100$ pF. To limit the input voltage to the specified range, choose an additional capacitor to ground C_g which attenuates the input voltage by a factor $C_i / (C_i + C_g)$. In slave mode, a minimum of 200 mV(RMS) is needed.

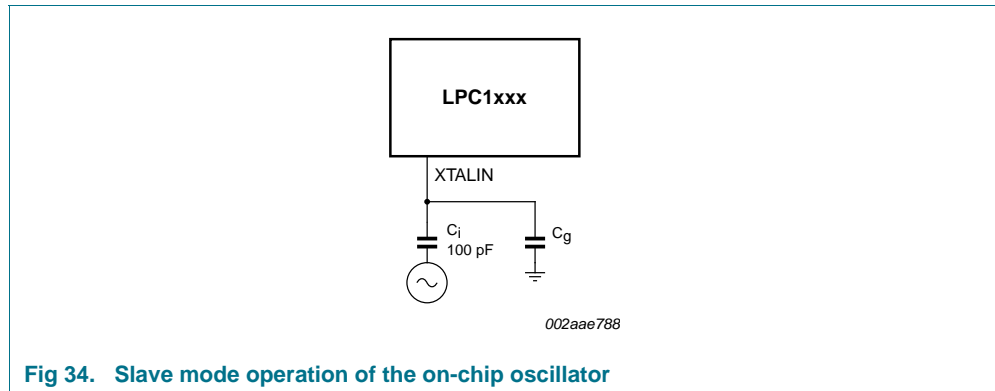

Fig 34. Slave mode operation of the on-chip oscillator

In slave mode the input clock signal should be coupled by means of a capacitor of 100 pF (Figure 34), with an amplitude between 200 mV(RMS) and 1000 mV(RMS). This corresponds to a square wave signal with a signal swing of between 280 mV and 1.4 V. The XTALOUT pin in this configuration can be left unconnected.

External components and models used in oscillation mode are shown in Figure 35 and in Table 21 and Table 22. Since the feedback resistance is integrated on chip, only a crystal and the capacitances C_{X1} and C_{X2} need to be connected externally in case of fundamental mode oscillation (the fundamental frequency is represented by L, C_L and R_S). Capacitance C_P in Figure 35 represents the parallel package capacitance and should not be larger than 7 pF. Parameters F_{OSC} , C_L , R_S and C_P are supplied by the crystal manufacturer.

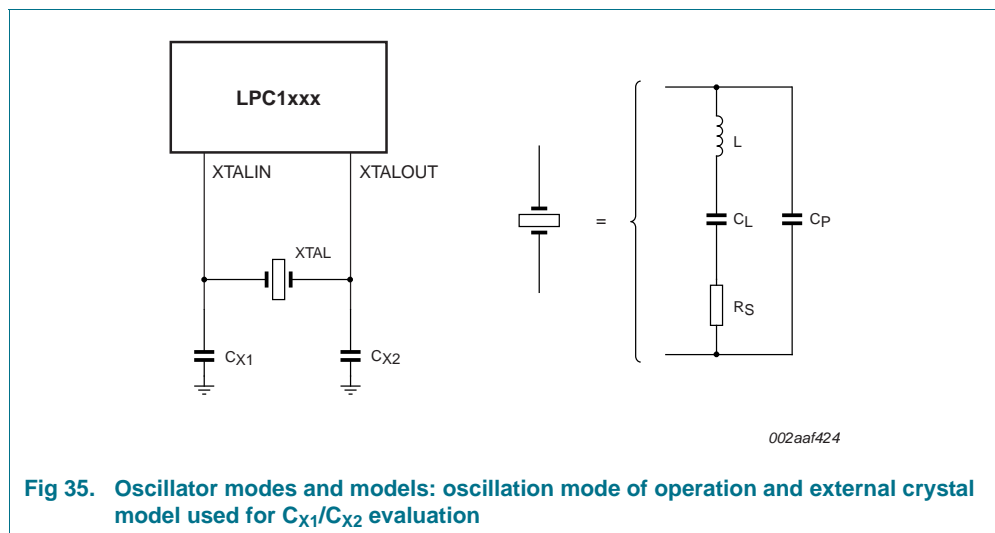

Fig 35. Oscillator modes and models: oscillation mode of operation and external crystal model used for C_{X1}/C_{X2} evaluation

Table 21. Recommended values for C_{X1}/C_{X2} in oscillation mode (crystal and external components parameters) low frequency mode

Fundamental oscillation frequency F_{Osc}	Crystal load capacitance C_L	Maximum crystal series resistance R_S	External load capacitors C_{X1}, C_{X2}
1 MHz - 5 MHz	10 pF	< 300 Ω	18 pF, 18 pF
	20 pF	< 300 Ω	39 pF, 39 pF
	30 pF	< 300 Ω	57 pF, 57 pF
5 MHz - 10 MHz	10 pF	< 300 Ω	18 pF, 18 pF
	20 pF	< 200 Ω	39 pF, 39 pF
	30 pF	< 100 Ω	57 pF, 57 pF
10 MHz - 15 MHz	10 pF	< 160 Ω	18 pF, 18 pF
	20 pF	< 60 Ω	39 pF, 39 pF
15 MHz - 20 MHz	10 pF	< 80 Ω	18 pF, 18 pF

Table 22. Recommended values for C_{X1}/C_{X2} in oscillation mode (crystal and external components parameters) high frequency mode

Fundamental oscillation frequency F_{Osc}	Crystal load capacitance C_L	Maximum crystal series resistance R_S	External load capacitors C_{X1}, C_{X2}
15 MHz - 20 MHz	10 pF	< 180 Ω	18 pF, 18 pF
	20 pF	< 100 Ω	39 pF, 39 pF
20 MHz - 25 MHz	10 pF	< 160 Ω	18 pF, 18 pF
	20 pF	< 80 Ω	39 pF, 39 pF

11.3 XTAL Printed-Circuit Board (PCB) layout guidelines

The crystal should be connected on the PCB as close as possible to the oscillator input and output pins of the chip. Take care that the load capacitors C_{X1} , C_{X2} , and C_{X3} in case of third overtone crystal usage have a common ground plane. The external components must also be connected to the ground plain. Loops must be made as small as possible in order to keep the noise coupled in via the PCB as small as possible. Also parasitics should stay as small as possible. Values of C_{X1} and C_{X2} should be chosen smaller accordingly to the increase in parasitics of the PCB layout.

11.4 Standard I/O pad configuration

Figure 36 shows the possible pin modes for standard I/O pins with analog input function:

- Digital output driver
- Digital input: Pull-up enabled/disabled
- Digital input: Pull-down enabled/disabled
- Digital input: Repeater mode enabled/disabled
- Analog input

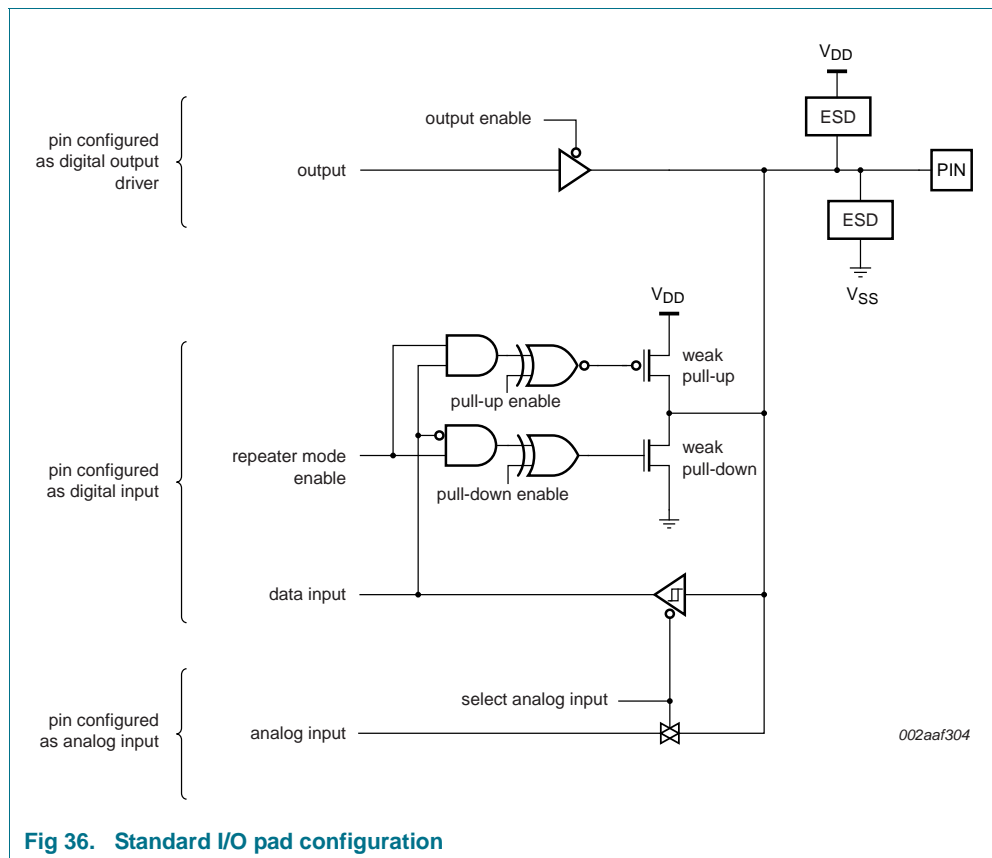

Fig 36. Standard I/O pad configuration

11.5 Reset pad configuration

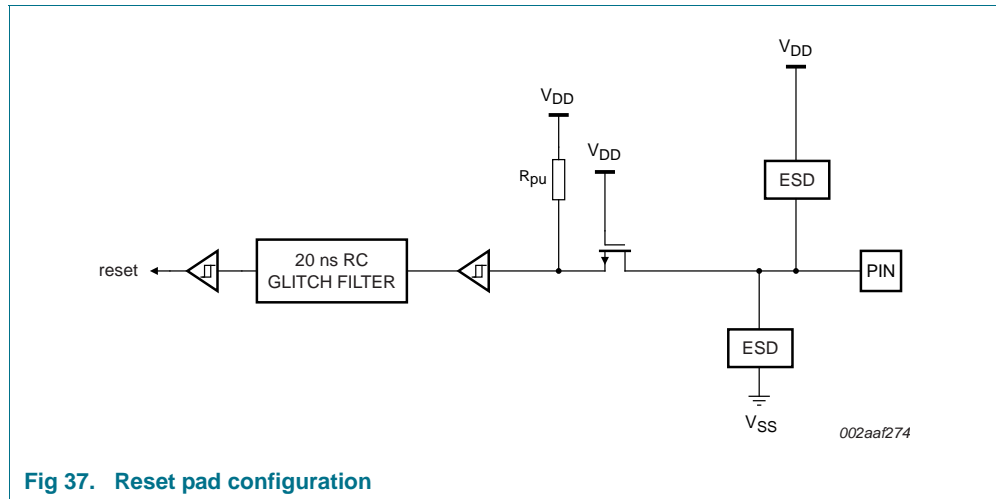

Fig 37. Reset pad configuration

11.6 ADC usage notes

The following guidelines show how to increase the performance of the ADC in a noisy environment beyond the ADC specifications listed in [Table 8](#):

- The ADC input trace must be short and as close as possible to the LPC1311/13/42/43 chip.
- The ADC input traces must be shielded from fast switching digital signals and noisy power supply lines.
- Because the ADC and the digital core share the same power supply, the power supply line must be adequately filtered.
- To improve the ADC performance in a very noisy environment, put the device in Sleep mode during the ADC conversion.

11.7 ElectroMagnetic Compatibility (EMC)

Radiated emission measurements according to the IEC61967-2 standard using the TEM-cell method are shown for the LPC1343FBD48 in [Table 23](#).

Table 23. ElectroMagnetic Compatibility (EMC) for part LPC1343FBD48 (TEM-cell method)
 $V_{DD} = 3.3\text{ V}$; $T_{amb} = 25\text{ °C}$.

Parameter	Frequency band	System clock =				Unit
		12 MHz	24 MHz	48 MHz	72 MHz	
Input clock: IRC (12 MHz)						
maximum peak level	150 kHz - 30 MHz	-6	-5	-7	-7	dB μ V
	30 MHz - 150 MHz	-1	+3	+9	+13	dB μ V
	150 MHz - 1 GHz	+3	+7	+15	+19	dB μ V
IEC level ^[1]	-	O	N	M	L	-
Input clock: crystal oscillator (12 MHz)						
maximum peak level	150 kHz - 30 MHz	-5	-5	-7	-7	dB μ V
	30 MHz - 150 MHz	0	+4	+9	+13	dB μ V
	150 MHz - 1 GHz	3	+8	+15	+20	dB μ V
IEC level ^[1]	-	O	N	M	L	-

[1] IEC levels refer to Appendix D in the IEC61967-2 Specification.

12. Package outline

LQFP48: plastic low profile quad flat package; 48 leads; body 7 x 7 x 1.4 mm

SOT313-2

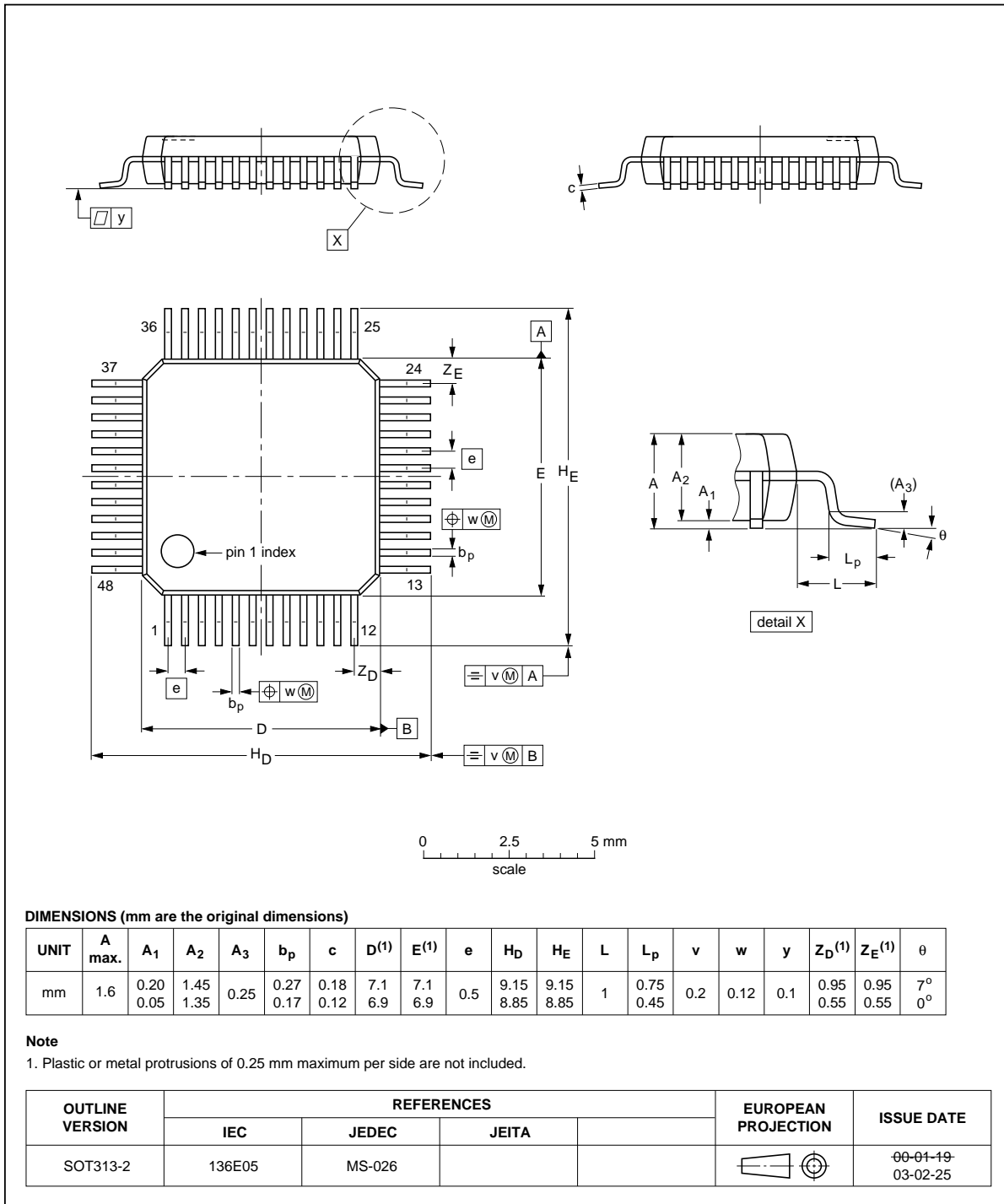

Fig 38. Package outline SOT313-2 (LQFP48)

HVQFN33: plastic thermal enhanced very thin quad flat package; no leads; 33 terminals; body 7 x 7 x 0.85 mm

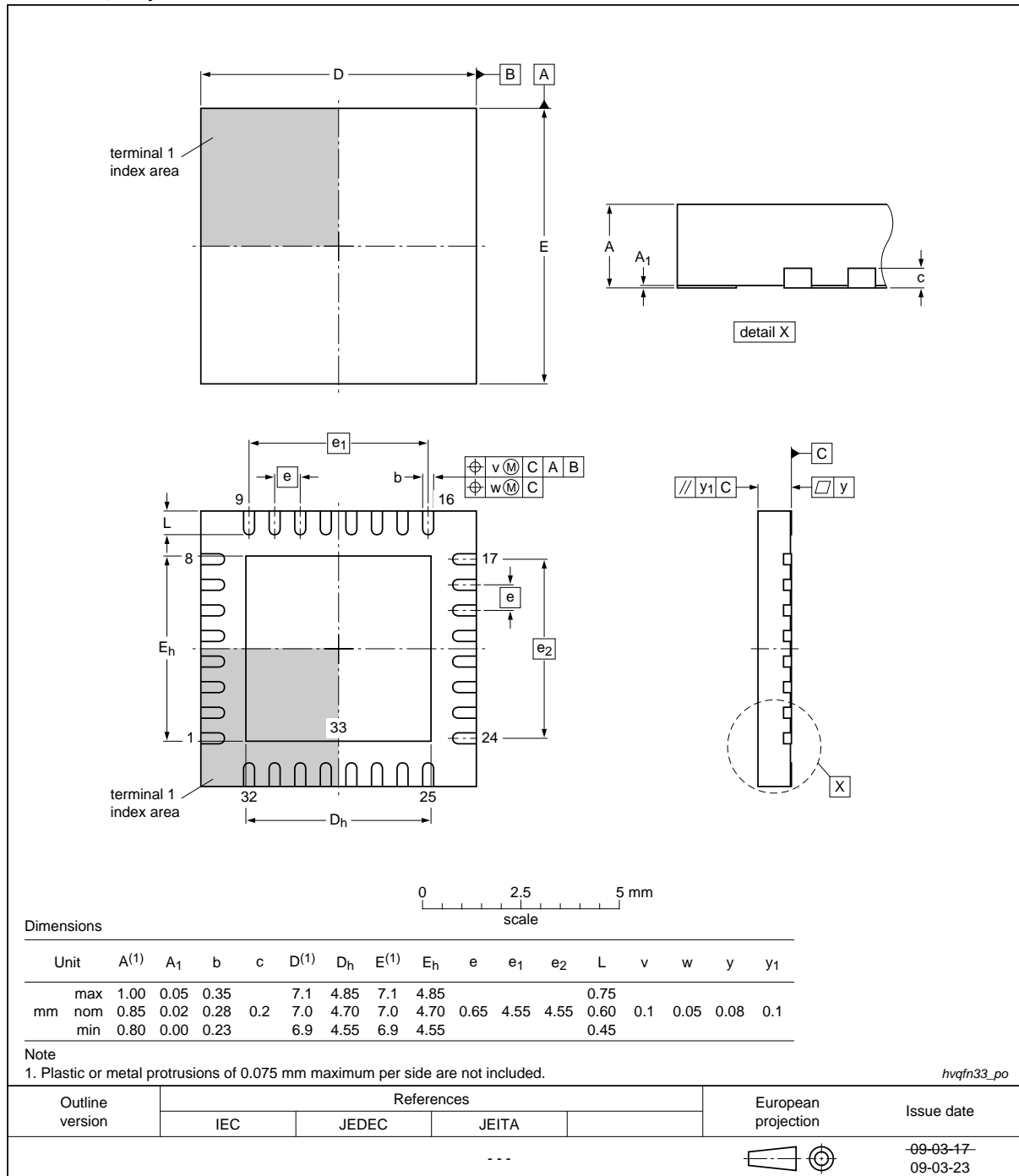
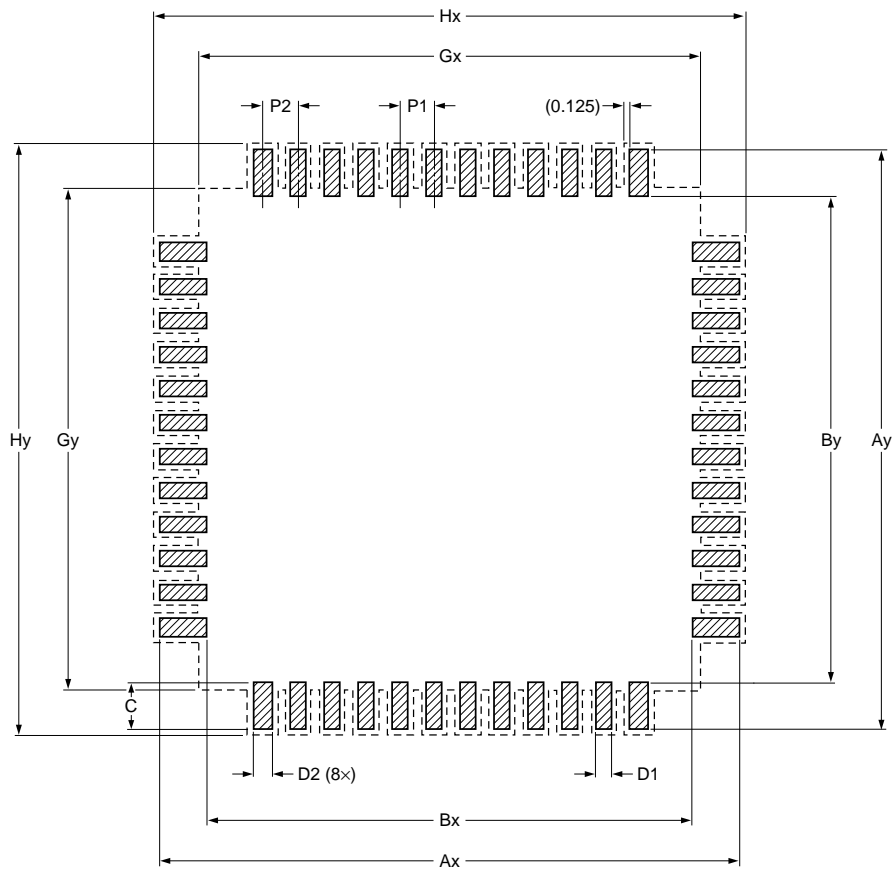

Fig 39. Package outline (HVQFN33)

13. Soldering

Footprint information for reflow soldering of LQFP48 package

SOT313-2



Generic footprint pattern
Refer to the package outline drawing for actual layout

 solder land
- - - - occupied area

DIMENSIONS in mm

P1	P2	Ax	Ay	Bx	By	C	D1	D2	Gx	Gy	Hx	Hy
0.500	0.560	10.350	10.350	7.350	7.350	1.500	0.280	0.500	7.500	7.500	10.650	10.650

sot313-2_fr

Fig 40. Reflow soldering of the LQFP48 package

Footprint information for reflow soldering of HVQFN33 package

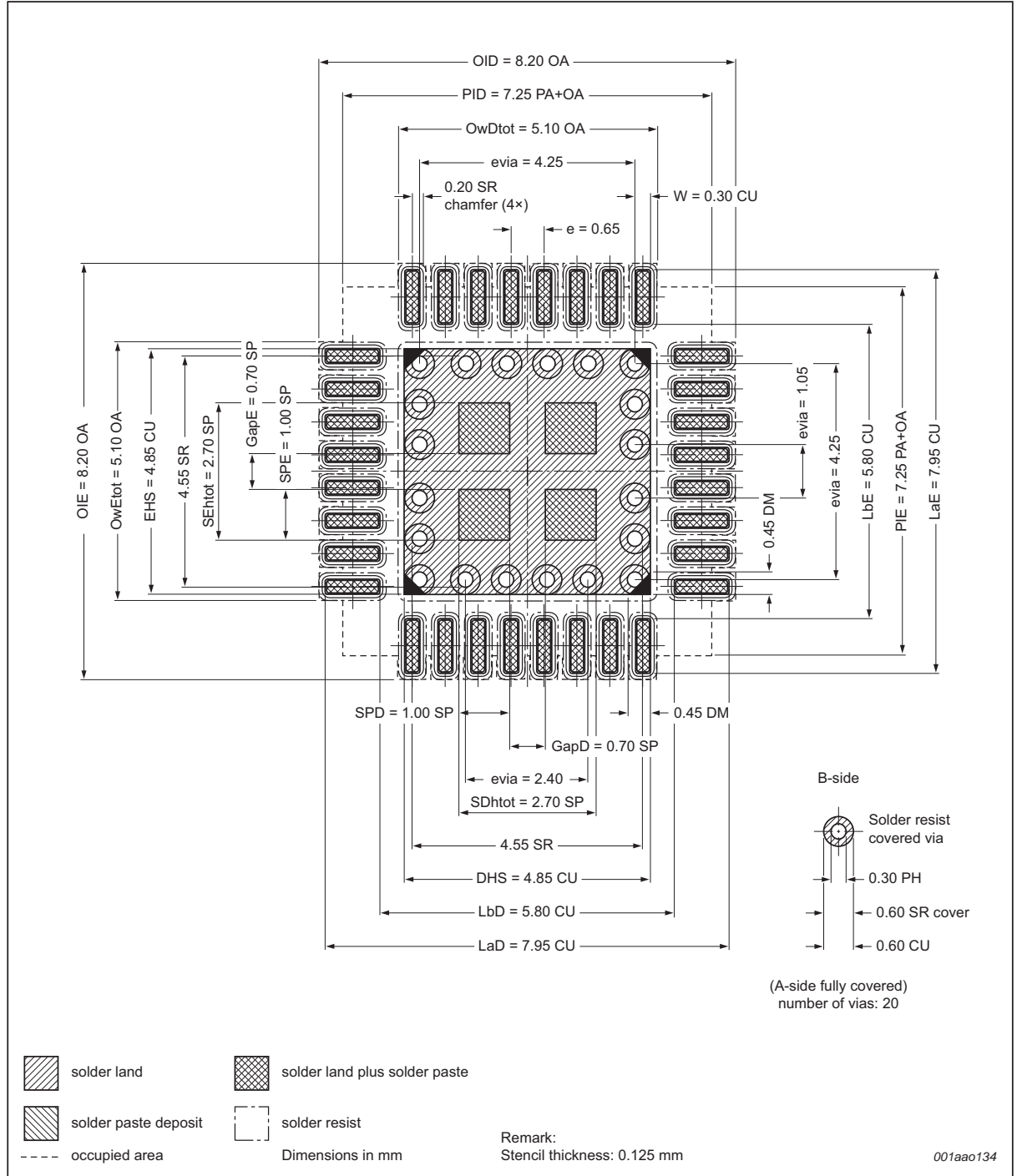

Fig 41. Reflow soldering of the HVQFN33 package

14. Abbreviations

Table 24. Abbreviations

Acronym	Description
A/D	Analog-to-Digital
ADC	Analog-to-Digital Converter
AHB	Advanced High-performance Bus
AMBA	Advanced Microcontroller Bus Architecture
APB	Advanced Peripheral Bus
BOD	BrownOut Detection
EOP	End Of Packet
ETM	Embedded Trace Macrocell
FIFO	First-In, First-Out
GPIO	General Purpose Input/Output
HID	Human Interface Device
I/O	Input/Output
LSB	Least Significant Bit
MSC	Mass Storage Class
PHY	Physical Layer
PLL	Phase-Locked Loop
SE0	Single Ended Zero
SPI	Serial Peripheral Interface
SSI	Serial Synchronous Interface
SSP	Synchronous Serial Port
SoF	Start-of-Frame
TCM	Tightly-Coupled Memory
TTL	Transistor-Transistor Logic
UART	Universal Asynchronous Receiver/Transmitter
USB	Universal Serial Bus

15. Revision history

Table 25. Revision history

Document ID	Release date	Data sheet status	Change notice	Supersedes
LPC1311_13_42_43 v.5	20120606	Product data sheet	-	LPC1311_13_42_43 v.4
Modifications:		<ul style="list-style-type: none"> Parameters V_{OL}, V_{OH}, I_{OL}, I_{OH} updated for voltage range $2.0\text{ V} \leq V_{DD} < 2.5\text{ V}$ in Table 7. Condition "The peak current is limited to 25 times the corresponding maximum current." removed from parameters I_{DD} and I_{SS} in Table 6. 		
LPC1311_13_42_43 v.4	20110620	Product data sheet	-	LPC1311_13_42_43 v.3
LPC1311_13_42_43 v.3	20100810	Product data sheet	-	LPC1311_13_42_43 v.2
LPC1311_13_42_43 v.2	20100506	Product data sheet	-	LPC1311_13_42_43 v.1
LPC1311_13_42_43 v.1	20091211	Product data sheet	-	-

16. Legal information

16.1 Data sheet status

Document status ^{[1][2]}	Product status ^[3]	Definition
Objective [short] data sheet	Development	This document contains data from the objective specification for product development.
Preliminary [short] data sheet	Qualification	This document contains data from the preliminary specification.
Product [short] data sheet	Production	This document contains the product specification.

[1] Please consult the most recently issued document before initiating or completing a design.

[2] The term 'short data sheet' is explained in section "Definitions".

[3] The product status of device(s) described in this document may have changed since this document was published and may differ in case of multiple devices. The latest product status information is available on the Internet at URL <http://www.nxp.com>.

16.2 Definitions

Draft — The document is a draft version only. The content is still under internal review and subject to formal approval, which may result in modifications or additions. NXP Semiconductors does not give any representations or warranties as to the accuracy or completeness of information included herein and shall have no liability for the consequences of use of such information.

Short data sheet — A short data sheet is an extract from a full data sheet with the same product type number(s) and title. A short data sheet is intended for quick reference only and should not be relied upon to contain detailed and full information. For detailed and full information see the relevant full data sheet, which is available on request via the local NXP Semiconductors sales office. In case of any inconsistency or conflict with the short data sheet, the full data sheet shall prevail.

Product specification — The information and data provided in a Product data sheet shall define the specification of the product as agreed between NXP Semiconductors and its customer, unless NXP Semiconductors and customer have explicitly agreed otherwise in writing. In no event however, shall an agreement be valid in which the NXP Semiconductors product is deemed to offer functions and qualities beyond those described in the Product data sheet.

16.3 Disclaimers

Limited warranty and liability — Information in this document is believed to be accurate and reliable. However, NXP Semiconductors does not give any representations or warranties, expressed or implied, as to the accuracy or completeness of such information and shall have no liability for the consequences of use of such information. NXP Semiconductors takes no responsibility for the content in this document if provided by an information source outside of NXP Semiconductors.

In no event shall NXP Semiconductors be liable for any indirect, incidental, punitive, special or consequential damages (including - without limitation - lost profits, lost savings, business interruption, costs related to the removal or replacement of any products or rework charges) whether or not such damages are based on tort (including negligence), warranty, breach of contract or any other legal theory.

Notwithstanding any damages that customer might incur for any reason whatsoever, NXP Semiconductors' aggregate and cumulative liability towards customer for the products described herein shall be limited in accordance with the *Terms and conditions of commercial sale* of NXP Semiconductors.

Right to make changes — NXP Semiconductors reserves the right to make changes to information published in this document, including without limitation specifications and product descriptions, at any time and without notice. This document supersedes and replaces all information supplied prior to the publication hereof.

Suitability for use — NXP Semiconductors products are not designed, authorized or warranted to be suitable for use in life support, life-critical or safety-critical systems or equipment, nor in applications where failure or malfunction of an NXP Semiconductors product can reasonably be expected to result in personal injury, death or severe property or environmental damage. NXP Semiconductors and its suppliers accept no liability for inclusion and/or use of NXP Semiconductors products in such equipment or applications and therefore such inclusion and/or use is at the customer's own risk.

Applications — Applications that are described herein for any of these products are for illustrative purposes only. NXP Semiconductors makes no representation or warranty that such applications will be suitable for the specified use without further testing or modification.

Customers are responsible for the design and operation of their applications and products using NXP Semiconductors products, and NXP Semiconductors accepts no liability for any assistance with applications or customer product design. It is customer's sole responsibility to determine whether the NXP Semiconductors product is suitable and fit for the customer's applications and products planned, as well as for the planned application and use of customer's third party customer(s). Customers should provide appropriate design and operating safeguards to minimize the risks associated with their applications and products.

NXP Semiconductors does not accept any liability related to any default, damage, costs or problem which is based on any weakness or default in the customer's applications or products, or the application or use by customer's third party customer(s). Customer is responsible for doing all necessary testing for the customer's applications and products using NXP Semiconductors products in order to avoid a default of the applications and the products or of the application or use by customer's third party customer(s). NXP does not accept any liability in this respect.

Limiting values — Stress above one or more limiting values (as defined in the Absolute Maximum Ratings System of IEC 60134) will cause permanent damage to the device. Limiting values are stress ratings only and (proper) operation of the device at these or any other conditions above those given in the Recommended operating conditions section (if present) or the Characteristics sections of this document is not warranted. Constant or repeated exposure to limiting values will permanently and irreversibly affect the quality and reliability of the device.

Terms and conditions of commercial sale — NXP Semiconductors products are sold subject to the general terms and conditions of commercial sale, as published at <http://www.nxp.com/profile/terms>, unless otherwise agreed in a valid written individual agreement. In case an individual agreement is concluded only the terms and conditions of the respective agreement shall apply. NXP Semiconductors hereby expressly objects to applying the customer's general terms and conditions with regard to the purchase of NXP Semiconductors products by customer.

No offer to sell or license — Nothing in this document may be interpreted or construed as an offer to sell products that is open for acceptance or the grant, conveyance or implication of any license under any copyrights, patents or other industrial or intellectual property rights.

Export control — This document as well as the item(s) described herein may be subject to export control regulations. Export might require a prior authorization from competent authorities.

Non-automotive qualified products — Unless this data sheet expressly states that this specific NXP Semiconductors product is automotive qualified, the product is not suitable for automotive use. It is neither qualified nor tested in accordance with automotive testing or application requirements. NXP Semiconductors accepts no liability for inclusion and/or use of non-automotive qualified products in automotive equipment or applications.

In the event that customer uses the product for design-in and use in automotive applications to automotive specifications and standards, customer (a) shall use the product without NXP Semiconductors' warranty of the product for such automotive applications, use and specifications, and (b)

whenever customer uses the product for automotive applications beyond NXP Semiconductors' specifications such use shall be solely at customer's own risk, and (c) customer fully indemnifies NXP Semiconductors for any liability, damages or failed product claims resulting from customer design and use of the product for automotive applications beyond NXP Semiconductors' standard warranty and NXP Semiconductors' product specifications.

16.4 Trademarks

Notice: All referenced brands, product names, service names and trademarks are the property of their respective owners.

I²C-bus — logo is a trademark of NXP B.V.

17. Contact information

For more information, please visit: <http://www.nxp.com>

For sales office addresses, please send an email to: salesaddresses@nxp.com

18. Contents

1	General description	1	7.18.4	Wake-up process	26
2	Features and benefits	1	7.18.5	Power control	27
3	Applications	3	7.18.5.1	Power profiles (LPC1300L series, LPC1311/01 and LPC1313/01 only)	27
4	Ordering information	3	7.18.5.2	Sleep mode	27
4.1	Ordering options	3	7.18.5.3	Deep-sleep mode	27
5	Block diagram	5	7.18.5.4	Deep power-down mode	28
6	Pinning information	6	7.19	System control	28
6.1	Pinning	6	7.19.1	Start logic	28
6.2	Pin description	10	7.19.2	Reset	28
7	Functional description	17	7.19.3	Brownout detection	28
7.1	Architectural overview	17	7.19.4	Code security (Code Read Protection - CRP)	28
7.2	ARM Cortex-M3 processor	17	7.19.5	Boot loader	29
7.3	On-chip flash program memory	17	7.19.6	APB interface	29
7.4	On-chip SRAM	17	7.19.7	AHB-Lite	29
7.5	Memory map	17	7.19.8	External interrupt inputs	29
7.6	Nested Vectored Interrupt Controller (NVIC)	18	7.19.9	Memory mapping control	29
7.6.1	Features	19	7.20	Emulation and debugging	30
7.6.2	Interrupt sources	19	8	Limiting values	31
7.7	IOCONFIG block	19	9	Static characteristics	32
7.8	Fast general purpose parallel I/O	19	9.1	BOD static characteristics for LPC1300 series	38
7.8.1	Features	19	9.2	BOD static characteristics for LPC1300L series (LPC1311/01 and LPC1313/01)	39
7.9	USB interface (LPC1342/43 only)	20	9.3	Power consumption for LPC1300 series	39
7.9.1	Full-speed USB device controller	20	9.4	Power consumption for LPC1300L series (LPC1311/01 and LPC1313/01)	42
7.9.1.1	Features	20	9.5	Peripheral power consumption	45
7.10	UART	21	9.6	Electrical pin characteristics	46
7.10.1	Features	21	10	Dynamic characteristics	50
7.11	SSP serial I/O controller	21	10.1	Power-up ramp conditions	50
7.11.1	Features	21	10.2	Flash memory	50
7.12	I ² C-bus serial I/O controller	21	10.3	External clock	51
7.12.1	Features	22	10.4	Internal oscillators	52
7.13	10-bit ADC	22	10.5	I/O pins	53
7.13.1	Features	22	10.6	I ² C-bus	53
7.14	General purpose external event counter/timers	23	10.7	SSP0/1 interface	55
7.14.1	Features	23	10.8	USB interface (LPC1342/43 only)	58
7.15	System tick timer	23	11	Application information	59
7.16	Watchdog timer	23	11.1	Suggested USB interface solutions (LPC1342/43 only)	59
7.16.1	Features	23	11.2	XTAL input	59
7.17	Windowed WatchDog Timer (WWDT)	24	11.3	XTAL Printed-Circuit Board (PCB) layout guidelines	61
7.17.1	Features	24	11.4	Standard I/O pad configuration	62
7.18	Clocking and power control	24	11.5	Reset pad configuration	63
7.18.1	Integrated oscillators	24	11.6	ADC usage notes	63
7.18.1.1	Internal RC oscillator	25	11.7	ElectroMagnetic Compatibility (EMC)	64
7.18.1.2	System oscillator	26			
7.18.1.3	Watchdog oscillator	26			
7.18.2	System PLL and USB PLL	26			
7.18.3	Clock output	26			

continued >>

12	Package outline	65
13	Soldering	67
14	Abbreviations	69
15	Revision history	70
16	Legal information	71
16.1	Data sheet status	71
16.2	Definitions	71
16.3	Disclaimers	71
16.4	Trademarks	72
17	Contact information	72
18	Contents	73

Please be aware that important notices concerning this document and the product(s) described herein, have been included in section 'Legal information'.

© NXP B.V. 2012.

All rights reserved.

For more information, please visit: <http://www.nxp.com>

For sales office addresses, please send an email to: salesaddresses@nxp.com

Date of release: 6 June 2012

Document identifier: LPC1311_13_42_43