

RoHS **Pb** **GREEN** **SP1003 Lead-Free/Green Series**



Description

Zener diodes fabricated in a proprietary silicon avalanche technology protect each I/O pin to provide a high level of protection for electronic equipment that may experience destructive electrostatic discharges (ESD). These robust diodes can safely absorb repetitive ESD strikes at $\pm 25\text{kV}$ (contact discharge, IEC 61000-4-2) without performance degradation. Additionally, each diode can safely dissipate 7A of 8/20 μs surge current (IEC61000-4-5) with very low clamping voltages.

Pinout

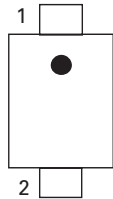

Features

- ESD, IEC61000-4-2, $\pm 25\text{kV}$ contact, $\pm 30\text{kV}$ air
- EFT, IEC61000-4-4, 40A (5/50ns)
- Lightning, IEC61000-4-5, 7A (8/20 μs)
- Low leakage current of 1 μA (MAX) at 5V
- Tiny SOD723 package saves board space
- Fits solder footprint of industry standard 0402 (1005) devices

Functional Block Diagram



Applications

- Mobile phones
- Smart phones
- PDAs
- Portable navigation devices
- Digital cameras
- Portable medical devices

Lead-Free/Green SP1003

Absolute Maximum Ratings

Symbol	Parameter	Value	Units
I_{PP}	Peak Pulse Current ($t_p=8/20\mu s$)	7.0	A
T_{OP}	Operating Temperature	-40 to 85	°C
T_{STOR}	Storage Temperature	-60 to 150	°C

CAUTION: Stresses above those listed in "Absolute Maximum Ratings" may cause permanent damage to the device. This is a stress only rating and operation of the device at these or any other conditions above those indicated in the operational sections of this specification is not implied.

Thermal Information

Parameter	Rating	Units
Storage Temperature Range	-65 to 150	°C
Maximum Junction Temperature	150	°C
Maximum Lead Temperature (Soldering 10s)	260	°C

Electrical Characteristics ($T_{OP}=25^\circ C$)

Parameter	Symbol	Test Conditions	Min	Typ	Max	Units
Forward Voltage Drop	V_F	$I_F = 10mA$		0.8	1.2	V
Reverse Voltage Drop	V_R	$I_R = 1mA$	6.0	7.0	8.0	V
Reverse Standoff Voltage	V_{RWM}	$I_R \leq 1\mu A$			5.0	V
Reverse Leakage Current	I_{LEAK}	$V_R = 5V$			1	μA
Clamp Voltage @ MAX I_{PP}^1	V_C	$t_p = 8/20\mu s$ (IEC61000-4-5)		12.5		V
ESD Withstand Voltage ¹	V_{ESD}	IEC61000-4-2 (Contact Discharge)	± 25			kV
		IEC61000-4-2 (Air Discharge)	± 30			kV
Diode Capacitance ¹	C_D	Reverse Bias=0V		30		pF

Note: ¹ Parameter is guaranteed by design and/or device characterization.

Capacitance vs. Reverse Bias

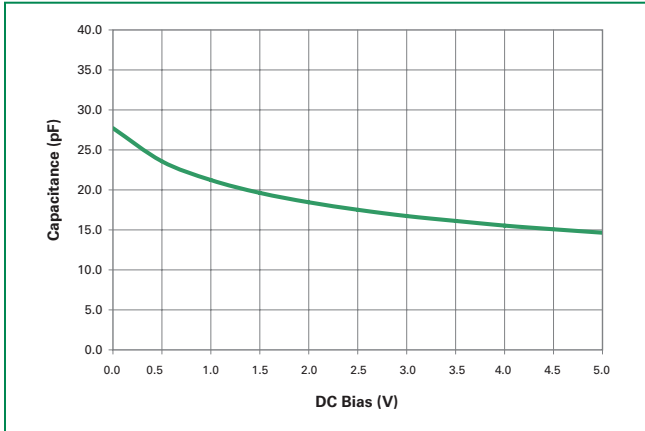

Pulse Waveform

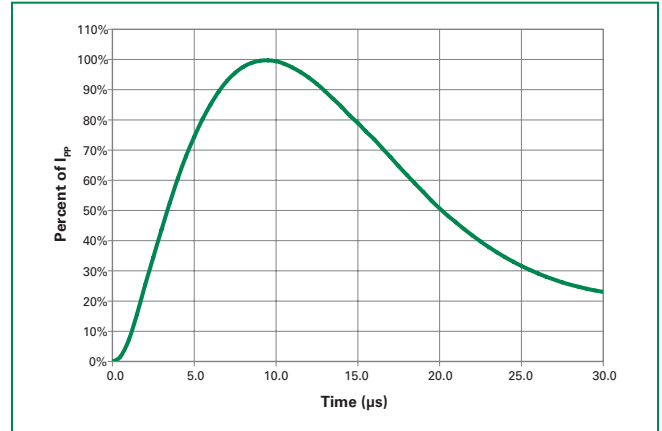

Clamping Voltage vs. I_{pp}

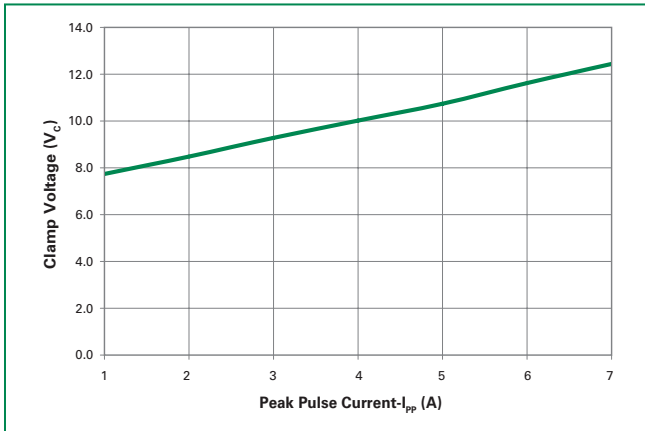

Lead-Free/Green SP1003

Application Example

Dx: SP1003-01DTG Discrete Diodes

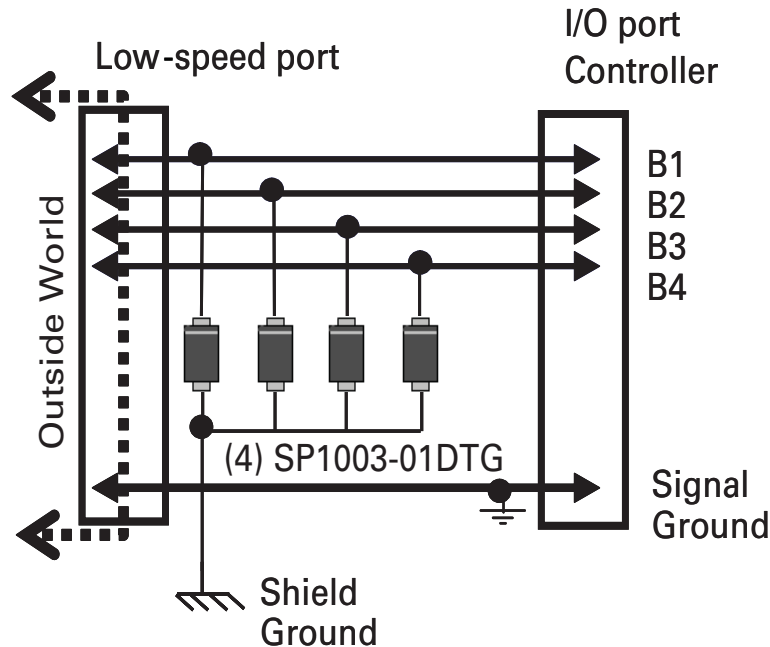

Soldering Parameters

Reflow Condition	Pb – Free assembly	
Pre Heat	- Temperature Min ($T_{s(min)}$)	150°C
	- Temperature Max ($T_{s(max)}$)	200°C
	- Time (min to max) (t_s)	60 – 180 secs
Average ramp up rate (Liquidus) Temp (T_L) to peak	3°C/second max	
$T_{s(max)}$ to T_L - Ramp-up Rate	3°C/second max	
Reflow	- Temperature (T_L) (Liquidus)	217°C
	- Temperature (t_L)	60 – 150 seconds
Peak Temperature (T_p)	250 ^{+0/-5} °C	
Time within 5°C of actual peak Temperature (t_p)	20 – 40 seconds	
Ramp-down Rate	6°C/second max	
Time 25°C to peak Temperature (T_p)	8 minutes Max.	
Do not exceed	260°C	

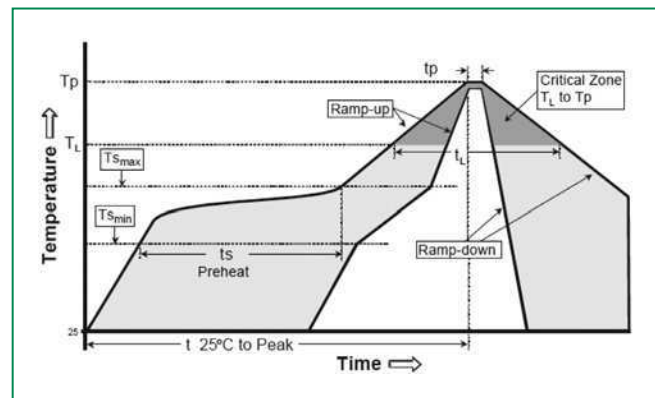

Package Dimensions - SOD723

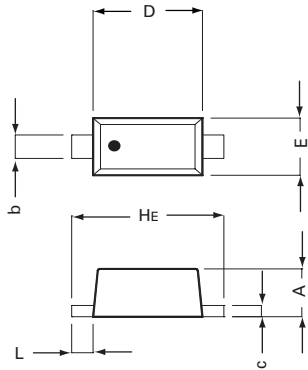

Symbol	SOD723			
	Millimeters		Inches	
	Min	Max	Min	Max
A	0.46	0.51	0.018	0.020
b	0.23	0.28	0.009	0.011
c	0.08	0.13	0.003	0.005
D	0.99	1.04	0.039	0.041
E	0.58	0.64	0.023	0.025
HE	1.37	1.47	0.054	0.058
L	0.15	0.25	0.006	0.010

Recommended Solder Pad Layout
Millimeters (Inches)

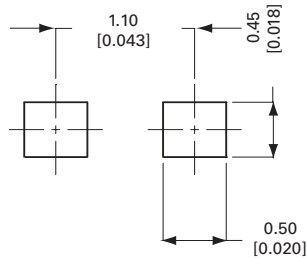

Lead-Free/Green SP1003

Part Numbering System

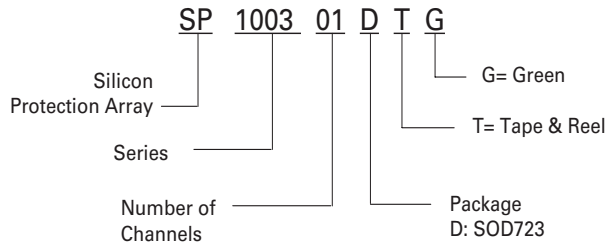

Product Characteristics

Lead Plating	Pre-Plated Frame
Lead Material	Copper Alloy
Lead Coplanarity	0.0004 inches (0.102mm)
Substitute Material	Silicon
Body Material	Molded Epoxy
Flammability	UL94-V-0

Notes :

1. All dimensions are in millimeters
2. Dimensions include solder plating.
3. Dimensions are exclusive of mold flash & metal burr.
4. All specifications comply to JEDEC SPEC MO-223 Issue A
5. Blo is facing up for mold and facing down for trim/form, i.e. reverse trim/form.
6. Package surface matte finish VDI 11-13.

Part Marking System

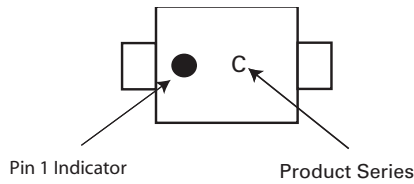

Ordering Information

Part Number	Package	Marking	Min. Order Qty.
SP1003-01DTG	SOD723	C	8000

Embossed Carrier Tape & Reel Specification – SOD723

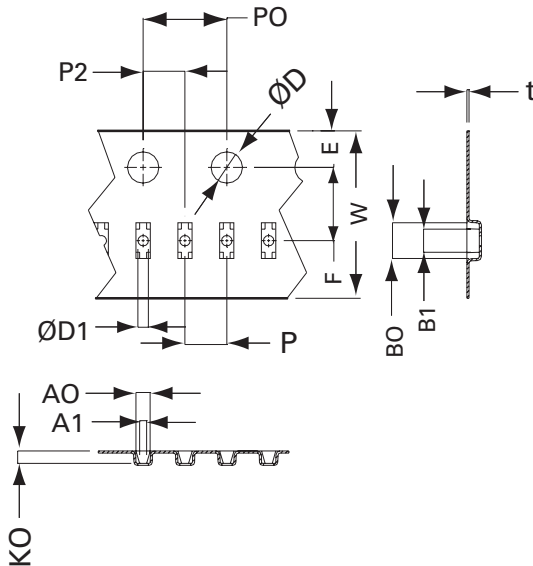

Symbol	Millimetres		Inches	
	Min	Max	Min	Max
E	1.65	1.85	0.064	0.072
F	3.45	3.55	0.135	0.139
D1	0.45	0.55	0.017	0.021
D	150	--	0.06	--
PO	3.90	4.10	0.153	0.161
10PO	40.0+/- 0.20		1.57+/-0.01	
W	7.90	8.20	0.311	0.322
PO	1.90	2.10	0.074	0.082
AO	0.63	0.73	0.024	0.028
A1	0.33 REF		0.01 REF	
BO	1.66	1.76	0.07	0.07
B1	1.10 REF		0.04 REF	
KO	0.54	0.64	0.021	0.025
t	--	0.21	--	0.008