

**ULTRA-SMALL BUILT-IN DELAY
HIGH-PRECISION VOLTAGE DETECTOR**
LR8809 SERIES
■ Introduction

The LR8809 Series is a series of high-precision voltage detectors with a built-in delay time generator of fixed time, developed using CMOS process. The detection voltage is fixed internally, with an accuracy of $\pm 2.0\%$. Internal oscillator and counter timer can delay the release signal without external parts, delay times 200 mS Two output forms, Nch pen-drain and CMOS output are available.

■ Application

- Memory battery back-up circuits
- Power-on reset circuits
- Power failure detection
- Power monitor for portable equipment such as notebook computers, digital cameras, PDA, and cellular phones.
- Constant voltage power monitors for cameras, video equipment and communication devices.
- Power monitor for microcomputers and reset for CPUs.

■ Features

- Ultra-low current consumption: $1.0\mu\text{A}@3.5\text{V}(\text{typ})$
- High-precision detection voltage: $\pm 2.0\%$
- Hysteresis characteristics: $-V_{\text{DET}} \times 5\%(\text{typ})$
- Operating voltage range: 0.95 V to 8.0 V
- Detection voltage: 1.5V to 6.0 V (0.1 V step)
- Delay time: 200 mS(typ)
- Output forms:
 - NMOS open-drain output (Active Low)
 - CMOS output (Active Low)

■ Ordering Information
LR8809 ①②③④

DESIGNATOR	SYMBOL	DESCRIPTION
①	C	CMOS
	N	Nch open drain
②③	Integer	Output Voltage(1.5V~6.0V) e.g. 3.0V= ②:3, ③:0
④	M/MA	Package: SOT23-3
	N/NA	Package: SOT343(SC-82)
	P	Package: SOT89-3
	T/TA	Package: TO-92
	E	Package: SOT23-6

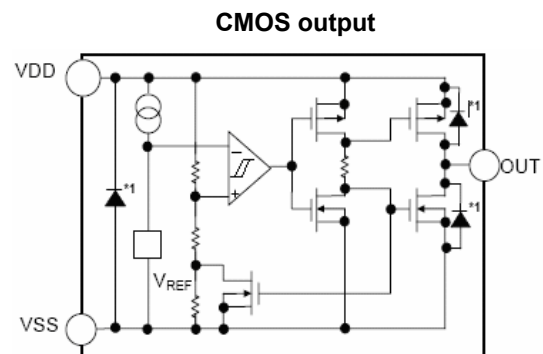
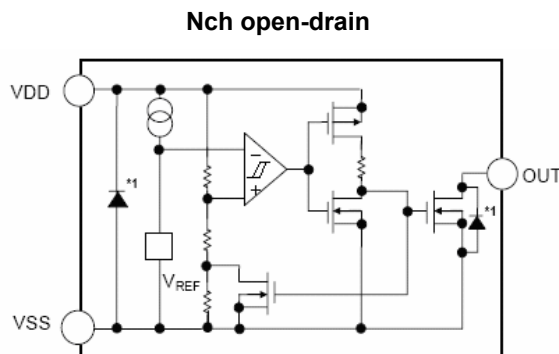
■ Block Diagrams

Note:*1-parasitic diode

■ Pin Configurations

Table 1 LR8809 Series (SOT-23-3)

PIN NO.	M	MA	Functions
1	V_{DD}	V_{DD}	Voltage input pin
2	V_{OUT}	-	Voltage detection output pin
	-	V_{SS}	GND pin
3	V_{SS}	-	GND pin
	-	V_{OUT}	Voltage detection output pin

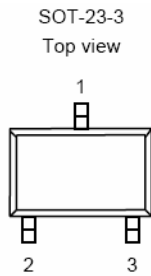

Table 2 LR8809 Series (SOT-89-3)

PIN NO	P	Functions
1	V_{OUT}	Voltage detection output pin
2	V_{DD}	Voltage input pin
3	V_{SS}	GND pin

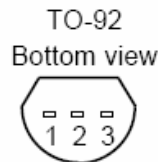

Table 3 LR8809 Series (TO-92)

PIN NO	T	TA	Functions
1	V_{OUT}	-	Voltage detection output pin
	-	V_{DD}	Voltage input pin
2	V_{DD}	-	Voltage input pin
	-	V_{SS}	GND pin
3	V_{SS}	-	GND pin
	-	V_{OUT}	Voltage detection output pin

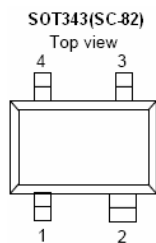
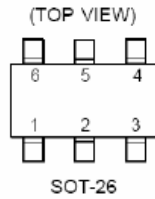

Table 4 LR8809 Series (SOT343)

PIN NO	N	NA	Functions
1	V_{OUT}	-	Voltage detection output pin
	-	V_{DD}	Voltage input pin
2	V_{DD}	-	Voltage input pin
		V_{SS}	GND pin
3	NC	-	No Connection
4	V_{SS}	-	GND pin
	-	V_{OUT}	Voltage detection output pin

Table 5 LR8809 Series (SOT23-6)



PIN NO	E	Functions
1	NC	No Connection
2	VSS	GND pin
3	VOUT	Voltage detection output pin
4	VDD	Voltage input pin
5	NC	No Connection
6	NC	No Connection

■ Absolute Maximum Ratings

(Ta=25°C unless otherwise specified)

Item	Symbol	Absolute maximum ratings	Unit	
Power supply voltage	V _{DD}	V _{SS} -0.3 ~ V _{SS} +10	V	
Output voltage	V _{OUT}	V _{SS} -0.3 ~ V _{SS} +10	V	
Power dissipation	SOT-23-3	PD	250	mW
	SOT-89		500	mW
	TO-92		500	mW
	SOT343		250	mW
Operating ambient temperature	Topr	-40 ~ +85	°C	
Storage temperature	Tstg	-40 ~ +125	°C	

■ Electrical Characteristics

(Ta=25°C unless otherwise specified)

Item	Symbol	Condition	Min.	Typ.	Max.	Unit	
Detection voltage*1	-V _{DET}	—	-V _{DET(S)} ×0.98	-V _{DET(S)}	-V _{DET(S)} ×1.02	V	
Hysteresis width	V _{HYS}	—	0.02× -V _{DET(S)}	0.05× -V _{DET(S)}	0.08× -V _{DET(S)}	V	
Current consumption	I _{SS}	V _{DD} = -V _{DET} + 0.5V	LR8809C/N20~26	—	1.0	2.0	uA
			LR8809 C/N 26~39	—	1.2	2.5	uA
			LR8809 C/N 39~60	—	1.5	3.0	uA
Operating voltage	V _{DD}	—	0.95	—	8	V	

Output current	I_{OUT}	NMOS: $V_{OUT} = 0.5\text{ V}$ $V_{DD} = -V_{DET} - 0.5\text{ V}$	LR8809 C/N 20~26	3.0	13.0	—	mA
			LR8809 C/N 26~39	3.0	15.0	—	mA
			LR8809 C/N 39~60	3.0	18.0	—	mA
		PMOS: $V_{DD} - V_{OUT} = 0.5\text{ V}$ $V_{DD} = -V_{DET} + 0.5\text{ V}$	LR8809 C/N 20~26	1.5	4.0	—	mA
			LR8809 C/N 26~39	1.5	6.0	—	mA
			LR8809 C/N 39~60	1.5	8.0	—	mA
Leakage current	I_{LEAK}	Only for NMOS open-drain output products, $V_{DD} = 8.0\text{ V}$, $V_{OUT} = 8.0\text{ V}$			—	0.1	uA
temperature coefficient		$T_a = -40^\circ\text{C} \sim +85^\circ\text{C}$		—	± 120	± 360	ppm/ °C
Delay time	T_D				200		mS

*1. $-V_{DET}$: Actual detection voltage value, $-V_{DET}(S)$: Specified detection voltage value

■ Functional Description

1. When a voltage higher than the release voltage ($+V_{DET}$) is applied to the voltage input pin (V_{DD}), the voltage will gradually fall..When a voltage higher than the detect voltage ($-V_{DET}$) is applied to V_{DD} , output (V_{OUT}) will be equal to the input at V_{DD} .

Note that high impedance exists at V_{OUT} with the N-channel open drain configuration. If the pin is pulled up, V_{OUT} will be equal to the pull up voltage.

2. When V_{DD} falls below $-V_{DET}$, V_{OUT} will be equal to the ground voltage (V_{SS}) level (detect state).

Note that this also applies to N-channel open drain configurations.

3. When V_{DD} falls to a level below that of the minimum operating voltage (V_{MIN}) output will become unstable.

Because the output pin is generally pulled up with N-channel open drain configurations, output will be equal to pull up voltage.

4. When V_{DD} rises above the V_{SS} level (excepting levels lower than minimum operating voltage), V_{OUT} will be equal to V_{SS} until V_{DD} reaches the $+V_{DET}$ level.

5. Although V_{DD} will rise to a level higher than $+V_{DET}$, V_{OUT} maintains ground voltage level via the delay circuit.

6. Following transient delay time, V_{DD} will be output at V_{OUT} .

Note that high impedance exists with the N-channel open drain configuration and that voltage will be dependent on pull up.

Notes :

1. The difference between $-V_{DET}$ and $+V_{DET}$ represents the hysteresis range.

2. Propagation delay time (t_D) represents the time it takes for V_{DD} to appear at V_{OUT} once the said voltage has exceeded the $+V_{DET}$ level.

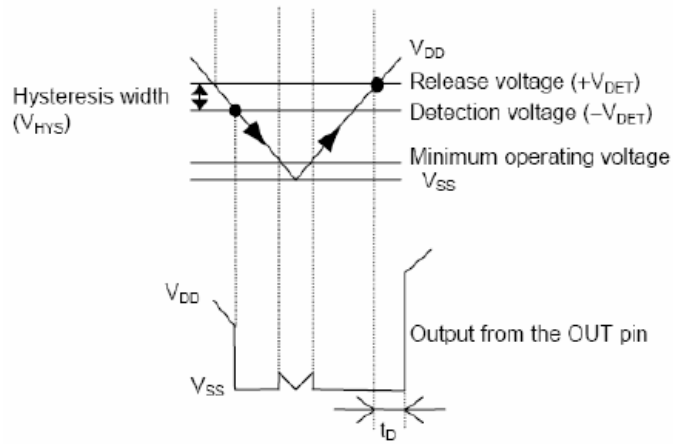

■ Standard Circuits

1. CMOS output:

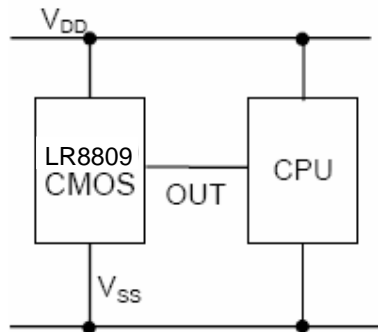

2. Nch open-drain

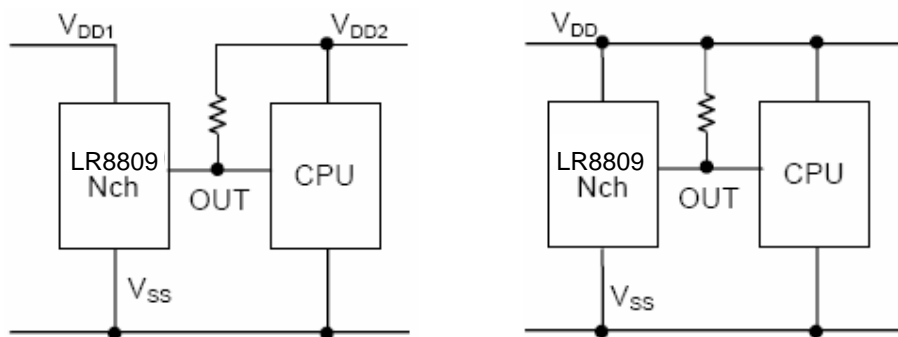

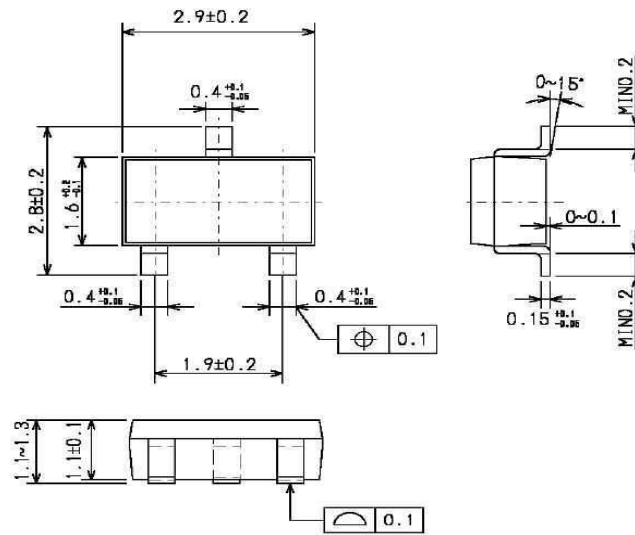
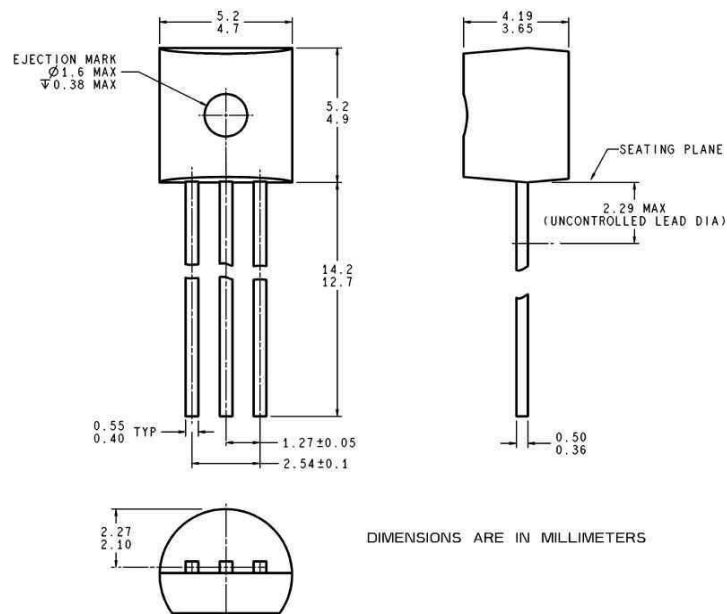
■ Package information
● SOT-23-3

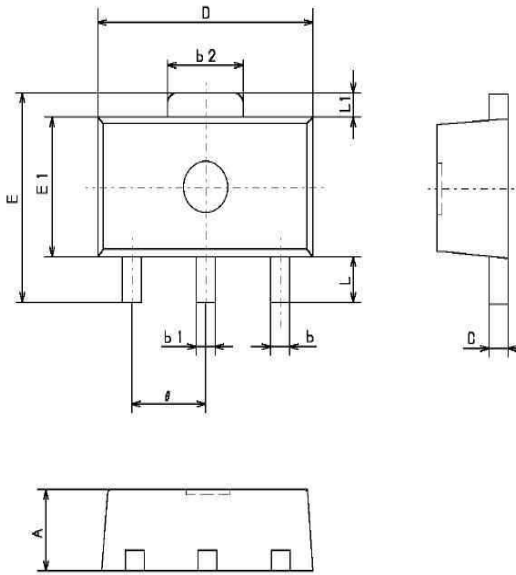
● TO-92

• SOT-89

Symbols	Dimensions in millimeters		
	Min	Nom	Max
A	1.40	1.50	1.60
b	0.36	0.42	0.48
b1	0.41	0.47	0.53
b2	1.40	1.60	1.75
C	0.38	0.40	0.43
D	4.40	4.50	4.60
E	—	—	4.25
E1	2.40	2.50	2.60
θ	1.40	1.50	1.60
L	1.80	—	—
L1	—	0.40	—

• SOT343 (SC-82)
