

VHF/UHF WIDE BAND AMPLIFIER APPLICATION.

FEATURES

- Low Noise Figure, High Gain.
- $NF=1.2dB$, $|S_{21e}|^2=13dB$ ($f=1GHz$).

MAXIMUM RATING (Ta=25°C)

CHARACTERISTIC	SYMBOL	RATING	UNIT
Collector-Base Voltage	V_{CBO}	20	V
Collector-Emitter Voltage	V_{CEO}	10	V
Emitter-Base Voltage	V_{EBO}	1.5	V
Collector Current	I_C	65	mA
Collector Power Dissipation	P_C	150	mW
Junction Temperature	T_j	150	°C
Storage Temperature Range	T_{stg}	-55~150	°C

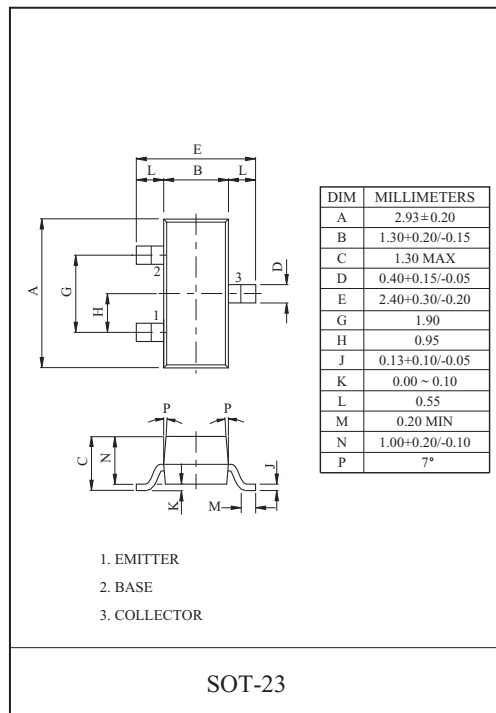

Marking

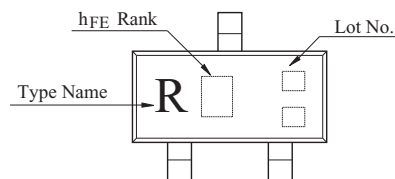

ELECTRICAL CHARACTERISTICS (Ta=25°C)

CHARACTERISTIC	SYMBOL	TEST CONDITION	MIN.	TYP.	MAX.	UNIT
Collector Cut-off Current	I_{CBO}	$V_{CB}=10V, I_E=0$	-	-	1	μA
Emitter Cut-off Current	I_{EBO}	$V_{EB}=1V, I_C=0$	-	-	1	μA
DC Current Gain	h_{FE} (Note1)	$V_{CE}=8V, I_C=20mA$	50	-	250	
Reverse Transfer Capacitance	C_{re}	$V_{CB}=10V, I_E=0, f=1MHz$ (Note2)	-	0.35	0.9	pF
Transition Frequency	f_T	$V_{CE}=8V, I_C=20mA$	-	9	-	GHz
Insertion Gain	$ S_{21e} ^2$	$V_{CE}=8V, I_C=20mA, f=1GHz$	11	13	-	dB
Noise Figure	NF	$V_{CE}=8V, I_C=7mA, f=1GHz$	-	1.2	2.5	dB

Note 1 : h_{FE} Classification L:50~100, M:80~160, N:125~250.

Note 2 : C_{re} is measured by 3 terminal method with capacitance bridge.

KTC3790S

TYPICAL CHARACTERISTICS

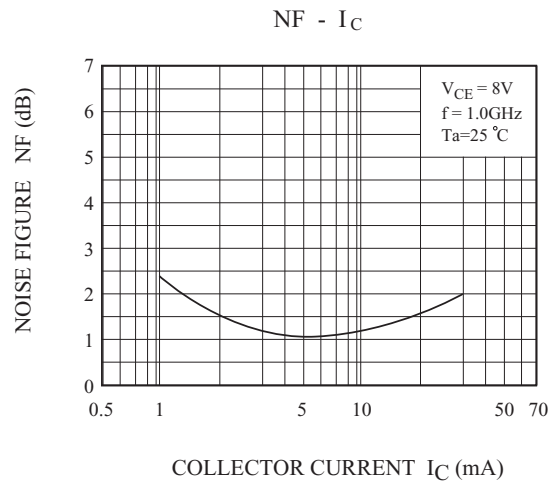
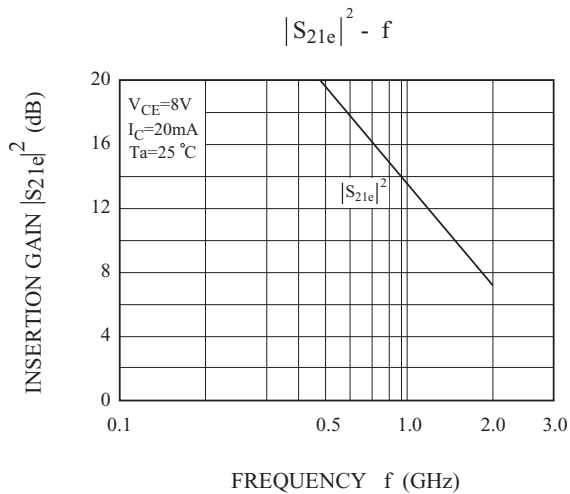
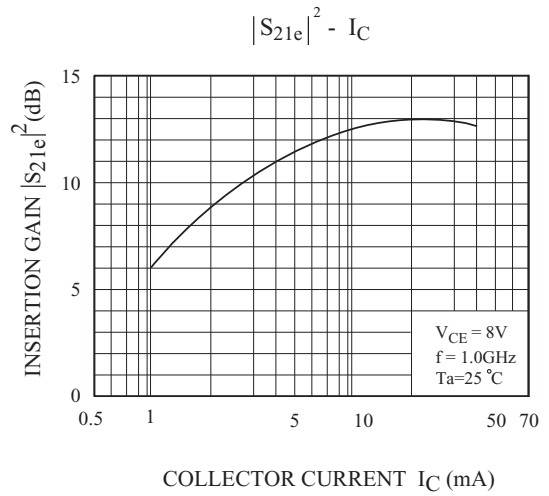
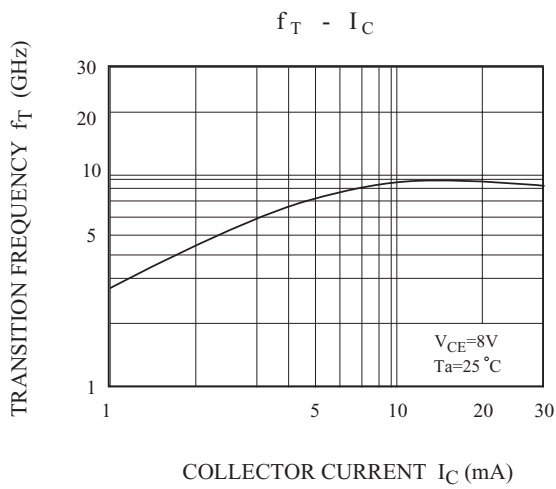
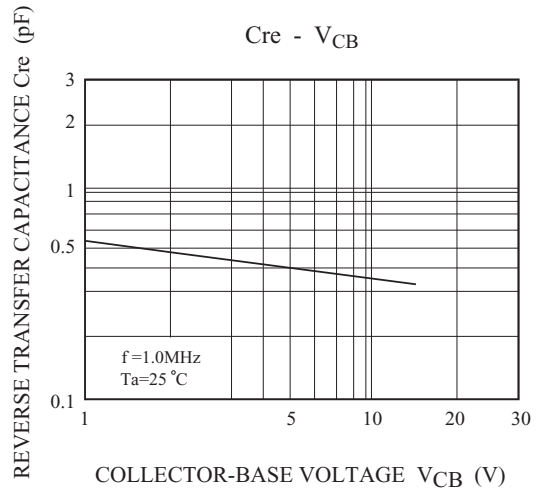
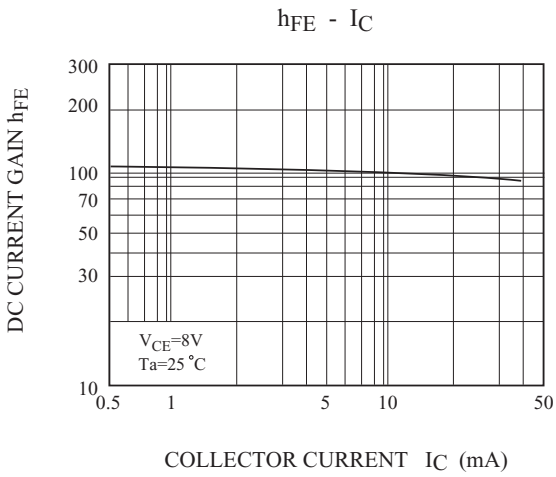

KTC3790S

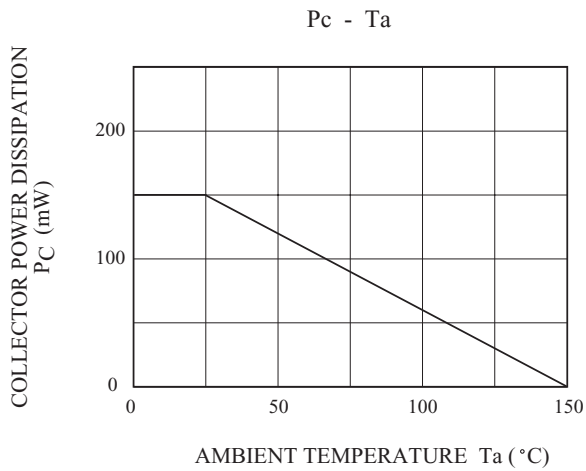

S-PARAMETER

($V_{CE} = 8V$, $I_C = 5mA$, $Z_O = 50 \Omega$, $T_a = 25^\circ C$)

Frequency MHz	S ₁₁		S ₂₁		S ₂₁		S ₂₂	
	Mag.	Ang.	Mag.	Ang.	Mag.	Ang.	Mag.	Ang.
200	0.728	-45.3	12.107	138.7	0.036	66.2	0.825	-21.6
400	0.490	-74.5	8.097	114.2	0.065	61.6	0.675	-26.6
600	0.343	-93.2	6.260	102.3	0.079	61.6	0.582	-29.0
800	0.253	-110.1	4.623	90.1	0.090	61.2	0.529	-28.6
1000	0.202	-131.1	4.004	83.6	0.101	61.3	0.500	-30.1
1200	0.176	-148.9	3.250	75.8	0.125	60.8	0.470	-31.4
1400	0.176	-162.8	3.021	69.4	0.144	60.0	0.448	-33.4
1600	0.179	173.9	2.575	63.4	0.160	59.8	0.427	-34.8
1800	0.186	163.3	2.520	58.9	0.188	59.1	0.406	-37.5
2000	0.211	151.1	2.183	53.4	0.202	58.9	0.386	-44.5

($V_{CE} = 8V$, $I_C = 20mA$, $Z_O = 50 \Omega$, $T_a = 25^\circ C$)

Frequency MHz	S ₁₁		S ₂₁		S ₂₁		S ₂₂	
	Mag.	Ang.	Mag.	Ang.	Mag.	Ang.	Mag.	Ang.
200	0.366	-66.8	19.757	116.9	0.033	62.6	0.587	-22.5
400	0.194	-88.9	10.502	98.8	0.055	70.6	0.485	-23.8
600	0.124	-104.3	7.591	91.1	0.072	74.6	0.453	-24.3
800	0.077	-132.0	5.446	82.0	0.095	73.2	0.419	-23.2
1000	0.063	-156.4	4.653	77.6	0.107	72.1	0.413	-24.2
1200	0.065	179.5	3.754	71.6	0.135	72.1	0.392	-26.4
1400	0.074	168.0	3.460	66.5	0.164	70.1	0.369	-29.9
1600	0.108	147.0	2.934	61.9	0.178	69.6	0.347	-32.2
1800	0.116	137.6	2.870	58.2	0.205	66.3	0.333	-34.3
2000	0.134	131.2	2.479	53.4	0.221	64.0	0.312	-42.1

KTC3790S

S_{11e}
 V_{CE}=8V
 I_C=5mA
 T_a=25°C
 (UNIT : Ω)

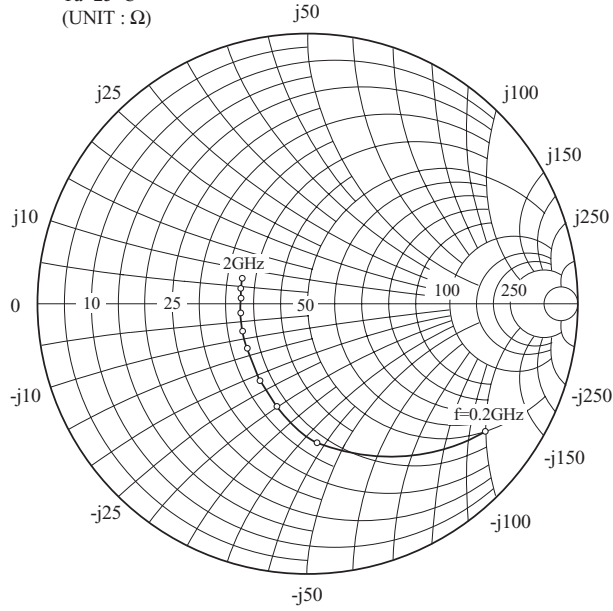

S_{12e}
 V_{CE}=8V
 I_C=5mA
 T_a=25°C

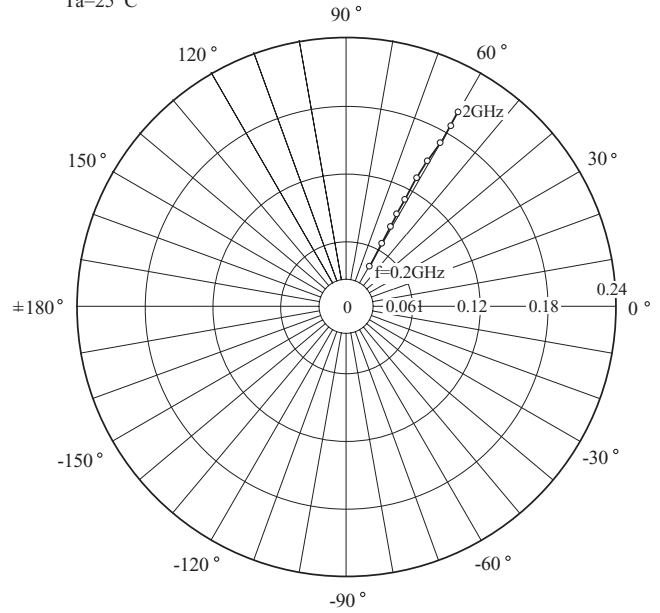

S_{21e}
 V_{CE}=8V
 I_C=5mA
 T_a=25°C

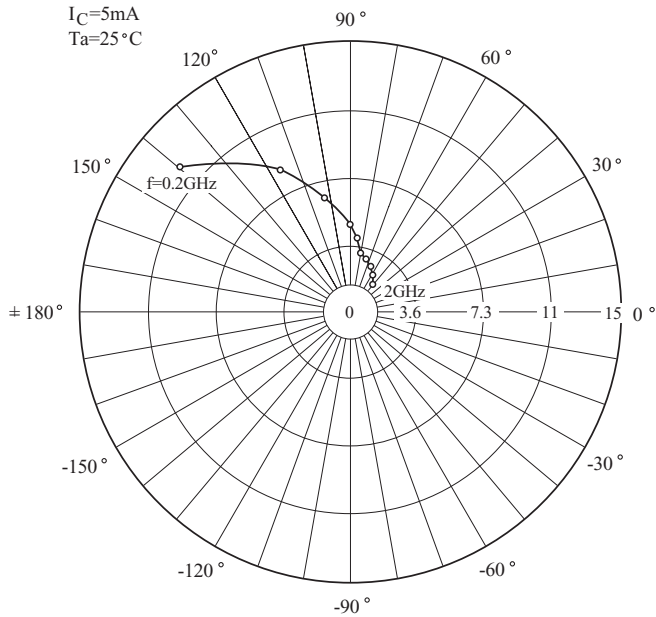

S_{22e}
 V_{CE}=8V
 I_C=5mA
 T_a=25°C
 (UNIT : Ω)

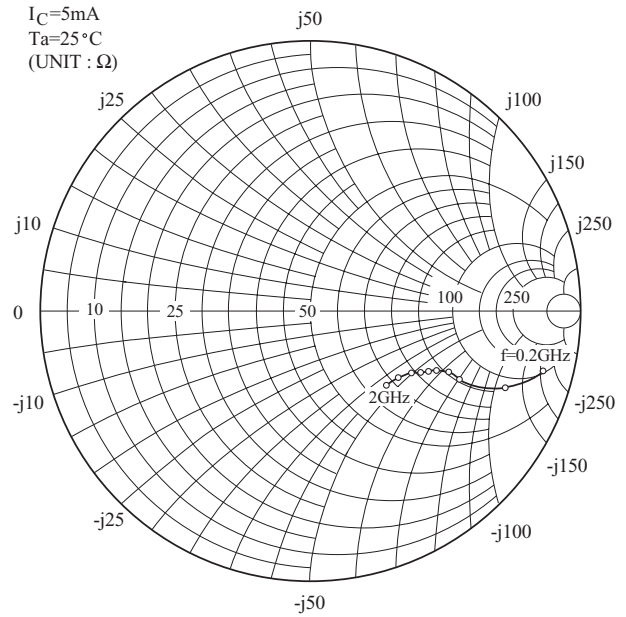

KTC3790S

S_{11e}
 $V_{CE}=8V$
 $I_C=20mA$
 $T_a=25^\circ C$
 (UNIT : Ω)

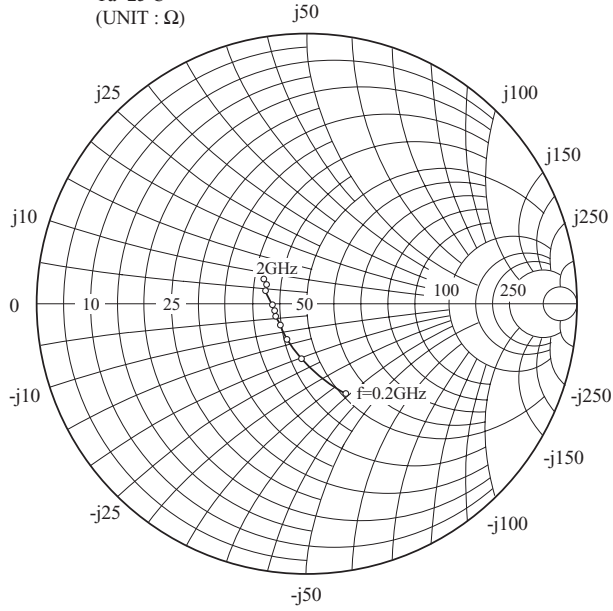

S_{12e}
 $V_{CE}=8V$
 $I_C=20mA$
 $T_a=25^\circ C$

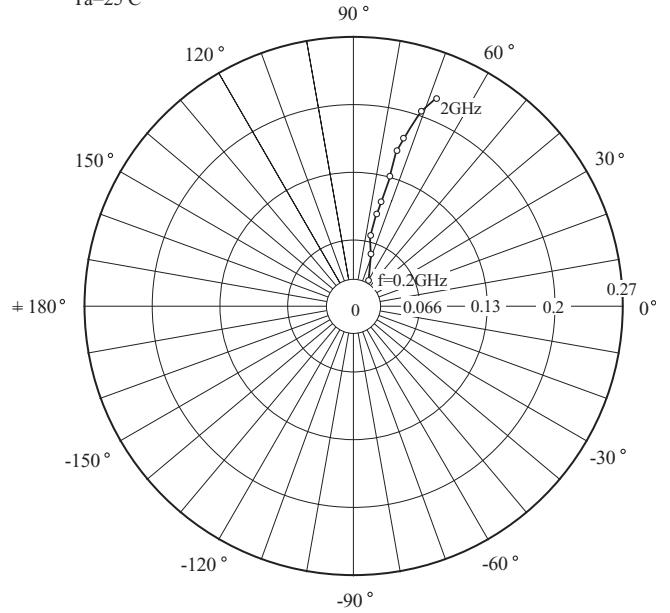

S_{21e}
 $V_{CE}=8V$
 $I_C=20mA$
 $T_a=25^\circ C$

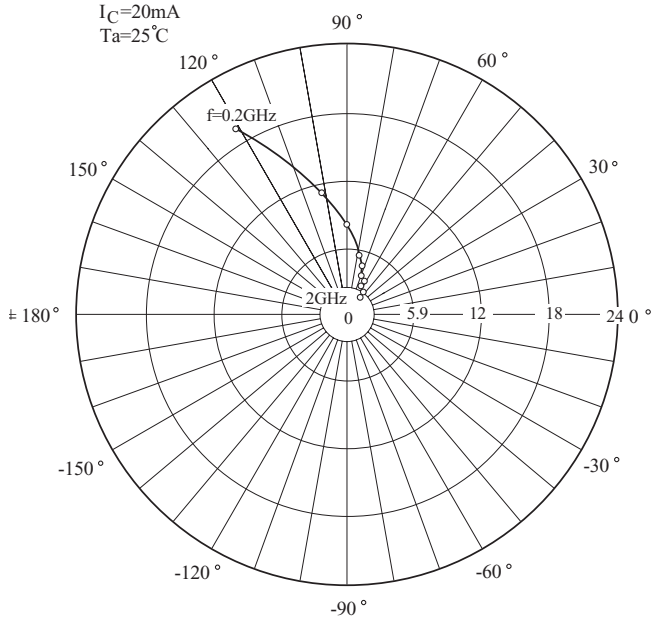

S_{22e}
 $V_{CE}=8V$
 $I_C=20mA$
 $T_a=25^\circ C$
 (UNIT : Ω)

