

500mA POWER LOW DROPOUT REGULATOR

The KR52SXXXM/F is an efficient linear voltage regulator with very low dropout voltage(Typically 10mV at light loads and 350mV at 500mA)

The KR52SXXXM/F can be enabled, or shut down by a CMOS or TTL compatible signal. When disabled, power consumption drops nearly to zero. Dropout ground current is minimized to help prolong battery life. Other key features include reversed battery protection, current limiting, over temperature shutdown, and low noise performance with an ultra-low-noise option

FEATURES

- High Output Voltage Accuracy : 1%
- Low Quiescent Current : $I_{Q(OFF)} = 3 \mu A$
- Very Low Ground Current : 4.0mA($I_{OUT} = 300mA$)
- Low Dropout Voltage : 350mV($I_{OUT} = 500mA$)
- Built-in ON/OFF control Terminal
- Built -in Over Current , Over Heat Protection Function
- Reverse-Battery Protection

APPLICATIONS

- Laptop, notebook, and palmtop computers
- Cellular telephones and battery-powered equipment
- Consumer and personal electronics
- PC Card VCC and VPP regulation and switching
- SMPS post-regulator/dc-to-dc modules
- High-efficiency linear power supplies

LINE-UP

V_{OUT} (V)	TSV		SOT-89-5	
	ITEM	MARKING	ITEM	MARKING
1.8	KR52S018M	C18	* KR52S018F	E1
2.5	KR52S025M	C25	* KR52S025F	E2
2.6	KR52S026M	C26	* KR52S026F	E3
2.7	KR52S027M	C27	* KR52S027F	E4
2.8	KR52S028M	C28	* KR52S028F	E5
2.85	KR52S285M	C2J	* KR52S285F	E6
2.9	KR52S029M	C29	* KR52S029F	E7
3.0	KR52S030M	C30	* KR52S030F	E8
3.1	KR52S031M	C31	* KR52S031F	E9
3.3	KR52S033M	C33	* KR52S033F	E0

* : Under development

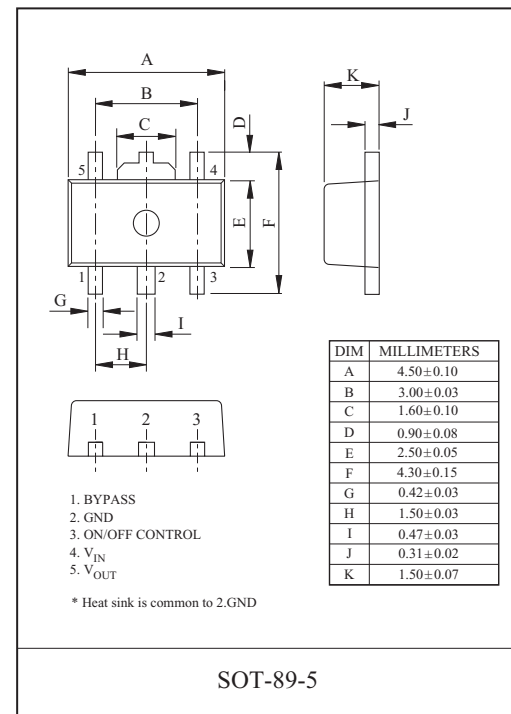
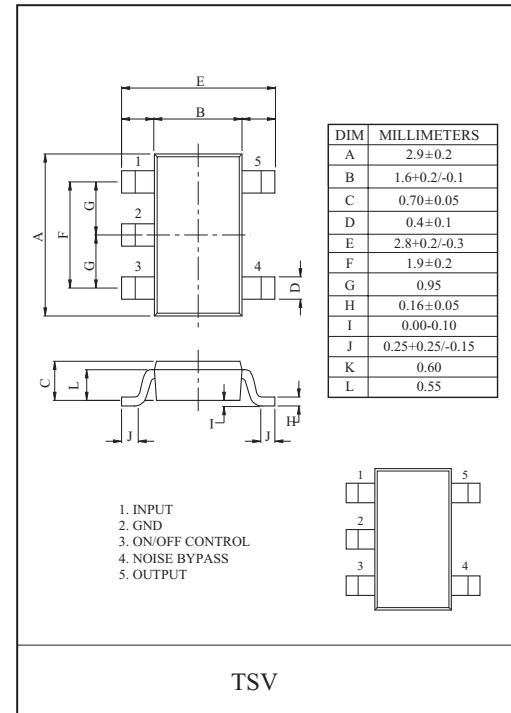

KR52S018M/F ~ KR52S033M/F

MARKING

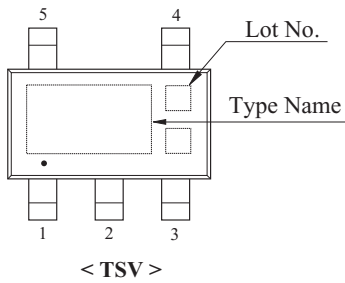

PIN DESCRIPTIONS

PIN NO.	NAME	FUNCTION
1	V_{IN}	Supply Input
2	GND	Ground
3	ON/OFF Control	Enable/Shutdown (Input):CMOS compatible input. Logic high = Enable, Logic low or open = Shutdown
4	Bypass	Reference Bypass : Connect external 470pF capacitor to GND to reduce output noise. May be left open
5	V_{OUT}	Regulator Output

MARKING

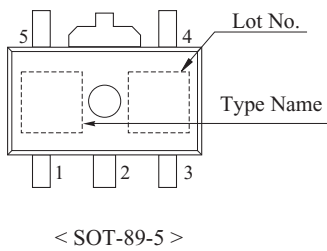

PIN DESCRIPTIONS

PIN NO.	NAME	FUNCTION
1	Bypass	Reference Bypass : Connect external 470pF capacitor to GND to reduce output
2	GND	Ground
3	ON/OFF Control	Enable/Shutdown (Input):CMOS compatible input. Logic high = Enable, Logic low or open = Shutdown
4	V_{IN}	Supply Input
5	V_{OUT}	Regulator Output

Fig. 1 BLOCK DIAGRAM

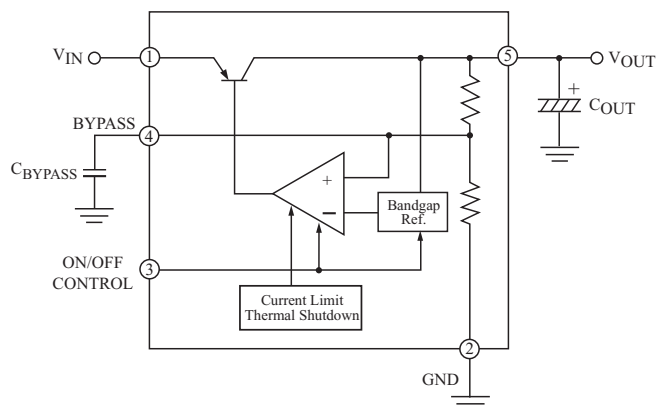
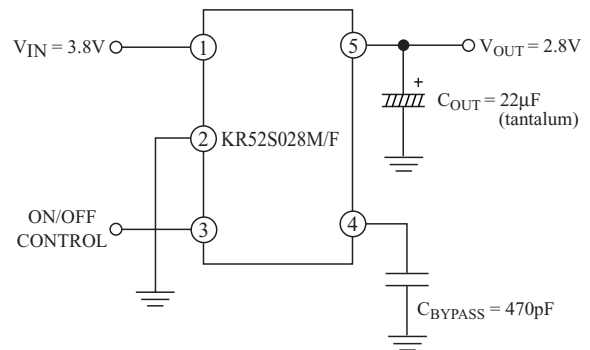

Fig. 2 TEST CIRCUIT / APPLICATION CIRCUIT



KR52S018M/F ~ KR52S033M/F

MAXIMUM RATINGS (Ta=25 °C)

CHARACTERISTIC	SYMBOL	RATING	UNIT
Supply Input Voltage	V _{IN}	16	V
ON/OFF Control Voltage	V _C	5	V
Output Current	I _{OUT}	500	mA
Power Dissipation (Note)	(TSV)	900	mW
	(SOT-89-5)		
Operating Junction Temperature	Topr	-40~125	°C
Storage Temperature	Tstg	-55~150	°C

ELECTRICAL CHARACTERISTICS

(Unless otherwise specified, V_{IN}=V_{OUT}+1V, I_{OUT}=100μA, C_{OUT}=4.7μF, T_j=25 °C)

CHARACTERISTIC		SYMBOL	TEST CONDITION	MIN.	TYP.	MAX.	UNIT
Output Voltage	KR52S018M/F	V _{OUT}	V _{IN} =V _{OUT} +1V	1.782	1.8	1.818	V
	KR52S025M/F			2.475	2.5	2.525	
	KR52S026M/F			2.574	2.6	2.626	
	KR52S027M/F			2.673	2.7	2.727	
	KR52S028M/F			2.772	2.8	2.828	
	KR52S285M/F			2.8215	2.85	2.8785	
	KR52S029M/F			2.871	2.9	2.929	
	KR52S030M/F			2.97	3.0	3.03	
	KR52S031M/F			3.069	3.1	3.131	
	KR52S033M/F			3.267	3.3	3.333	
Load Regulation	Reg Load		100μA ≤ I _O ≤ 0.5A	-	-	2.0	%
Line Regulation	Reg Line		V _{IN} =V _{OUT} +1V~12V	-	-	0.05	%/V
Dropout Voltage	V _{D1}		I _{OUT} =100μA	-	10	60	mV
	V _{D2}		I _{OUT} =50mA	-	115	175	mV
	V _{D3}		I _{OUT} =150mA	-	175	300	mV
	V _{D5}		I _{OUT} =500mA	-	350	500	mV
Ripple Rejection	RR		f=120Hz	-	75	-	dB
Output Noise Voltage	V _{NO}		I _{OUT} =50mA, C _{OUT} =2.2μF C _{BYPASS} =470pF	-	30	-	μVrms
Output ON-state voltage for control	V _{C(ON)}		-	2.0	-	-	V
Output ON-state current for control	I _{C(ON)}		V _C =2.0V	-	5	20	μA
Output OFF-state voltage for control	V _{C(OFF)}		-	-	-	0.4	V
Output OFF-state current for control	I _{C(OFF)}		V _C =0.4V	-	0.01	1	μA
Quiescent Current	I _{Q1}		V _C =3V, I _{OUT} =100μA	-	80	130	μA
	I _{Q2}		V _C =3V, I _{OUT} =50mA	-	350	650	μA
	I _{Q3}		V _C =3V, I _{OUT} =150mA	-	1.8	2.5	mA
	I _{Q4}		V _C =3V, I _{OUT} =500mA	-	12	20	mA
Quiescent Current (OFF Mode)	I _{Q(OFF1)}		V _C =0.4V	-	0.05	3	μA
	I _{Q(OFF2)}		V _C =0.18V	-	0.10	8	
Short Circuit Current	I _{SC}		V _O =0A	0.51	-	-	A

KR52S018M/F ~ KR52S033M/F

Fig. 1 $I_{GND} - I_O$

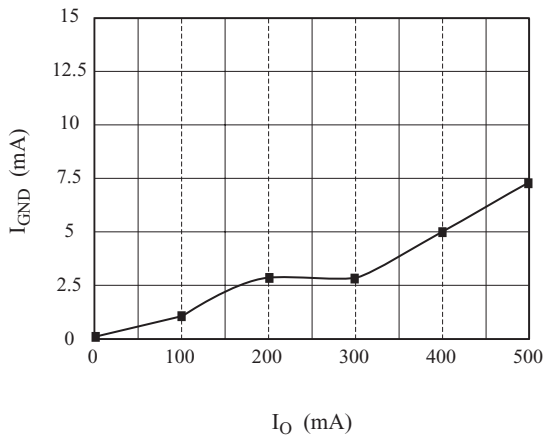

Fig. 2 $I_q - V_{IN}$

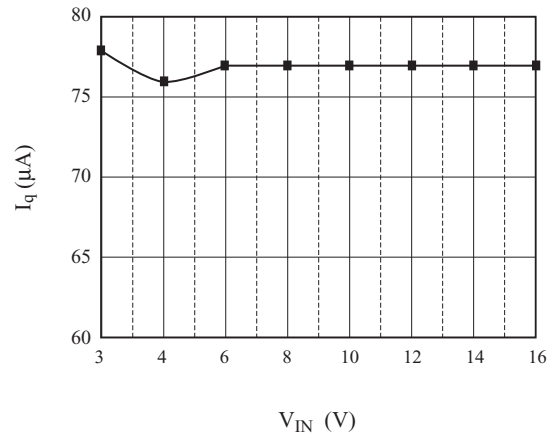

Fig. 3 $V_D - I_{OUT}$

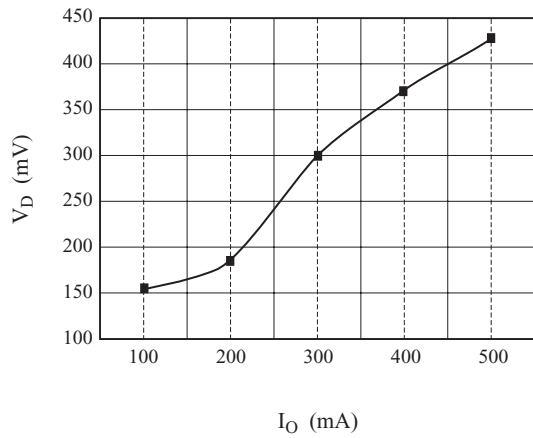

Fig. 4 $V_{OUT} - V_{IN}$

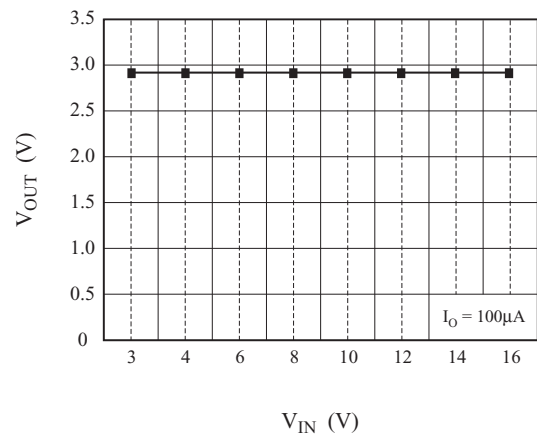

Fig. 5 $V_{OUT} - I_{OUT}$

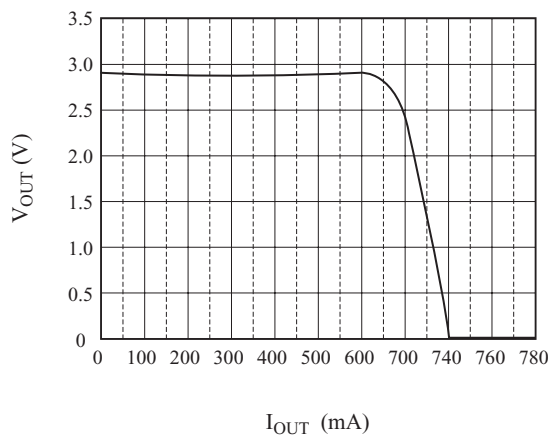
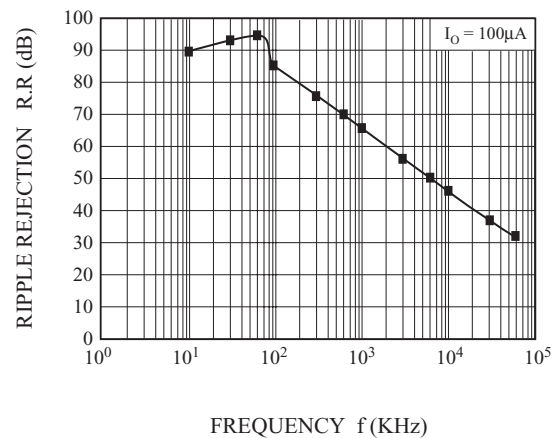

Fig. 6 $f - R.R$



KR52S018M/F ~ KR52S033M/F

Fig. 7 V_{OUT} - TEMP

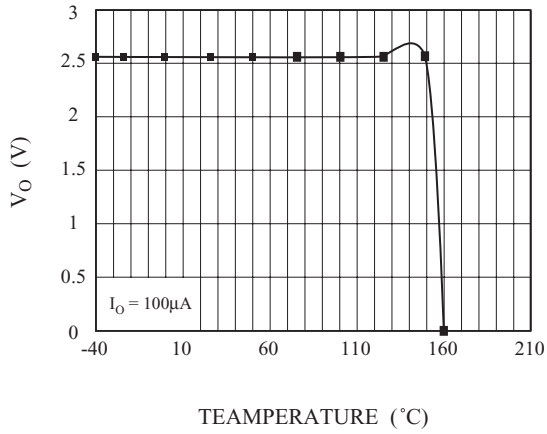

Fig. 8 V_{ENH} - TEMP

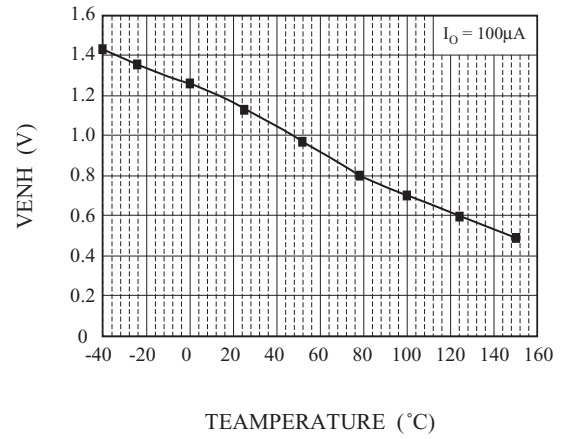

Fig. 9 I_{GND} - TEMP

