

300mA POWER LOW DROPOUT REGULATOR

The KR32SXXXM/F is an efficient linear voltage regulator with very low dropout voltage (Typically 10mV at light loads and 250mV at 300mA)

The KR32SXXXM/F can be enabled, or shut down by a CMOS or TTL compatible signal. When disabled, power consumption drops nearly to zero. Dropout ground current is minimized to help prolong battery life. Other key features include reversed battery protection, current limiting, over temperature shutdown, and low noise performance with an ultra-low-noise option

FEATURES

- High output voltage accuracy : 1%
- Low quiescent current : $I_{Q(OFF)} = 3\mu A$
- Very low ground current : 1.8mA ($I_{OUT}=150mA$)
- Low dropout voltage : 250mV ($I_{OUT}=300mA$)
- Built-in ON/OFF control terminal
- Built-in over current , Over heat protection function
- Reverse-battery protection

APPLICATIONS

- Laptop, notebook, and palmtop computers
- Cellular telephones and battery-powered equipment
- Consumer and personal electronics
- PC Card V_{CC} and VPP regulation and switching
- SMPS post-regulator/dc-to-dc modules
- High-efficiency linear power supplies

LINE-UP

V_{OUT} (V)	TSV		SOT-89-5	
	ITEM	MARKING	ITEM	MARKING
1.8	KR32S018M	B18	KR32S018F	D1
2.5	KR32S025M	B25	KR32S025F	D2
2.6	KR32S026M	B26	KR32S026F	D3
2.7	KR32S027M	B27	KR32S027F	D4
2.8	KR32S028M	B28	KR32S028F	D5
2.85	KR32S285M	B2J	KR32S285F	D6
2.9	KR32S029M	B29	KR32S029F	D7
3.0	KR32S030M	B30	KR32S030F	D8
3.1	KR32S031M	B31	KR32S031F	D9
3.3	KR32S033M	B33	KR32S033F	D0

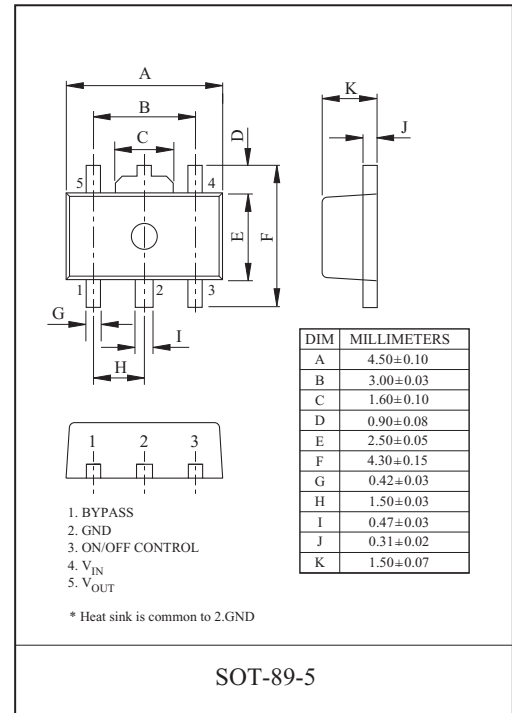
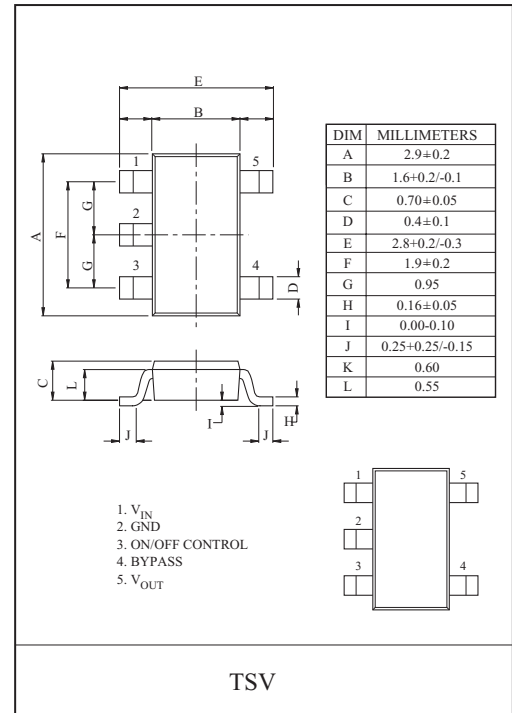

KR32S018M/F~KR32S033M/F

MARKING

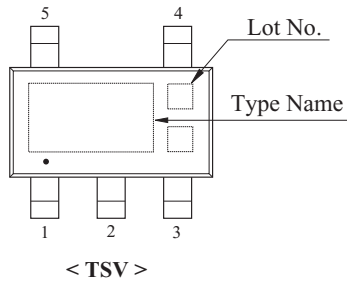

PIN DESCRIPTIONS

PIN NO.	NAME	FUNCTION
1	V_{IN}	Supply Input
2	GND	Ground
3	ON/OFF Control	Enable/Shutdown (Input):CMOS compatible input. Logic high = Enable, Logic low or open = Shutdown
4	Bypass	Reference Bypass : Connect external 470pF capacitor to GND to reduce output noise. May be left open
5	V_{OUT}	Regulator Output

MARKING

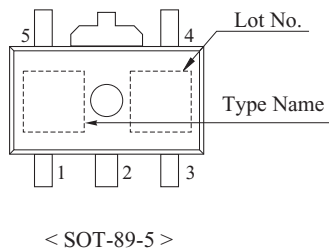

PIN DESCRIPTIONS

PIN NO.	NAME	FUNCTION
1	Bypass	Reference Bypass : Connect external 470pF capacitor to GND to reduce output
2	GND	Ground
3	ON/OFF Control	Enable/Shutdown (Input):CMOS compatible input. Logic high = Enable, Logic low or open = Shutdown
4	V_{IN}	Supply Input
5	V_{OUT}	Regulator Output

Fig. 1 BLOCK DIAGRAM

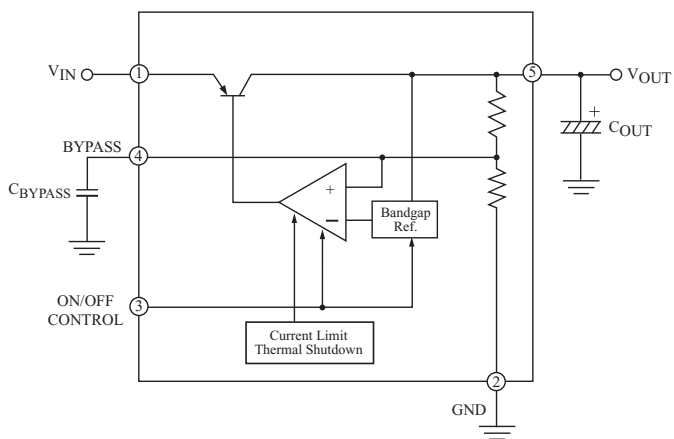
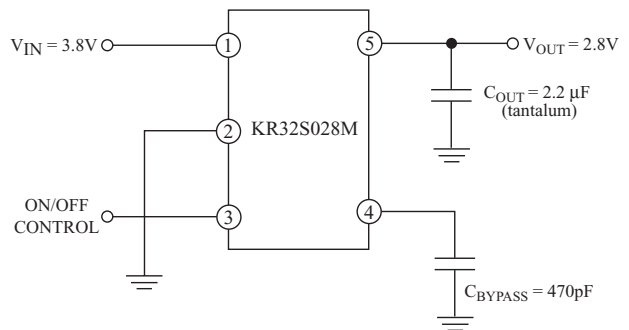

Fig. 2 TEST CIRCUIT / APPLICATION CIRCUIT



KR32S018M/F~KR32S033M/F

MAXIMUM RATINGS (Ta=25 °C)

CHARACTERISTIC		SYMBOL	RATING	UNIT
Supply Input Voltage		V _{IN}	14	V
ON/OFF Control Voltage		V _C	5	V
Output Current		I _{OUT}	300	mA
Power Dissipation (Note)	TSV	P _D	900	mW
	SOT-89-5			
Junction Temperature		T _j	150	°C
Operating Junction Temperature		T _{opr}	-40~125	°C
Storage Temperature		T _{stg}	-55~150	°C

Note) Package mounted on a ceramic board. (600m² × 0.8m)

ELECTRICAL CHARACTERISTICS

(Unless otherwise specified, V_{IN}=V_{OUT}+1V, I_{OUT}=100μA, C_{OUT}=4.7μF, T_j=25 °C)

CHARACTERISTIC		SYMBOL	TEST CONDITION	MIN.	TYP.	MAX.	UNIT
Output Voltage	KR32S018M/F	V _{OUT}	V _{IN} =V _{OUT} +1V	1.782	1.8	1.818	V
	KR32S025M/F			2.475	2.5	2.525	
	KR32S026M/F			2.574	2.6	2.626	
	KR32S027M/F			2.673	2.7	2.727	
	KR32S028M/F			2.772	2.8	2.828	
	KR32S285M/F			2.8215	2.85	2.8785	
	KR32S029M/F			2.871	2.9	2.929	
	KR32S030M/F			2.97	3.0	3.03	
	KR32S031M/F			3.069	3.1	3.131	
	KR32S033M/F			3.267	3.3	3.333	
Load Regulation		Reg Load	I _o =100μA~300mA	-	0.05	0.7	%
Line Regulation		Reg Line	V _{IN} =V _{OUT} +1V~10V	-	0.009	0.05	%/V
Dropout Voltage		V _{D-1}	I _{OUT} =100μA	-	10	60	mV
		V _{D-2}	I _{OUT} =50mA	-	115	175	mV
		V _{D-3}	I _{OUT} =150mA	-	175	300	mV
		V _{D-4}	I _{OUT} =300mA	-	250	400	mV
Temperature Coefficient of output voltage		TCV _o	T _j =-40 ~ 125 °C	-	40	80	ppm/°C
Ripple Rejection		RR	f=120Hz	-	75	-	dB
Output Noise Voltage		V _{NO}	I _{OUT} =50mA, C _{OUT} =2.2μF, C _{BYPASS} =470pF	-	30	-	μVrms
Output ON-state voltage for control		V _{C(ON)}	-	2.0	-	-	V
Output ON-state current for control		I _{C(ON)}	V _C =2.0V	2	5	20	μA
Output OFF-state voltage for control		V _{C(OFF)}	-	-	-	0.4	V
Output OFF-state current for control		I _{C(OFF-1)}	V _C =0.4V	-	0.01	-1	μA
		I _{C(OFF-2)}	V _C =0.18V	-	0.01	-2	μA
Quiescent Current		I _{Q1}	V _C =3V, I _{OUT} =100μA	-	80	130	μA
		I _{Q2}	V _C =3V, I _{OUT} =50mA	-	350	650	μA
		I _{Q3}	V _C =3V, I _{OUT} =150mA	-	1.8	2.5	mA
		I _{Q4}	V _C =3V, I _{OUT} =300mA	-	4.0	5.5	mA
Quiescent Current (OFF Mode)		I _{Q(OFF-1)}	V _C =0.4V	-	0.05	3	μA
		I _{Q(OFF-2)}	V _C =0.18V	-	0.10	8	

KR32S018M/F~KR32S033M/F

f_{IN} - R.R (1)

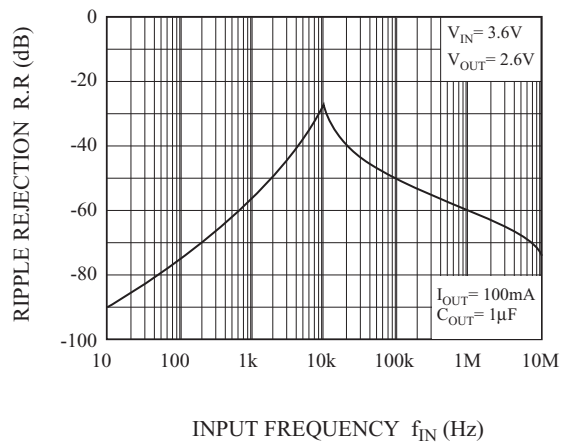

f_{IN} - R.R (2)

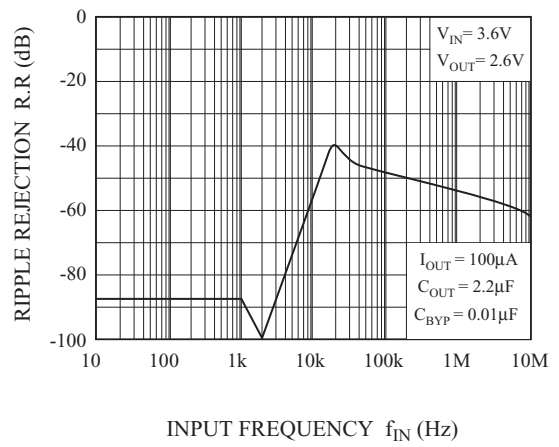

f_{IN} - R.R (3)

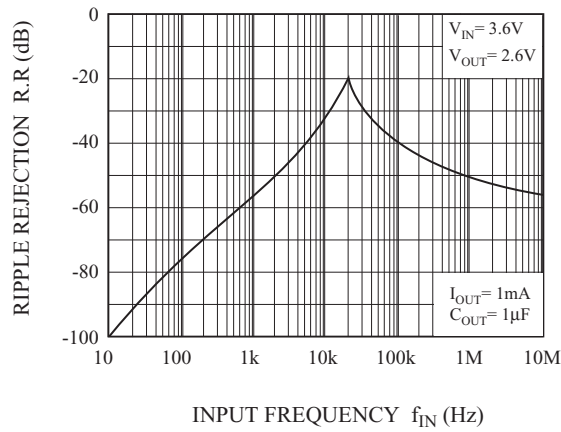

f_{IN} - R.R (4)

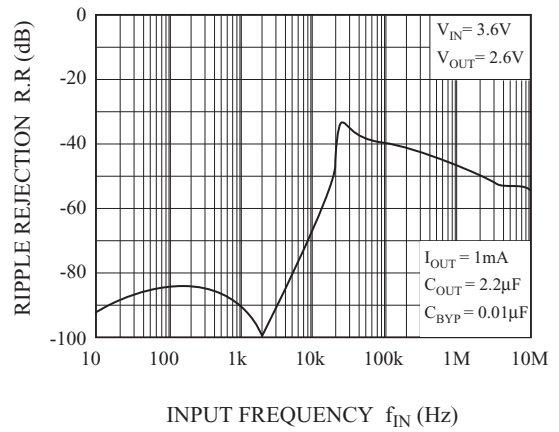

f_{IN} - R.R (5)

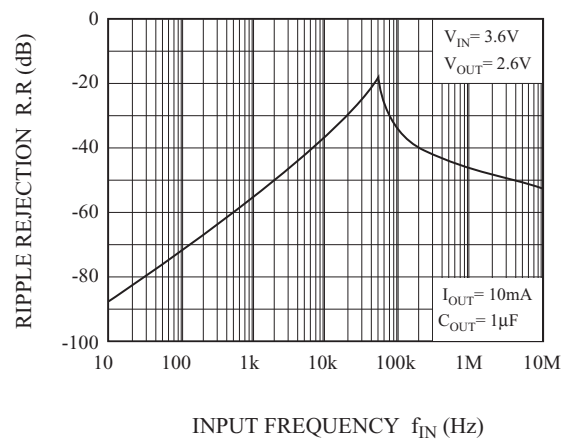

f_{IN} - R.R (6)

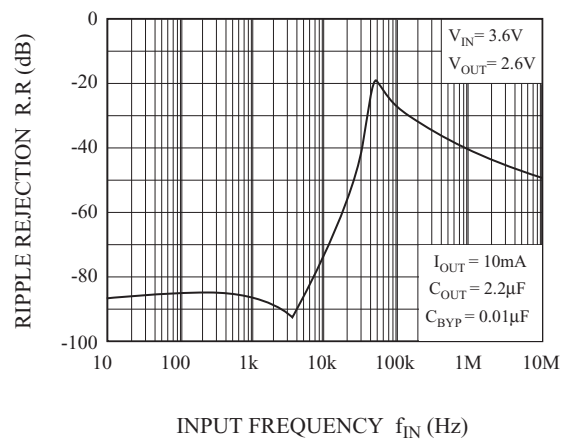

KR32S018M/F~KR32S033M/F

f_{IN} - R.R (7)

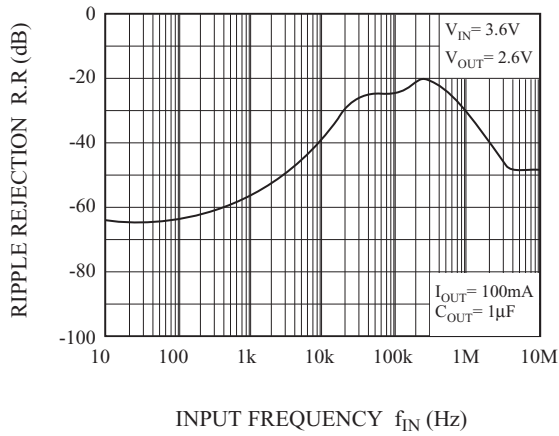

f_{IN} - R.R (8)

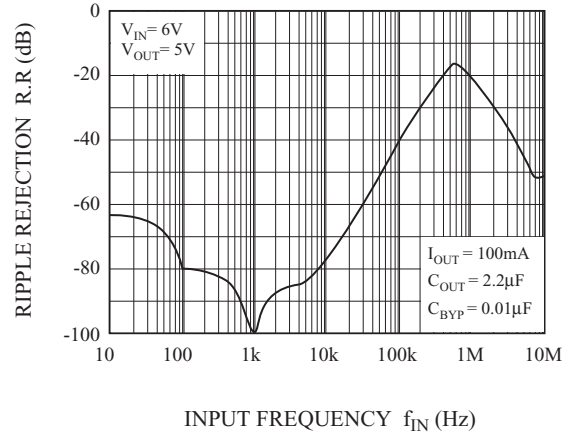

V_D - R.R (1)

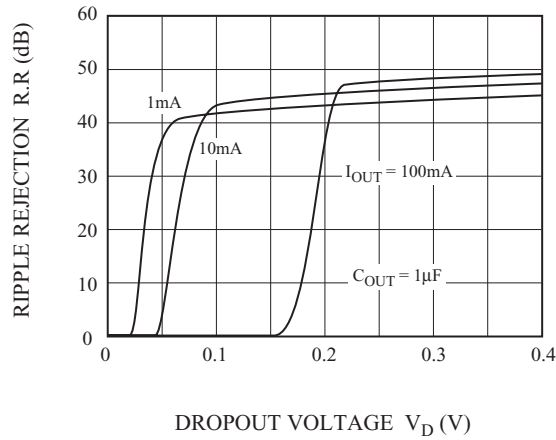

V_D - R.R (2)

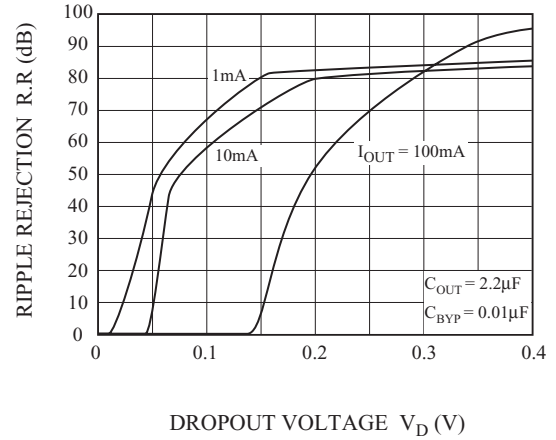

C_{BYPASS} - TIME

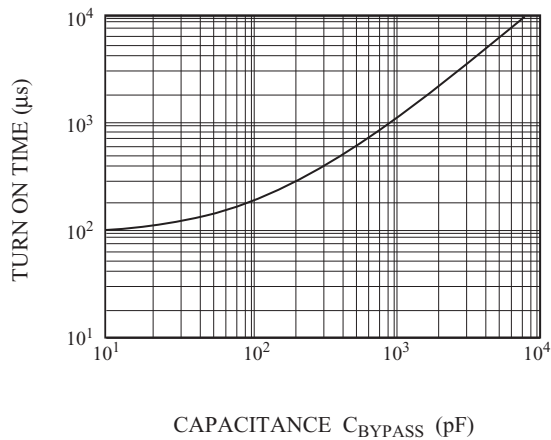

I_{OUT} - V_D

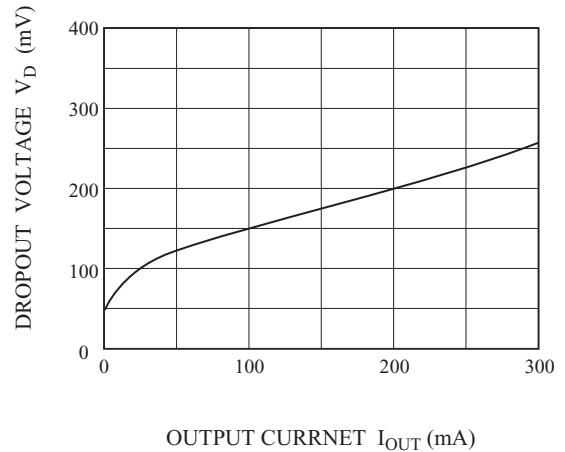

KR32S018M/F~KR32S033M/F

f - NOISE (1)

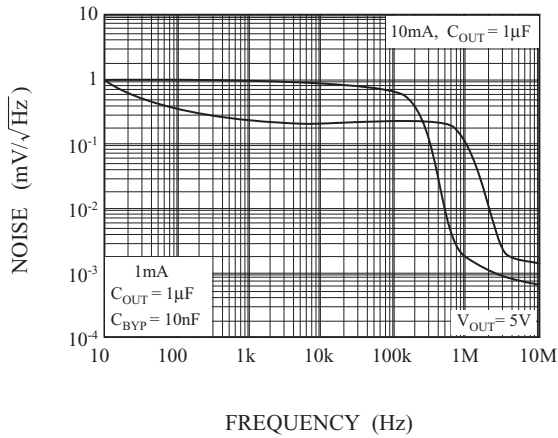

f - NOISE (2)

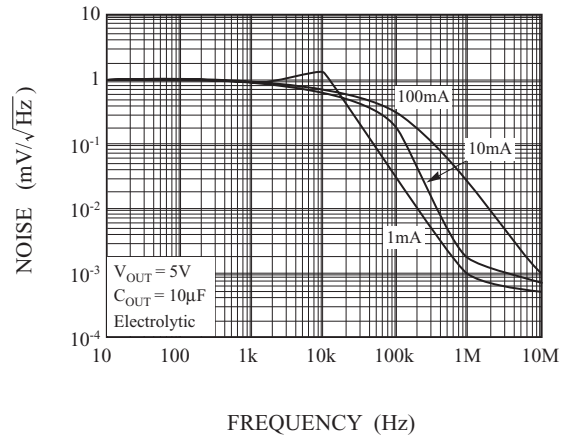

f - NOISE (3)

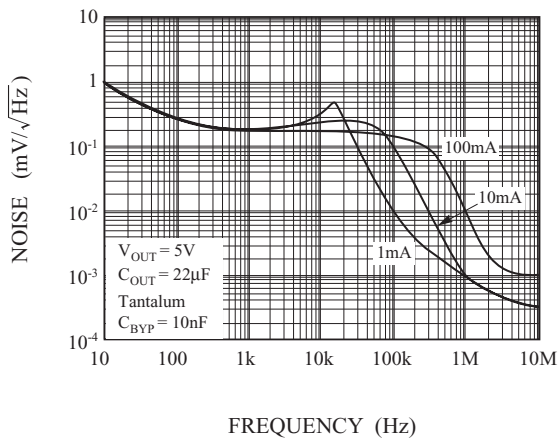

f - NOISE (4)

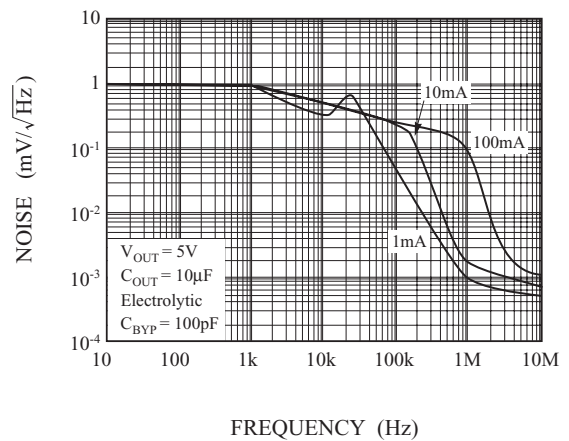

f - NOISE (5)

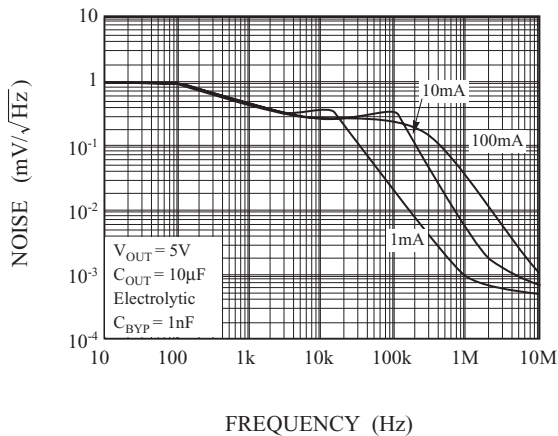

f - NOISE (6)

