

- NOTES:
1. ALL DIMENSION IN MM [INCH]
  2. GENERAL TOLERANCE: X.X=±0.4  
X.XX=±0.25
  3. CONTACT RATING SWITCHING: 150mA, 250V AC/DC  
350mA, 110V AC/DC
  - ▲ 4. CONTACT RATING (NON-SWITCHING) 5A
  5. CONTACT: GOLD FLASH over Silver plated.
  6. OPERATING FORCE: 425±100 CM/STANDARD
  7. OPERATING TEMP: -30° to 85°C
  - ▲ 8. CIRCUIT SP: 3 POSITIONS, 90° INDEX.
  9. DIELECTRIC STRENGTH 1000V RMS min. @ SEA LEVEL
  10. ▲ DENOTES CRITICAL PARAMETER.
  - ▲ 11. HARDWARE SUPPLIED ON SWITCH- SEE BELOW  
STOP RING, LOCKWASHER, & LOCKNUT

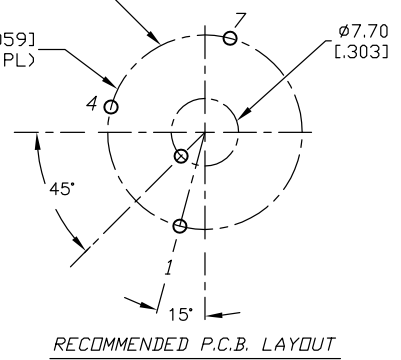
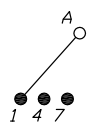

**E-SWITCH®**

TITLE					KC56A13.001NPF				
SCALE	DATE	DR	DWG	REV	SCALE	DATE	DR	DWG	REV
1.5:1	10/1/03	AR	G511001	A					

THE INFORMATION CONTAINED IN THIS DOCUMENT IS PROPRIETARY TO E-SWITCH AND IS NOT TO BE COPIED OR TRANSFERRED