

# DATA SHEET

## **Mono-kap™ series** **Leaded ceramic multilayer capacitors**

Product specification  
Supersedes data of 10th August 1999  
File under BCcomponents, BC06

2000 Aug 24

# Leaded ceramic multilayer capacitors

## Mono-kap™ series

### FEATURES

- Very high capacitance per unit volume
- Low cost.

### APPLICATIONS

These conformally coated radial leaded capacitors are designed for commercial and industrial applications in four dielectrics, NP0 (ultra-stable), X7R (stable) and Z5U, Y5V (general purpose). Applications include timing, coupling/decoupling, signal comparison and biasing. Mono-kap™ capacitors are suitable for automatic insertion equipment.

### DESCRIPTION

The basic capacitor construction consists of ceramic dielectric materials processed into a tape with a typical thickness range from 0.025 to 0.076 mm. Metal electrode patterns are applied using a thick film screening process. Multiple layers are stacked and laminated in such a manner that electrodes are alternately exposed when the pattern is cut into individual chip capacitors. The capacitors are fired through a high temperature profile to mature the ceramic and metal into a homogeneous unit.

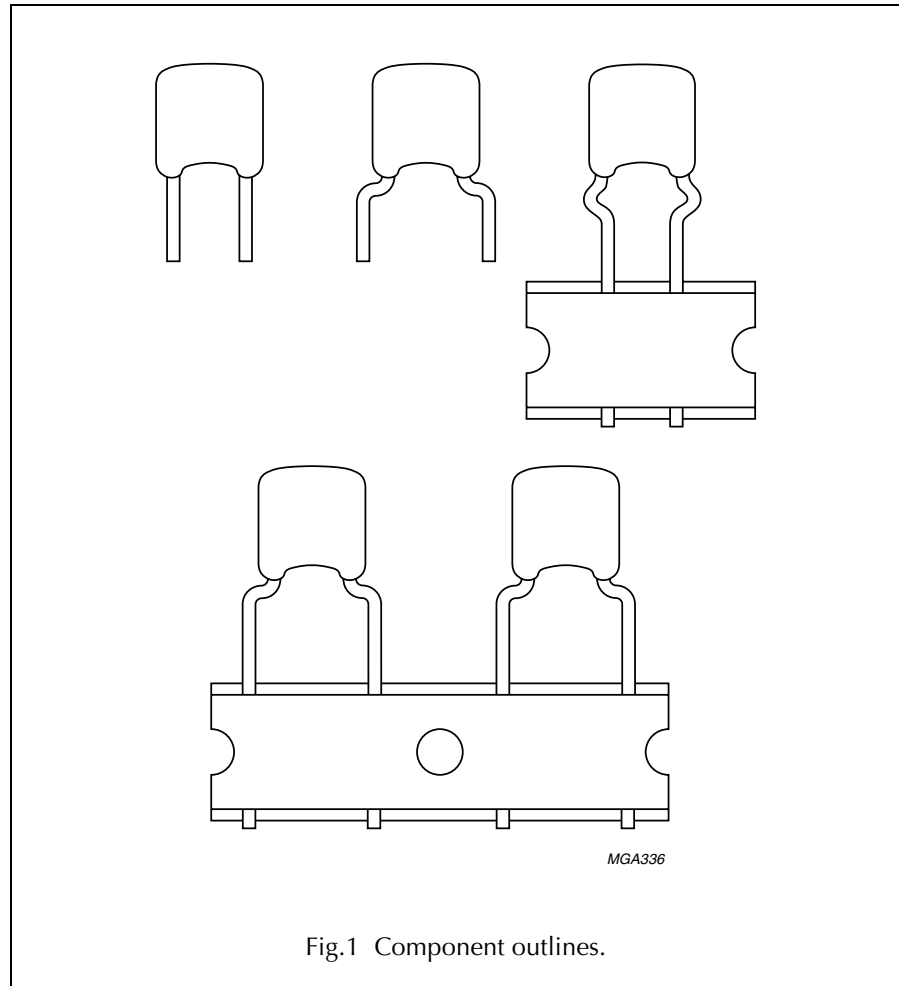

Fig.1 Component outlines.

Metal end terminations are applied and fired to provide electrical connection between the individual layers. Tinned leads are attached using a solder.

Encapsulation consists of a moisture-resistant gold colour conformal epoxy coating that meets the flame requirements of "UL94V-0".

### QUICK REFERENCE DATA

DESCRIPTION	VALUE							
	2252 305 .....	2252 306 .....	2252 325 .....	2252 326 .....	2252 345 .....	2252 346 .....	2252 362 .....	2252 365 .....
Capacitance range	10 pF to 5600 pF		100 pF to 0.22 µF		1000 pF to 1.0 µF		0.01 to 1.0 µF	
Rated DC voltage	50 V	100 V	50 V	100 V	50 V	100 V	25 V	50 V
Tolerance on capacitance	±5%		±10%		±20%		+80%/-20%	
Temperature coefficient	NP0 (COG)		X7R		Z5U		Y5V	

# Leaded ceramic multilayer capacitors

## Mono-kap™ series

### MECHANICAL DATA

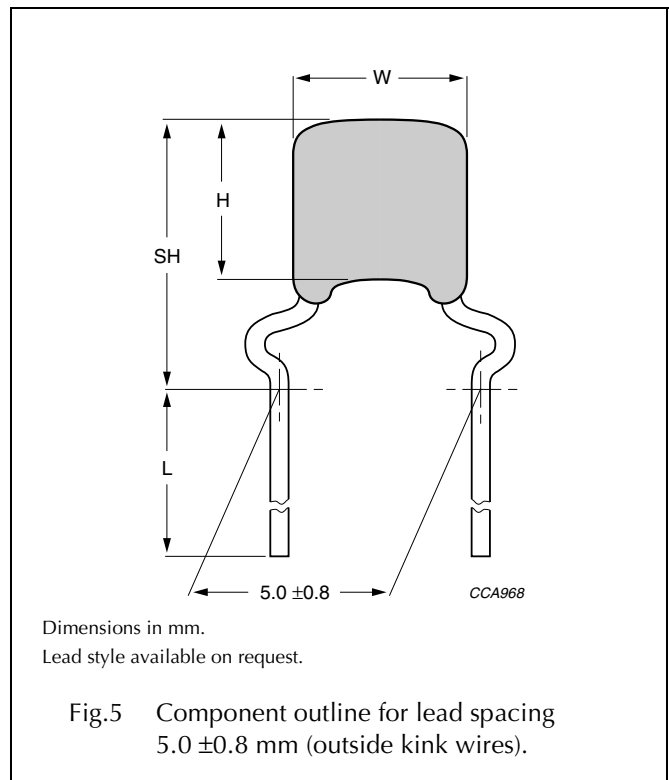
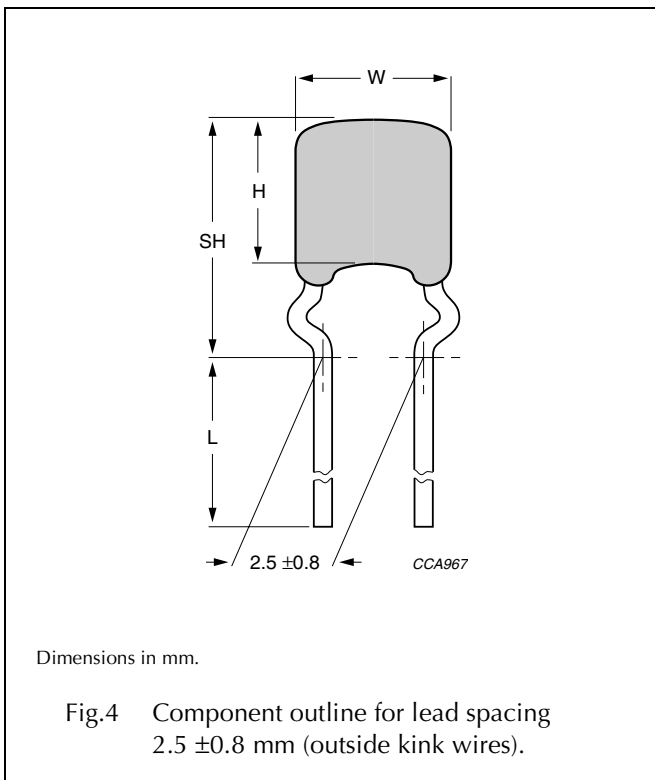
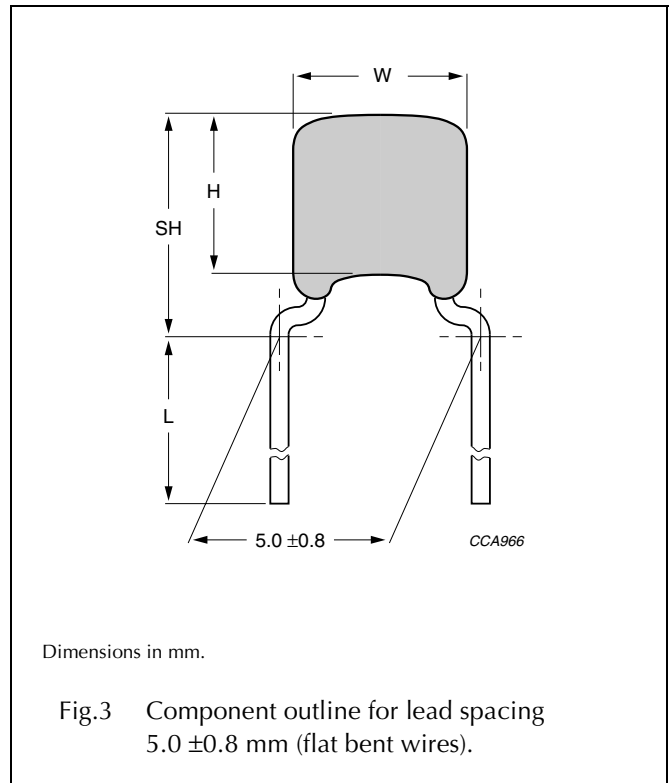
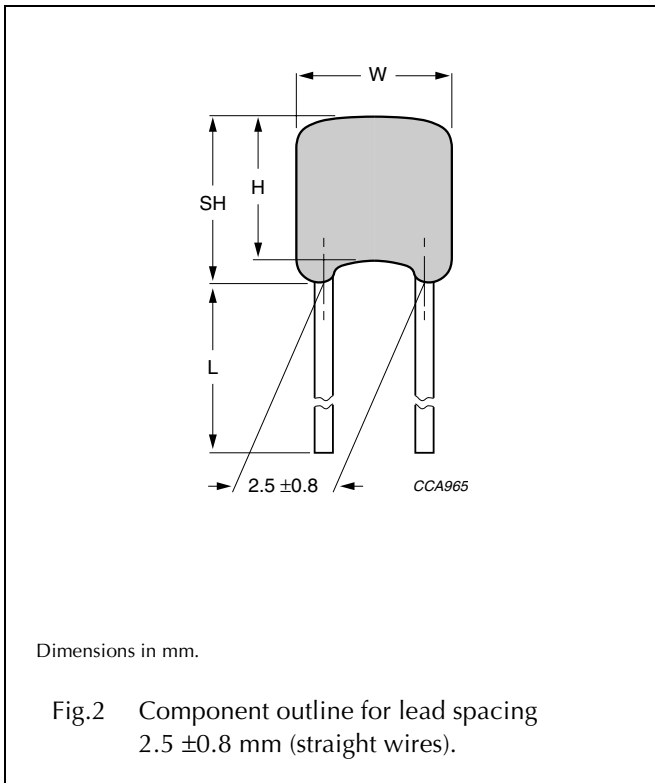

# Leaded ceramic multilayer capacitors

## Mono-kap™ series

### Physical dimensions

**Table 1** Capacitor dimensions and mass; notes 1 and 2

SIZE CODE	W <sub>max</sub> (mm)	H <sub>max</sub> (mm)	T <sub>max</sub> <sup>(3)</sup> (mm)	MAX. SEATING HEIGHT (SH) (mm)				MASS (g)
				Fig.2	Fig.3	Fig.4	Fig.5	
15	4.0 (0.15)	4.0 (0.15)	2.5 (0.100)	5.58 (0.220)	6.50 (0.256)	7.50 (0.295)	7.50 (0.295)	≈0.15
20	5.0 (0.20)	5.0 (0.20)	3.2 (0.13)	6.58 (0.259)	7.50 (0.295)	8.50 (0.335)	8.50 (0.335)	≈0.16

### Notes

1. Bulk packed products have a standard lead length  $L \geq 25.4$  mm.
2. Dimensions between the parentheses are in inches.
3. Thickness defined as T.

### Marking<sup>(1)(2)</sup> (see Fig.6)

#### Capacitance code (CCC):

- 10 pF to 99 pF;  
actual value in pF (2 digits only)
- 100 pF and above;  
coded capacitance value  
(same as used in P/N).

#### Capacitance tolerance (T):

- Standard EIA tolerance.

#### Material code (M):

- A = NP0 (C0G)
- C = X7R
- E = Z5U
- Y = Y5V.

#### Voltage code (V):

- 1 = 100 V
- 3 = 25 V
- 5 = 50 V.

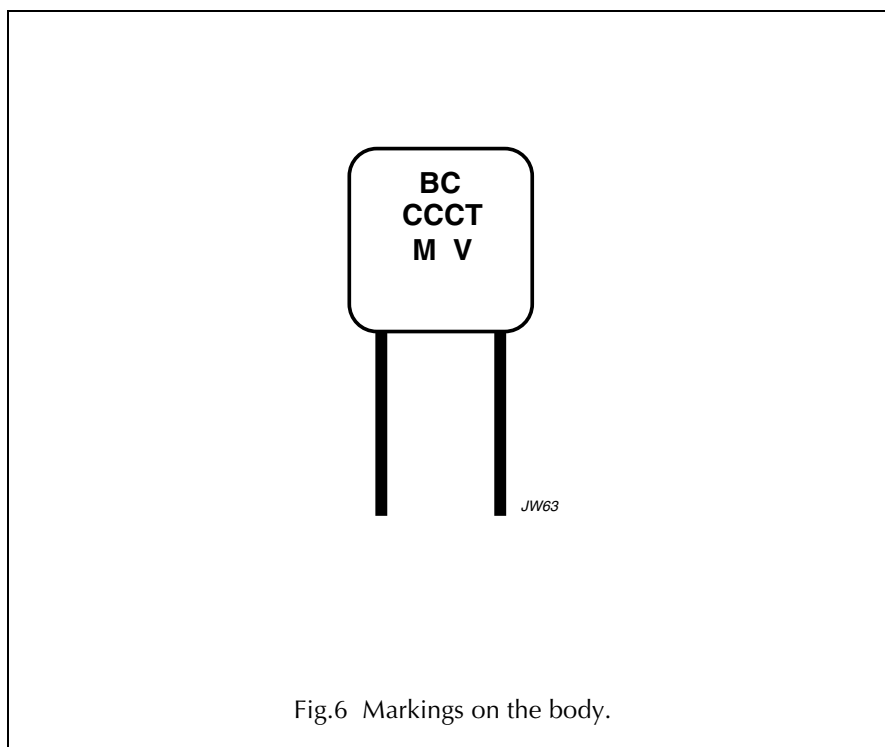

Fig.6 Markings on the body.

### PACKAGING

For details refer to this data handbook, section "Leaded ceramic multilayer capacitors", chapter "Packaging".

- (1) 100 pF and above in size code 15 are marked without capacitance tolerance code (T).
- (2) Only size code 30 and above are marked with the material code (M) and voltage code (V).

# Leaded ceramic multilayer capacitors

## Mono-kap™ series

### ORDERING INFORMATION (preferred types)

**Table 2** Capacitance, rated voltage, mechanical dimensions and ordering information; note 1

C	U <sub>R(DC)</sub> (V)	LEAD SPACING	SIZE CODE	CLEAR TEXT CODE	PACKAGING CODE 8 <sup>th</sup> AND 9 <sup>th</sup> DIGIT			CATALOGUE NUMBER <sup>(2)(3)</sup>
				13 <sup>th</sup> DIGIT: T = REEL; U = AMMO; 3 = BULK	REEL	AMMO	BULK	
<b>NP0 (C0G) ±5% tolerance</b>								
10 pF	50	5.0	15	K100J15C0GF5.H5	10	12	08	2252 305..109
		2.5		K100J15C0GF5.L2	02	03	00	2252 305..109
	100	5.0	15	K100J15C0GH5.H5	10	12	08	2252 306..109
		2.5		K100J15C0GH5.L2	02	03	00	2252 306..109
12 pF	50	5.0	15	K120J15C0GF5.H5	10	12	08	2252 305..129
		2.5		K120J15C0GF5.L2	02	03	00	2252 305..129
15 pF	50	5.0	15	K150J15C0GF5.H5	10	12	08	2252 305..159
		2.5		K150J15C0GF5.L2	02	03	00	2252 305..159
18 pF	50	5.0	15	K180J15C0GF5.H5	10	12	08	2252 305..189
		2.5		K180J15C0GF5.L2	02	03	00	2252 305..189
22 pF	50	5.0	15	K220J15C0GF5.H5	10	12	08	2252 305..229
		2.5		K220J15C0GF5.L2	02	03	00	2252 305..229
	100	5.0	15	K220J15C0GH5.H5	10	12	08	2252 306..229
		2.5		K220J15C0GH5.L2	02	03	00	2252 306..229
27 pF	50	5.0	15	K270J15C0GF5.H5	10	12	08	2252 305..279
		2.5		K270J15C0GF5.L2	02	03	00	2252 305..279
33 pF	50	5.0	15	K330J15C0GF5.H5	10	12	08	2252 305..339
		2.5		K330J15C0GF5.L2	02	03	00	2252 305..339
39 pF	50	5.0	15	K390J15C0GF5.H5	10	12	08	2252 305..399
		2.5		K390J15C0GF5.L2	02	03	00	2252 305..399
47 pF	50	5.0	15	K470J15C0GF5.H5	10	12	08	2252 305..479
		2.5		K470J15C0GF5.L2	02	03	00	2252 305..479
	100	5.0	15	K470J15C0GH5.H5	10	12	08	2252 306..479
		2.5		K470J15C0GH5.L2	02	03	00	2252 306..479
56 pF	50	5.0	15	K560J15C0GF5.H5	10	12	08	2252 305..569
		2.5		K560J15C0GF5.L2	02	03	00	2252 305..569
68 pF	50	5.0	15	K680J15C0GF5.H5	10	12	08	2252 305..689
		2.5		K680J15C0GF5.L2	02	03	00	2252 305..689
82 pF	50	5.0	15	K820J15C0GF5.H5	10	12	08	2252 305..829
		2.5		K820J15C0GF5.L2	02	03	00	2252 305..829
100 pF	50	5.0	15	K101J15C0GF5.H5	10	12	08	2252 305..101
		2.5		K101J15C0GF5.L2	02	03	00	2252 305..101
	100	5.0	15	K101J15C0GH5.H5	10	12	08	2252 306..101
		2.5		K101J15C0GH5.L2	02	03	00	2252 306..101

# Leaded ceramic multilayer capacitors

## Mono-kap™ series

C	U <sub>R(DC)</sub> (V)	LEAD SPACING	SIZE CODE	CLEAR TEXT CODE	PACKAGING CODE 8 <sup>th</sup> AND 9 <sup>th</sup> DIGIT			CATALOGUE NUMBER <sup>(2)</sup> / <sub>(3)</sub>
				13 <sup>th</sup> DIGIT: T = REEL; U = AMMO; 3 = BULK	REEL	AMMO	BULK	
150 pF	50	5.0	15	K151J15C0GF5.H5	10	12	08	2252 305..151
		2.5		K151J15C0GF5.L2	02	03	00	2252 305..151
220 pF	50	5.0	15	K221J15C0GF5.H5	10	12	08	2252 305..221
		2.5		K221J15C0GF5.L2	02	03	00	2252 305..221
	100	5.0	15	K221J15C0GH5.H5	10	12	08	2252 306..221
		2.5		K221J15C0GH5.L2	02	03	00	2252 306..221
330 pF	50	5.0	15	K331J15C0GF5.H5	10	12	08	2252 305..331
		2.5		K331J15C0GF5.L2	02	03	00	2252 305..331
470 pF	50	5.0	15	K471J15C0GF5.H5	10	12	08	2252 305..471
		2.5		K471J15C0GF5.L2	02	03	00	2252 305..471
	100	5.0	15	K471J15C0GH5.H5	10	12	08	2252 306..471
		2.5		K471J15C0GH5.L2	02	03	00	2252 306..471
680 pF	50	5.0	15	K681J15C0GF5.H5	10	12	08	2252 305..681
		2.5		K681J15C0GF5.L2	02	03	00	2252 305..681
1 000 pF	50	5.0	15	K102J15C0GF5.H5	10	12	08	2252 305..102
		2.5		K102J15C0GF5.L2	02	03	00	2252 305..102
	100	5.0	20	K102J20C0GH5.H5	24	26	22	2252 306..102
		2.5		K102J20C0GH5.L2	16	17	14	2252 306..102
1500 pF	50	5.0	15	K152J15C0GF5.H5	10	12	08	2252 305..152
2200 pF	50	5.0	15	K222J15C0GF5.H5	10	12	08	2252 305..222
3300 pF	50	5.0	20	K332J20C0GF5.H5	24	26	22	2252 305..332
4700 pF	50	5.0	20	K472J20C0GF5.H5	24	26	22	2252 305..472

# Leaded ceramic multilayer capacitors

## Mono-kap™ series

C	U <sub>R(DC)</sub> (V)	LEAD SPACING	SIZE CODE	CLEAR TEXT CODE	PACKAGING CODE 8 <sup>th</sup> AND 9 <sup>th</sup> DIGIT			CATALOGUE NUMBER <sup>(2)</sup> / <sub>(3)</sub>
				13 <sup>th</sup> DIGIT: T = REEL; U = AMMO; 3 = BULK	REEL	AMMO	BULK	
<b>X7R ±10% tolerance</b>								
220 pF	50	5.0	15	K221K15X7RF5.H5	10	12	08	2252 325..221
		2.5		K221K15X7RF5.L2	02	03	00	2252 325..221
	100	5.0	15	K221K15X7RH5.H5	10	12	08	2252 326..221
		2.5		K221K15X7RH5.L2	02	03	00	2252 326..221
330 pF	50	5.0	15	K331K15X7RF5.H5	10	12	08	2252 325..331
		2.5		K331K15X7RF5.L2	02	03	00	2252 325..331
470 pF	50	5.0	15	K471K15X7RF5.H5	10	12	08	2252 325..471
		2.5		K471K15X7RF5.L2	02	03	00	2252 325..471
	100	5.0	15	K471K15X7RH5.H5	10	12	08	2252 326..471
		2.5		K471K15X7RH5.L2	02	03	00	2252 326..471
680 pF	50	5.0	15	K681K15X7RF5.H5	10	12	08	2252 325..681
		2.5		K681K15X7RF5.L2	02	03	00	2252 325..681
1 000 pF	50	5.0	15	K102K15X7RF5.H5	10	12	08	2252 325..102
		2.5		K102K15X7RF5.L2	02	03	00	2252 325..102
	100	5.0	15	K102K15X7RH5.H5	10	12	08	2252 326..102
		2.5		K102K15X7RH5.L2	02	03	00	2252 326..102
1 500 pF	50	5.0	15	K152K15X7RF5.H5	10	12	08	2252 325..152
		2.5		K152K15X7RF5.L2	02	03	00	2252 325..152
2 200 pF	50	5.0	15	K222K15X7RF5.H5	10	12	08	2252 325..222
		2.5		K222K15X7RF5.L2	02	03	00	2252 325..222
	100	5.0	15	K222K15X7RH5.H5	10	12	08	2252 326..222
		2.5		K222K15X7RH5.L2	02	03	00	2252 326..222
3 300 pF	50	5.0	15	K332K15X7RF5.H5	10	12	08	2252 325..332
		2.5		K332K15X7RF5.L2	02	03	00	2252 325..332
4 700 pF	50	5.0	15	K472K15X7RF5.H5	10	12	08	2252 325..472
		2.5		K472K15X7RF5.L2	02	03	00	2252 325..472
	100	5.0	15	K472K15X7RH5.H5	10	12	08	2252 326..472
		2.5		K472K15X7RH5.L2	02	03	00	2252 326..472
6 800 pF	50	5.0	15	K682K15X7RF5.H5	10	12	08	2252 325..682
		2.5		K682K15X7RF5.L2	02	03	00	2252 325..682
0.01 µF	50	5.0	15	K103K15X7RF5.H5	10	12	08	2252 325..103
		2.5		K103K15X7RF5.L2	02	03	00	2252 325..103
	100	5.0	15	K103K15X7RH5.H5	10	12	08	2252 326..103
		2.5		K103K15X7RH5.L2	02	03	00	2252 326..103
0.015 µF	50	5.0	15	K153K15X7RF5.H5	10	12	08	2252 325..153
		2.5		K153K15X7RF5.L2	02	03	00	2252 325..153

# Leaded ceramic multilayer capacitors

## Mono-kap™ series

C	U <sub>R(DC)</sub> (V)	LEAD SPACING	SIZE CODE	CLEAR TEXT CODE	PACKAGING CODE 8 <sup>th</sup> AND 9 <sup>th</sup> DIGIT			CATALOGUE NUMBER <sup>(2)</sup> / <sub>(3)</sub>
				13 <sup>th</sup> DIGIT: T = REEL; U = AMMO; 3 = BULK	REEL	AMMO	BULK	
0.022 µF	50	5.0	15	K223K15X7RF5.H5	10	12	08	2252 325..223
		2.5		K223K15X7RF5.L2	02	03	00	2252 325..223
	100	5.0	20	K223K20X7RH5.H5	24	26	22	2252 326..223
		2.5		K223K20X7RH5.L2	16	17	14	2252 326..223
0.033 µF	50	5.0	15	K333K15X7RF5.H5	10	12	08	2252 325..333
		2.5		K333K15X7RF5.L2	02	03	00	2252 325..333
0.047 µF	50	5.0	15	K473K15X7RF5.H5	10	12	08	2252 325..473
		2.5		K473K15X7RF5.L2	02	03	00	2252 325..473
	100	5.0	20	K473K20X7RH5.H5	24	26	22	2252 326..473
		2.5		K473K20X7RH5.L2	16	17	14	2252 326..473
0.068 µF	50	5.0	15	K683K15X7RF5.H5	10	12	08	2252 325..683
		2.5		K683K15X7RF5.L2	02	03	00	2252 325..683
0.1 µF	50	5.0	15	K104K15X7RF5.H5	10	12	08	2252 325..104
		2.5		K104K15X7RF5.L2	02	03	00	2252 325..104
	100	5.0	20	K104K20X7RH5.H5	24	26	22	2252 326..104
		2.5		K104K20X7RH5.L2	16	17	14	2252 326..104
0.15 µF	50	5.0	20	K154K20X7RF5.H5	24	26	22	2252 325..154
0.22 µF	50	5.0	20	K224K20X7RF5.H5	24	26	22	2252 325..224
<b>Z5U ±20% tolerance</b>								
0.01 µF	50	5.0	15	K103M15Z5UF5.H5	10	12	08	2252 345..103
		2.5		K103M15Z5UF5.L2	02	03	00	2252 345..103
	100	5.0	15	K103M15Z5UH5.H5	10	12	08	2252 346..103
		2.5		K103M15Z5UH5.L2	02	03	00	2252 346..103
0.022 µF	50	5.0	15	K223M15Z5UF5.H5	10	12	08	2252 345..223
		2.5		K223M15Z5UF5.L2	02	03	00	2252 345..223
0.047 µF	50	5.0	15	K473M15Z5UF5.H5	10	12	08	2252 345..473
		2.5		K473M15Z5UF5.L2	02	03	00	2252 345..473
0.1 µF	50	5.0	15	K104M15Z5UF5.H5	10	12	08	2252 345..104
		2.5		K104M15Z5UF5.L2	02	03	00	2252 345..104
	100	5.0	20	K104M20Z5UH5.H5	24	26	22	2252 346..104
		2.5		K104M20Z5UH5.L2	16	17	14	2252 346..104



# Leaded ceramic multilayer capacitors

## Mono-kap™ series

C	U <sub>R(DC)</sub> (V)	LEAD SPACING	SIZE CODE	CLEAR TEXT CODE	PACKAGING CODE 8 <sup>th</sup> AND 9 <sup>th</sup> DIGIT			CATALOGUE NUMBER <sup>(2)</sup> / <sub>(3)</sub>
				13 <sup>th</sup> DIGIT: T = REEL; U = AMMO; 3 = BULK	REEL	AMMO	BULK	
0.15 µF	50	5.0	15	K154M15Z5UF5.H5	10	12	08	2252 345..154
		2.5		K154M15Z5UF5.L2	02	03	00	2252 345..154
0.22 µF	50	5.0	15	K224M15Z5UF5.H5	10	12	08	2252 345..224
		2.5		K224M15Z5UF5.L2	02	03	00	2252 345..224
0.33 µF	50	5.0	20	K334M20Z5UF5.H5	24	26	22	2252 345..334
0.47 µF	50	5.0	20	K474M20Z5UF5.H5	24	26	22	2252 345..474
0.68 µF	50	5.0	20	K684M20Z5UF5.H5	24	26	22	2252 345..684
1.0 µF	50	5.0	20	K105M20Z5UF5.H5	24	26	22	2252 345..105
<b>Y5V +80/-20% tolerance</b>								
0.1 µF	25	5.0	15	K104Z15Y5VE5.H5	10	12	08	2252 362..104
		2.5		K104Z15Y5VE5.L2	02	03	00	2252 362..104
	50	5.0	15	K104Z15Y5VF5.H5	10	12	08	2252 365..104
		2.5		K104Z15Y5VF5.L2	02	03	00	2252 365..104
0.22 µF	25	5.0	15	K224Z15Y5VE5.H5	10	12	08	2252 362..224
		2.5		K224Z15Y5VE5.L2	02	03	00	2252 362..224
	50	5.0	15	K224Z15Y5VF5.H5	10	12	08	2252 365..224
		2.5		K224Z15Y5VF5.L2	02	03	00	2252 365..224
0.47 µF	25	5.0	20	K474Z20Y5VE5.H5	24	26	22	2252 362..474
		2.5		K474Z20Y5VE5.L2	16	17	14	2252 362..474
	50	5.0	20	K474Z20Y5VF5.H5	24	26	22	2252 365..474
		2.5		K474Z20Y5VF5.L2	16	17	14	2252 365..474
1.0 µF	25	5.0	20	K105Z20Y5VE5.H5	24	26	22	2252 362..105
		2.5		K105Z20Y5VE5.L2	16	17	14	2252 362..105
	50	5.0	20	K105Z20Y5VF5.H5	24	26	22	2252 365..105
		2.5		K105Z20Y5VF5.L2	16	17	14	2252 365..105

### Notes

1. For maximum thickness refer to Table 1.
2. 8<sup>th</sup> and 9<sup>th</sup> digit of the catalogue number to be completed with the packaging code.
3. Packaging codes refer to straight leads for F = 2.5 mm and flat bent leads for F = 5.0 mm.  
Other styles available on request.

## Leaded ceramic multilayer capacitors

## Mono-kap™ series

### ELECTRICAL CHARACTERISTICS

**Table 3** Electrical data for NP0, X7R, Z5U and Y5V

The capacitors meet the essential requirements of "IEC 60384-8", "IEC 60384-9" and "EIA 198".

Unless stated otherwise all electrical values apply at an ambient temperature of  $25 \pm 3$  °C, at barometric pressures of 650 to 800 mm of mercury, and relative humidity not to exceed 75%.

DESCRIPTION	VALUE
<b>Capacitors with temperature coefficient NP0</b>	
Capacitance range: at 1 MHz, 1 V; where $C \leq 1000$ pF at 1 kHz, 1 V; where $C > 1000$ pF	10 to 1000 pF 1200 pF to 5 600 pF
Tolerance on the capacitance	$\pm 5\%$ ; $\pm 10\%$
Rated DC voltage	50 and 100 V
Dielectric strength	250% of rated voltage
Insulation resistance at rated voltage	100000 M $\Omega$ or 1000 M $\Omega \times \mu\text{F}$ , whichever is less at rated voltage within 2 minutes of charging
Temperature coefficient of the capacitance	$0 \times 10^{-6}/\text{K}$
Tolerance on the temperature coefficient	$\pm 30 \times 10^{-6}/\text{K}$
Dissipation factor: at 1 MHz, 1 V; where $C \leq 30$ pF at 1 kHz, 1 V; where $C > 30$ pF	$< \frac{1}{(400 + 20 \times C)}$ $< 15 \times 10^{-4}$
Operating temperature range	$-55$ to $+125$ °C
Storage temperature range	$25 \pm 15$ °C
<b>Capacitors with temperature coefficient X7R</b>	
Capacitance range at 1 kHz, 1 V	100 pF to 0.22 $\mu\text{F}$
Tolerance on the capacitance	$\pm 10\%$ ; $\pm 20\%$
Maximum capacitance variation with respect to capacitance value at 25 °C	$\pm 15\%$
Rated DC voltage	50 and 100 V
Dielectric strength	250% of rated voltage
Insulation resistance at rated voltage	100000 M $\Omega$ or 1000 M $\Omega \times \mu\text{F}$ , whichever is less at rated voltage within 2 minutes of charging
Dissipation factor at 1 kHz, 1 V	$\leq 2.5\%$
Operating temperature range	$-55$ to $+125$ °C
Storage temperature range	$25 \pm 15$ °C

## Leaded ceramic multilayer capacitors

## Mono-kap™ series

DESCRIPTION	VALUE
Ageing	typical 1% per time decade
<b>Capacitors with temperature coefficient Z5U</b>	
Capacitance range at 1 kHz, 0.5 V	1 000 pF to 1.0 μF
Tolerance on the capacitance	±20%; +80%/-20%
Maximum capacitance variation with respect to capacitance value at 25 °C	-56%/+22%
Rated DC voltage	50 and 100 V
Dielectric strength	250% of rated voltage
Insulation resistance at rated voltage	10 000 MΩ or 1 000 MΩ × μF, whichever is less at rated voltage within 2 minutes of charging
Dissipation factor at 1 kHz, 0.5 V	≤4%
Operating temperature range	10 to 85 °C
Storage temperature range	25 ±15 °C
Ageing	typical 6% per time decade
<b>Capacitors with temperature coefficient Y5V</b>	
Capacitance range at 1 kHz, 1 V	0.01 to 1.0 μF
Tolerance on the capacitance	+80%/-20%
Maximum capacitance variation with respect to capacitance value at 25 °C	-82%/+22%
Rated DC voltage	25 and 50 V
Dielectric strength	250% of rated voltage
Insulation resistance at rated voltage	10 000 MΩ or 1 000 MΩ × μF, whichever is less at rated voltage within 2 minutes of charging
Dissipation factor at 1 kHz, 1 V	≤5%
Operating temperature range	10 to 85 °C
Storage temperature range	25 ±15 °C
Ageing	typical 6% per time decade