

## Wide variation 1a 15A, 2a 10A power relays

# JC RELAYS



PC board type

Plug-in type

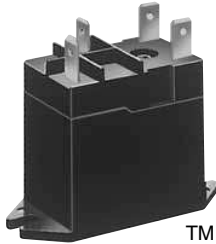

TM type

### FEATURES

- **High inrush current capability**  
1 Form A: 163 A inrush (TV-8)  
2 Form A: 111 A inrush (TV-5)
- **High dielectric withstanding for transient protection:**  
JC can withstand 10,000 V surge in  $\mu$ s between coil and contact.
- **Electrical life:**  
1 Form A:  $10^5$  ope. at 15 A 250 V AC resistive load  
2 Form A:  $10^5$  ope. at 10 A 250 V AC resistive load
- **UL, CSA, VDE, TÜV, SEMKO also approved.**

### TYPICAL APPLICATIONS

- Automatic garage door openers
- Microwave ovens
- Dryers
- Vending machines
- Copiers
- Air conditioners
- Stereo equipment
- TV sets

Compliance with RoHS Directive

### ORDERING INFORMATION

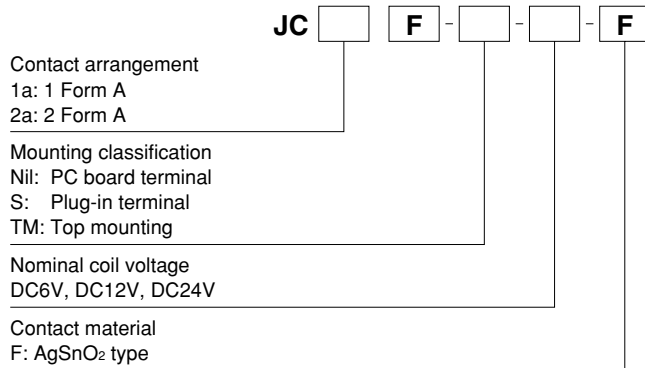

Note: Certified by UL, CSA, VDE, TÜV and SEMKO

### TYPES

Contact arrangement	Nominal coil voltage	PC board type	Plug-in type	Top mounting type
		Part No.	Part No.	Part No.
1 Form A	6V DC	JC1aF-DC6V-F	JC1aF-S-DC6V-F	JC1aF-TM-DC6V-F
	12V DC	JC1aF-DC12V-F	JC1aF-S-DC12V-F	JC1aF-TM-DC12V-F
	24V DC	JC1aF-DC24V-F	JC1aF-S-DC24V-F	JC1aF-TM-DC24V-F
2 Form A	6V DC	JC2aF-DC6V-F	JC2aF-S-DC6V-F	JC2aF-TM-DC6V-F
	12V DC	JC2aF-DC12V-F	JC2aF-S-DC12V-F	JC2aF-TM-DC12V-F
	24V DC	JC2aF-DC24V-F	JC2aF-S-DC24V-F	JC2aF-TM-DC24V-F

Standard packing; PC board type: Carton 50 pcs. Case 200 pcs.  
Plug-in and Top mounting type: Carton 20 pcs. Case 200 pcs.  
Notes: 1. Please refer to the "Standards Chart" for product certification.  
2. 5 V DC type is also available.

# RATING

## 1. Coil data

Contact arrangement	Nominal coil voltage	Pick-up voltage (at 20°C 68°F)	Drop-out voltage (at 20°C 68°F)	Nominal operating current [ $\pm 10\%$ ] (at 20°C 68°F)	Coil resistance [ $\pm 10\%$ ] (at 20°C 68°F)	Nominal operating power	Max. applied voltage (at 60°C 140°F)
1 Form A	6V DC	80%V or less of nominal voltage (Initial)	10%V or more of nominal voltage (Initial)	150 mA	40 $\Omega$	0.9W	110%V of nominal voltage
	12V DC			75 mA	160 $\Omega$	0.9W	
	24V DC			37.5mA	640 $\Omega$	0.9W	
2 Form A	6V DC			166.6mA	36 $\Omega$	1.0W	
	12V DC			83.3mA	144 $\Omega$	1.0W	
	24V DC			41.6mA	576 $\Omega$	1.0W	

## 2. Specifications

Characteristics	Item	Specifications	
Contact	Contact material	AgSnO <sub>2</sub> type	
	Arrangement	1 Form A / 2 Form A	
	Contact resistance (Initial)	Max. 100 m $\Omega$ (By voltage drop 6 V DC 1A)	
	Contact force	Min. 30 g	
Rating	Nominal switching capacity (resistive load)	15A 250V AC / 10A 250V AC	
	Max. switching power (resistive load)	3,750VA / 2,500VA	
	Max. switching voltage	250V AC	
	Max. switching current	15A / 10A	
	Nominal operating power	900mW / 1,000mW	
	Min. switching capacity (reference value)*1	100mA, 5V DC	
Electrical characteristics	Insulation resistance (Initial)	Min. 100M $\Omega$ (at 500V DC) Measurement at same location as "Breakdown voltage" section.	
	Breakdown voltage (Initial)	Between open contacts	2,000 Vrms for 1 min. (Detection current: 10 mA)
		Between contacts sets	— / 2,000 Vrms for 1 min. (Detection current: 10 mA)
		Between contact and coil	4,000 Vrms for 1 min. (Detection current: 10 mA)
	Temperature rise (coil)	Max. 55°C 131°F (By resistive method, nominal coil voltage applied to the coil, at 60°C 140°F)	
	Surge breakdown voltage*2 (Between contact and coil) (Initial)	10,000 V	
	Operate time (at nominal voltage) (at 20°C 68°F)	Max. 30 ms (excluding contact bounce time.)	
	Release time (at nominal voltage) (at 20°C 68°F)	Max. 10 ms (excluding contact bounce time) (Without diode)	
Mechanical characteristics	Shock resistance	Functional	196 m/s <sup>2</sup> (Half-wave pulse of sine wave: 11 ms; detection time: 10 $\mu$ s.)
		Destructive	980 m/s <sup>2</sup> (Half-wave pulse of sine wave: 6 ms.)
	Vibration resistance	Functional	10 to 55 Hz at double amplitude of 1.6 mm (Detection time: 10 $\mu$ s.)
		Destructive	10 to 55 Hz at double amplitude of 2.0 mm
Expected life	Mechanical (at 180 times/min.)	Min. 5 $\times 10^6$	
	Electrical (at 20 times/min.)	Min. 10 <sup>5</sup> (10A 250V AC at rated load), Min. 10 <sup>5</sup> (5A 250V AC at rated load)	
Conditions	Conditions for operation, transport and storage*3	Ambient temperature: -50°C to +60°C -58°F to +140°F, Humidity: 5 to 85% R.H. (Not freezing and condensing at low temperature)	
	Max. operating speed	20 times/min. (at nominal switching capacity)	
Unit weight		Approx. 31 g 1.09 oz	

\* Specifications will vary with foreign standards certification ratings.

Notes: \*1. This value can change due to the switching frequency, environmental conditions, and desired reliability level, therefore it is recommended to check this with the actual load.

\*2. Wave is standard shock voltage of  $\pm 1.2 \times 50\mu$ s according to JEC-212-1981

\*3. The upper limit of the ambient temperature is the maximum temperature that can satisfy the coil temperature rise value. Refer to Usage, transport and storage conditions in NOTES.

# REFERENCE DATA

## JC1a type

### 1. Maximum value for switching capacity

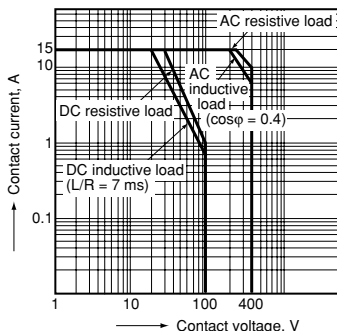

### 2. Operate / release time

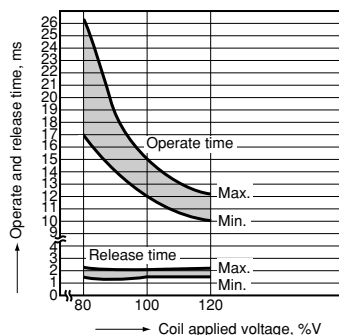

JC2a type

1. Maximum value for switching capacity

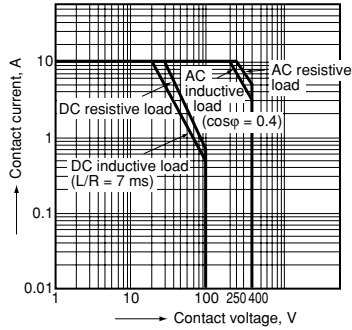

2. Operate / release time

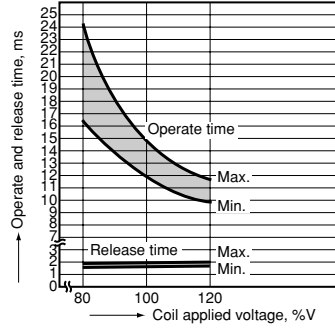

**DIMENSIONS** (mm inch)

The CAD data of the products with a **CAD Data** mark can be downloaded from: <http://panasonic-electric-works.net/ac>

PC board type

1) JC 1 Form A

**CAD Data**



External dimensions

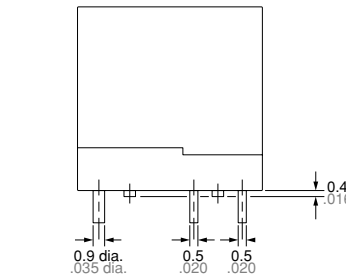
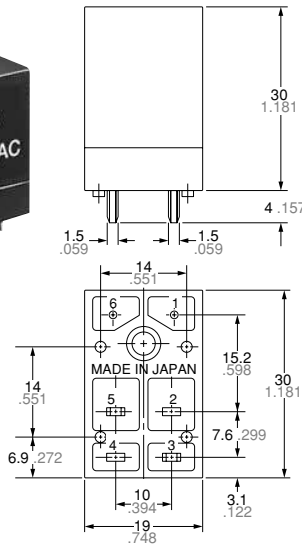

**Dimension:**  
 Less than 1mm .039inch:  $\pm 0.2 \pm 0.08$   
 Min. 1mm .039inch  
 less than 3mm .118 inch:  $\pm 0.3 \pm 0.12$   
 Min. 3mm .118 inch:  $\pm 0.5 \pm 0.20$

Schematic (Bottom view)

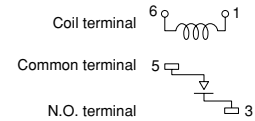

PC board pattern (Bottom view)

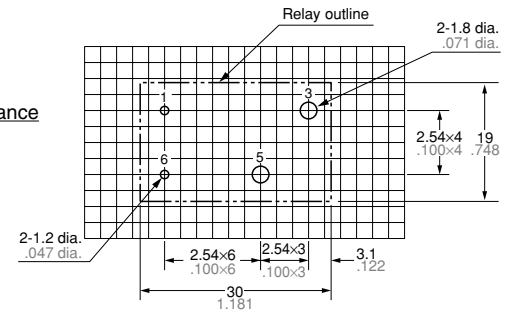

Tolerance:  $\pm 0.1 \pm 0.04$

2) JC 2 Form A

**CAD Data**



External dimensions

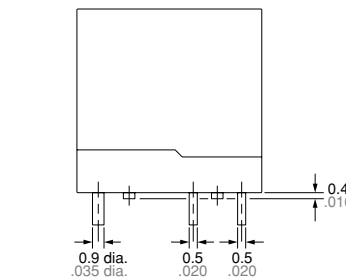
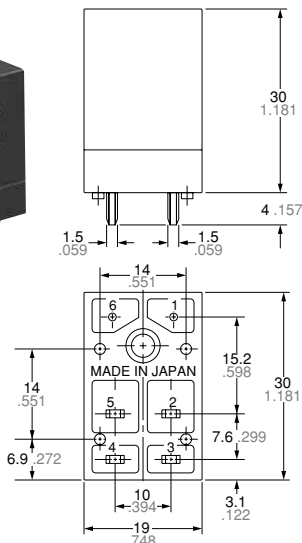

**Dimension:**  
 Less than 1mm .039inch:  $\pm 0.2 \pm 0.08$   
 Min. 1mm .039inch  
 less than 3mm .118 inch:  $\pm 0.3 \pm 0.12$   
 Min. 3mm .118 inch:  $\pm 0.5 \pm 0.20$

Schematic (Bottom view)

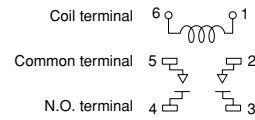

PC board pattern (Bottom view)

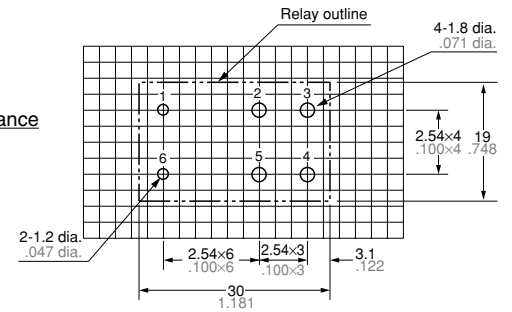

Tolerance:  $\pm 0.1 \pm 0.04$

# JC

## Plug-in type

### 1) JC 1 Form A

#### CAD Data



#### External dimensions

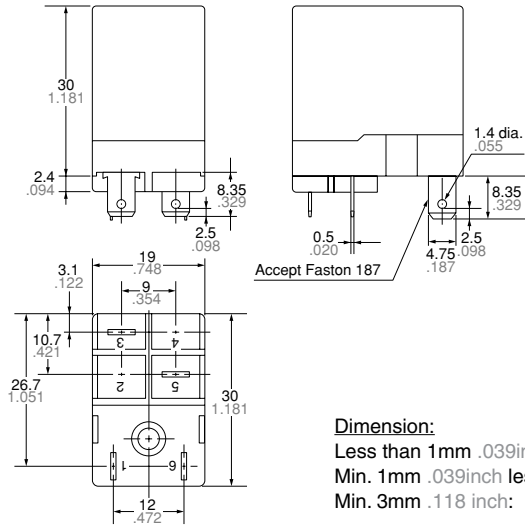

#### Dimension:

Less than 1mm .039inch:

Min. 1mm .039inch less than 3mm .118 inch:

Min. 3mm .118 inch:

#### Schematic (Bottom view)

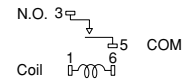

#### General tolerance

$\pm 0.2 \pm 0.08$

$\pm 0.3 \pm 0.12$

$\pm 0.5 \pm 0.20$

### 2) JC 2 Form A

#### CAD Data



#### External dimensions

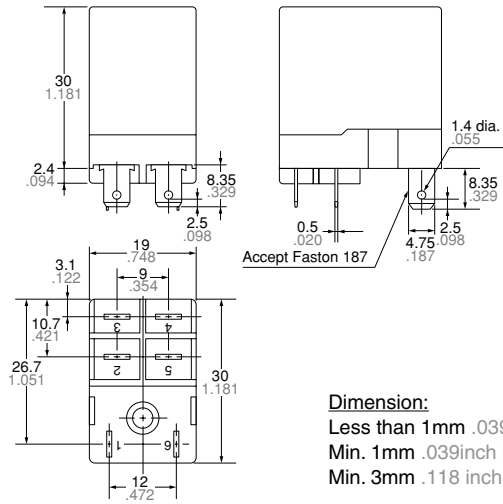

#### Dimension:

Less than 1mm .039inch:

Min. 1mm .039inch less than 3mm .118 inch:

Min. 3mm .118 inch:

#### Schematic (Bottom view)

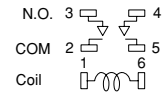

#### General tolerance

$\pm 0.2 \pm 0.08$

$\pm 0.3 \pm 0.12$

$\pm 0.5 \pm 0.20$

**Top mount type (TM type)**

**1) JC 1 Form A**

**CAD Data**

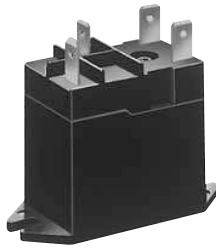

**External dimensions**

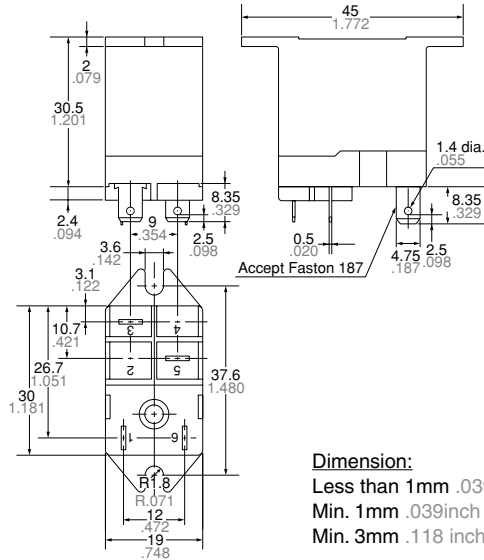

**Schematic**

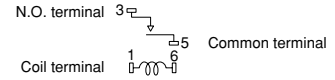

**Hole spacing**

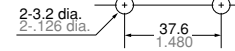

Tolerance:  $\pm 0.1 \pm .004$

**Dimension:**

Less than 1mm .039inch:

Min. 1mm .039inch less than 3mm .118 inch:

Min. 3mm .118 inch:

**General tolerance**

$\pm 0.2 \pm .008$

$\pm 0.3 \pm .012$

$\pm 0.5 \pm .020$

**2) JC 2 Form A**

**CAD Data**



**External dimensions**

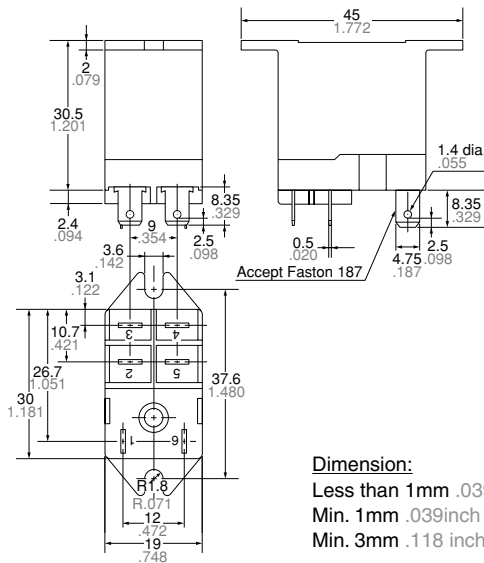

**Schematic (Bottom view)**

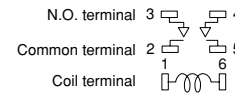

**Hole spacing**

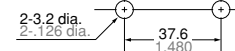

Tolerance:  $\pm 0.1 \pm .004$

**Dimension:**

Less than 1mm .039inch:

Min. 1mm .039inch less than 3mm .118 inch:

Min. 3mm .118 inch:

**General tolerance**

$\pm 0.2 \pm .008$

$\pm 0.3 \pm .012$

$\pm 0.5 \pm .020$

**SAFETY STANDARDS**

Item	UL/C-UL (Recognized)		CSA (Certified)		VDE (Certified)		TV rating (UL/CSA)		TÜV (Certified)		SEMKO (Certified)	
	File No.	Contact rating	File No.	Contact rating	File No.	Contact rating	File No.	Rating	File No.	Rating	File No.	Contact rating
1 Form A	E43028	15A 250V AC 15A 30V DC 1HP 125V AC 1HP 250V AC	LR26550 etc.	15A 250V AC 15A 30V DC 1HP 125V AC 1HP 250V AC	40016951 *1	10A 250V AC (cosφ=1.0) 7.5A 250V AC (cosφ=0.4) 10A 30V DC (0ms)	UL E43028 CSA LR26550	TV-8	B 08 07 13461 251	15A 250V AC (cosφ=1.0)	606466 *2	15/120A 250V AC
	E43028	10A 250V AC 10A 30V DC 1/2HP 125V AC 1/2HP 250V AC	LR26550 etc.	10A 250V AC 10A 30V DC 1/2HP 125V AC 1/2HP 250V AC	40016951 *1	5A 250V AC (cosφ=1.0) 3A 250V AC (cosφ=0.4) 5A 30V DC (0ms)	UL E43028 CSA LR26550 etc.	TV-5	B 08 07 13461 251	10A 250V AC (cosφ=1.0) 5A 50V DC (0ms)	606466 *2	5/40A 250V AC

Notes: \*1. Part numbers 1aF and 2aF are not VDE certified. Part numbers 1a and 2a are.  
\*2. Part numbers 1aF and 2aF are not SEMKO certified. Part numbers 1a and 2a are.

**For Cautions for Use.**