

64Mb Async and Burst CellularRAM 2.0

Overview

The IS66WVD4M16ALL is an integrated memory device containing 64Mbit Pseudo Static Random Access Memory using a self-refresh DRAM array organized as 4M words by 16 bits. The device uses a multiplexed address and data bus scheme to minimize pins and includes a industry standard burst mode for increased read and write bandwidth. The device includes several power saving modes : Reduced Array Refresh mode where data is retained in a portion of the array and Temperature Controlled Refresh. Both these modes reduce standby current drain. The device can be operated in a standard asynchronous mode and high performance burst mode. The die has separate power rails, VDDQ and VSSQ for the I/O to be run from a separate power supply from the device core.

Features

- Single device supports asynchronous and burst operation
- Mixed Mode supports asynchronous write and synchronous read operation
- Dual voltage rails for optional performance
 - VDD 1.7V~1.95V, VDDQ 1.7V~1.95V
- Multiplexed address and data bus
 - ADQ0~ADQ15
- Asynchronous mode read access : 70ns
- Burst mode for Read and Write operation
 - 4, 8, 16 or Continuous
- Low Power Consumption
 - Asynchronous Operation < 25 mA
 - Burst operation < 45 mA (@133Mhz)
 - Standby < 140 uA(max.)
 - Deep power-down (DPD) < 3uA (Typ)
- Low Power Feature
 - Reduced Array Refresh
 - Temperature Controlled Refresh
- Operation Frequency up to 133MHz
- Operating temperature Range
 - Industrial -40°C~85°C
- Package: 54-ball VFBGA

Copyright © 2010 Integrated Silicon Solution, Inc. All rights reserved. ISSI reserves the right to make changes to this specification and its products at any time without notice. ISSI assumes no liability arising out of the application or use of any information, products or services described herein. Customers are advised to obtain the latest version of this device specification before relying on any published information and before placing orders for products.

Integrated Silicon Solution, Inc. does not recommend the use of any of its products in life support applications where the failure or malfunction of the product can reasonably be expected to cause failure of the life support system or to significantly affect its safety or effectiveness. Products are not authorized for use in such applications unless Integrated Silicon Solution, Inc. receives written assurance to its satisfaction, that:

- a.) the risk of injury or damage has been minimized;
- b.) the user assume all such risks; and
- c.) potential liability of Integrated Silicon Solution, Inc is adequately protected under the circumstances

General Description

CellularRAM™ (Trademark of MicronTechnology) products are high-speed, CMOS pseudo-static random access memories developed for low-power, portable applications.

The 64Mb DRAM core device is organized as 4 Meg x 16 bits. This device is a variation of the industry-standard Flash control interface, with a multiplexed address/data bus.

The multiplexed address and data functionality dramatically reduce the required signal count, and increase READ/WRITE bandwidth.

To operate seamlessly on a burst Flash bus, CellularRAM products have incorporated a transparent self-refresh mechanism. The hidden refresh requires no additional support from the system memory controller and has no significant impact on device read/write performance.

Two user-accessible control registers define device operation. The bus configuration register (BCR) defines how the CellularRAM device interacts with the system memory bus and is nearly identical to its counterpart on burst mode Flash devices.

The refresh configuration register (RCR) is used to control how refresh is performed on the DRAM array. These registers are automatically loaded with default settings during power-up and can be updated anytime during normal operation.

Special attention has been focused on standby current consumption during self refresh. CellularRAM products include three mechanisms to minimize standby current. Partial array refresh (PAR) enables the system to limit refresh to only that part of the DRAM array that contains essential data. Temperature-compensated refresh (TCR) uses an on-chip sensor to adjust the refresh rate to match the device temperature — the refresh rate decreases at lower temperatures to minimize current consumption during standby.

Deep power-down (DPD) enables the system to halt the refresh operation altogether when no vital information is stored in the device. The system-configurable refresh mechanisms are adjusted through the RCR.

This CellularRAM device is compliant with the industry-standard CellularRAM 2.0 feature set established by the CellularRAM Workgroup. It includes support for both variable and fixed latency, with three drive strengths, a variety of wrap options, and a device ID register (DIDR).

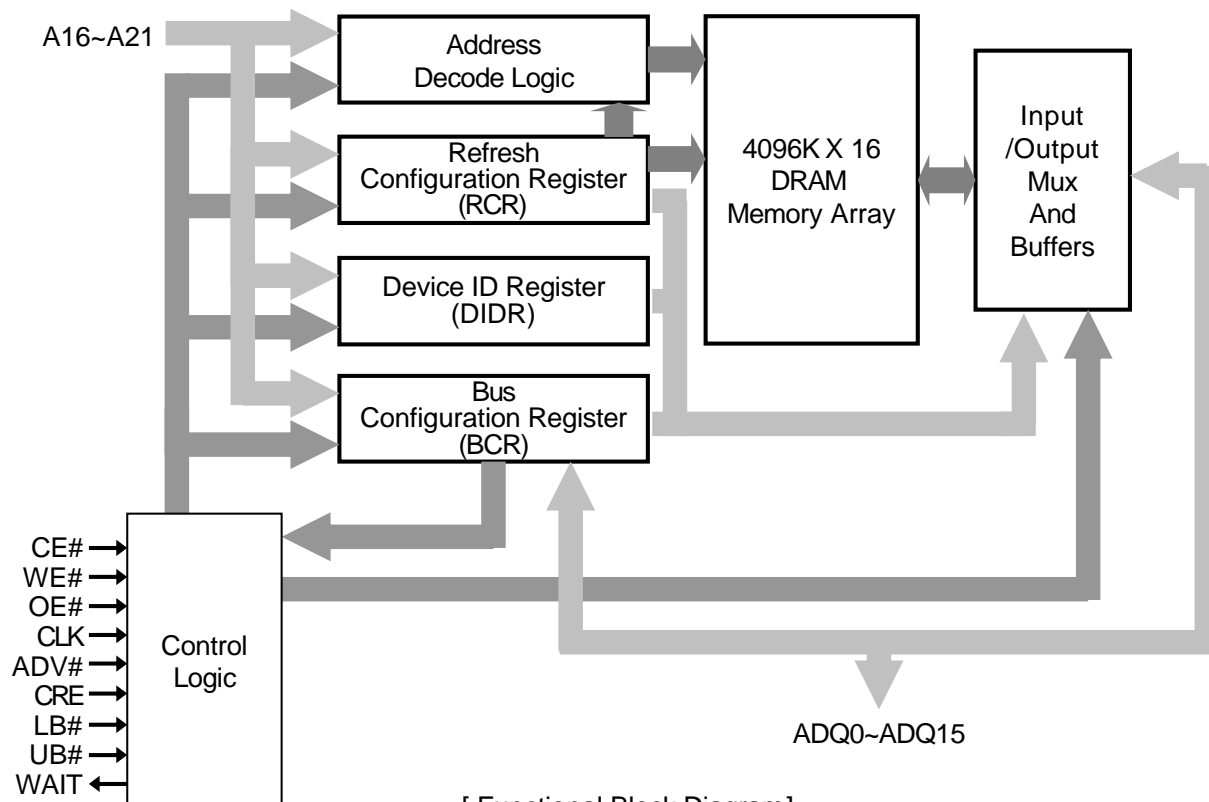

[Functional Block Diagram]

54Ball VFBGA Ball Assignment

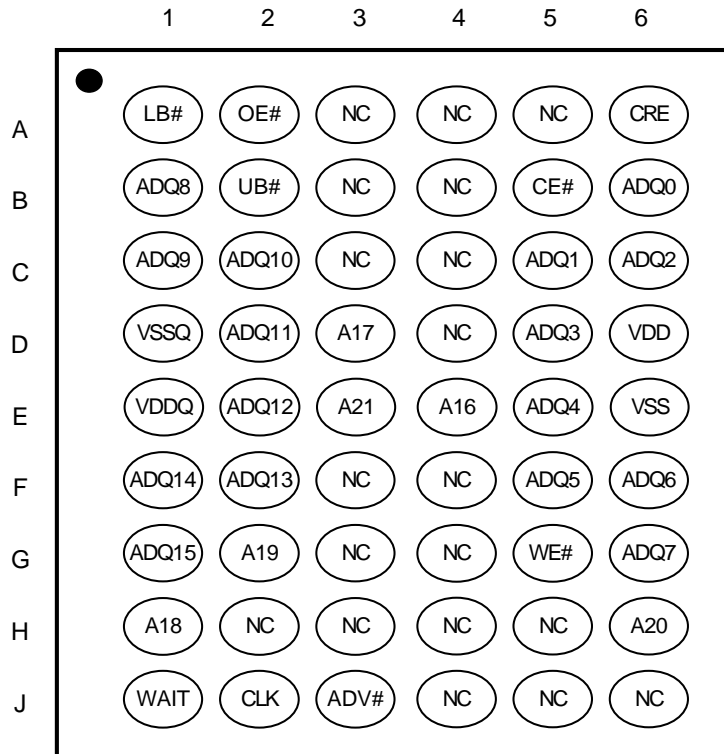

[Top View]
(Ball Down)

Signal Descriptions

All signals for the device are listed below in Table 1.











Table 1. Signal Descriptions

Symbol	Type	Description
VDD	Power Supply	Core Power supply (1.7V~1.95V)
VDDQ	Power Supply	I/O Power supply (1.7V~1.95V)
VSS	Power Supply	All VSS supply pins must be connected to Ground
VSSQ	Power Supply	All VSSQ supply pins must be connected to Ground
ADQ0~ADQ15	Input / Output	Address Input(A0~A15) Data Input/Output (DQ0~DQ15)
A16~A21	Input	Address Input(A16~A21)
LB#	Input	Lower Byte select
UB#	Input	Upper Byte select
CE#	Input	Chip Enable/Select
OE#	Input	Output Enable
WE#	Input	Write Enable
CRE	Input	Control Register Enable: When CRE is HIGH, READ and WRITE operations access registers.
ADV#	Input	Address Valid signal Signal that a valid address is present on the address bus. Address are latched on the rising edge of ADV# during asynchronous Read/Write operations. Addresses are latched on the rising edge of CLK with ADV# low during synchronous operation.
CLK	Input	Clock Latches addresses and commands on the first rising CLK edge when ADV# is active in synchronous mode. CLK must be kept static Low during asynchronous Read/Write operations.
WAIT	Output	WAIT Data valid signal during burst Read/Write operation. WAIT is used to arbitrate collisions between refresh and Read/Write operation. WAIT is also asserted at the end of a row unless wrapping within the burst length. WAIT is asserted and should be ignored during asynchronous READ operation. WAIT is gated by CE# and is high-Z when CE# is high.

Functional Description

All functions for the device are listed below in Table 2.

Table 2. Functional Descriptions

Mode	Power	CLK ¹	ADV#	CE#	OE#	WE#	CRE ²	UB#/ LB#	WAIT ³	ADQ [15:0] ⁴	Note
Asynchronous Mode											
Read	Active	L		L	L	H	L	L	Low-Z	Data-out	5
Write	Active	L		L	X	L	L	L	High-Z	Data-in	5
Standby	Stand by	L	X	H	X	X	L	X	High-Z	High-Z	6,7
No Operation	Idle	L	X	L	X	X	L	X	Low-Z	X	5,7
Configuration Register Write	Active	L		L	H	L	H	X	High-Z	High-Z	
Configuration Register Read	Active	L		L	L	H	H	L	Low-Z	Config-Reg Out	
Deep Power-Down	DPD	L	X	H	X	X	X	X	High-Z	High-Z	10
Synchronous Mode (Burst Mode)											
Async read	Active	L		L	L	H	L	L	Low-Z	Data-Out	5
Async write	Active	L		L	X	L	L	L	High-Z	Data-In	5
Standby	Stand by	L	X	H	X	X	L	X	High-Z	High-Z	6,7
No operation	Idle	L	X	L	X	X	L	X	Low-Z	X	5,8
Initial burst read	Active		L	L	X	H	L	L	Low-Z	Address	5,8
Initial burst write	Active		L	L	H	L	L	X	Low-Z	Address	5,8
Burst continue	Active		H	L	X	X	L	L	Low-Z	Data-In or Data-Out	5,8
Burst suspend	Active	L	L	L	H	X	L	X	Low-Z	High-Z	5,8
Configuration register write	Active		L	L	H	L	H	X	Low-Z	High-Z	8,11
Configuration register read	Active		L	L	L	H	H	L	Low-Z	Config-Reg Out	8,11
Deep Power-Down	DPD	L	X	H	X	X	X	X	High-Z	High-Z	10

Notes

1. CLK must be LOW during Asynch Read and Asynch Write modes. CLK must be LOW to achieve low standby current during standby mode and DPD modes. CLK must be static (LOW or HIGH) during burst suspend.
2. Configuration registers are accessed when CRE is HIGH during the address portion of a READ or WRITE cycle.
3. WAIT polarity is configured through the bus configuration register (BCR[10]).
4. When UB# and LB# are in select mode (LOW), ADQ0~ADQ15 are affected as shown. When only LB# is in select mode, ADQ0~ADQ7 are affected as shown. When only UB# is in select mode, ADQ8~ADQ15 are affected as shown.
5. The device will consume active power in this mode whenever addresses are changed with ADV# LOW
6. When the device is in standby mode, address inputs and data inputs/outputs are internally isolated from any external influence.
7. Vin=VDDQ or 0V, all device pins be static (unswitched) in order to achieve standby current.
8. Burst mode operation is initialized through the bus configuration register (BCR[15]).
9. Byte operation can be supported Write & Read at asynchronous mode and Write at synchronous mode.
10. DPD is initiated when CE# transition from LOW to HIGH after writing RCR[4] to 0. DPD is maintained until CE# transitions from HIGH to LOW
11. Initial cycle. Following cycles are the same as BURST CONTINUE. CE# must stay LOW for the equivalent of a single word burst (as indicated by WAIT).

Functional Description

In general, this device is high-density alternatives to SRAM and Pseudo SRAM products popular in low-power, portable applications.

The 64Mb device contains a 67,108,864-bit DRAM core organized as 4,194,304 addresses by 16 bits. This device implements a multiplexed address/data bus.

This multiplexed configuration supports greater bandwidth through a x16 data bus, yet still reduces the required signal count.

The CellularRAM bus interface supports both asynchronous and burst mode transfers.

Power-Up Initialization

CellularRAM products include an on-chip voltage sensor used to launch the power-up initialization process. Initialization will configure the BCR and the RCR with their default settings (see Table 3 and Table 8). VDD and VDDQ must be applied simultaneously.

When they reach a stable level at or above 1.7V, the device will require 150 μ s to complete its self-initialization process. During the initialization period, CE# should remain HIGH. When initialization is complete, the device is ready for normal operation.

Figure 1: Power-Up Initialization Timing

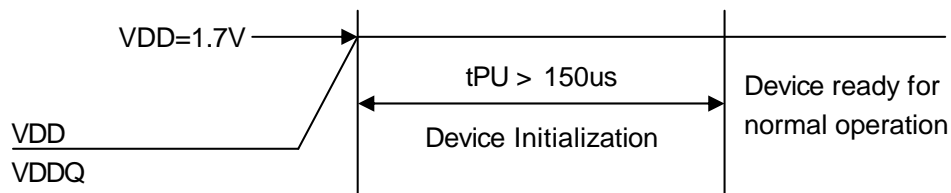

Bus Operating Modes

CellularRAM products incorporate a burst mode interface targeted at low-power, wireless applications. This bus interface supports asynchronous and burst mode read and write transfers. The specific interface supported is defined by the value loaded into the bus configuration register.

Burst Mode Operation

Burst mode operations enable high-speed synchronous READ and WRITE operations. Burst operations consist of a multi-clock sequence that must be performed in an ordered fashion.

The size of a burst can be specified in the BCR either as a fixed length or continuous. Fixed-length bursts consist of four, eight, or sixteen words of sixteen bits. Continuous bursts have the ability to start at a specified address and burst to the end of the row. (Row length of 128 words or 256 words is a manufacturer option.)

The latency count stored in the BCR defines the number of clock cycles that elapse before the initial data value is transferred between the processor and CellularRAM device. The initial latency for READ operations can be configured as fixed or variable. Variable latency allows the CellularRAM to be configured for minimum latency at high clock frequencies, but the controller must monitor WAIT to detect any conflict with refresh cycles (see Figure 23).

Fixed latency outputs the first data word after the worst-case access delay, including allowance for refresh collisions. The initial latency time and clock speed determine the latency count setting. Fixed latency is used when the controller cannot monitor WAIT. Fixed latency also provides improved performance at lower clock frequencies.

The WAIT output asserts when a burst is initiated and de-asserts to indicate when data is to be transferred into (or out of) the memory. WAIT will again be asserted at the boundary of the row unless wrapping within the burst length.

To access other devices on the same bus without the timing penalty of the initial latency for a new burst, burst mode can be suspended. Bursts are suspended by stopping CLK. CLK must be stopped LOW. If another device will use the data bus while the burst is suspended, OE# should be taken HIGH to disable the CellularRAM outputs; otherwise, OE# can remain LOW. Note that the WAIT output will continue to be active, and as a result no other devices should directly share the WAIT connection to the controller. To continue the burst sequence, OE# is taken LOW, then CLK is restarted after valid data is available on the bus.

CE# LOW time is limited by refresh considerations. CE# must not stay LOW longer than tCEM. If a burst suspension will cause CE# to remain LOW for longer than tCEM, CE# should be taken HIGH and the burst restarted with a new CE# LOW/ADV# LOW cycle.

Burst Read Operation

After CE# goes LOW, the address to access is latched on the rising edge of the next clock that ADV# is LOW. During this first clock rising edge, WE# indicates whether the operation is going to be a READ (WE# = HIGH, Figure 2)

Then the data needs to be output to multiplexed data bus (ADQ0~ADQ15) according to set WAIT states.

The WAIT output asserts when a burst is initiated, and de-asserts to indicate when data is to be transferred into (or out of) the memory. WAIT will again be asserted at the boundary of a row, unless wrapping within the burst length.

A full 4 word synchronous read access is shown in Figure 2 and the AC characteristics are specified in Table 16.

Figure 2. Synchronous Read Access Timing

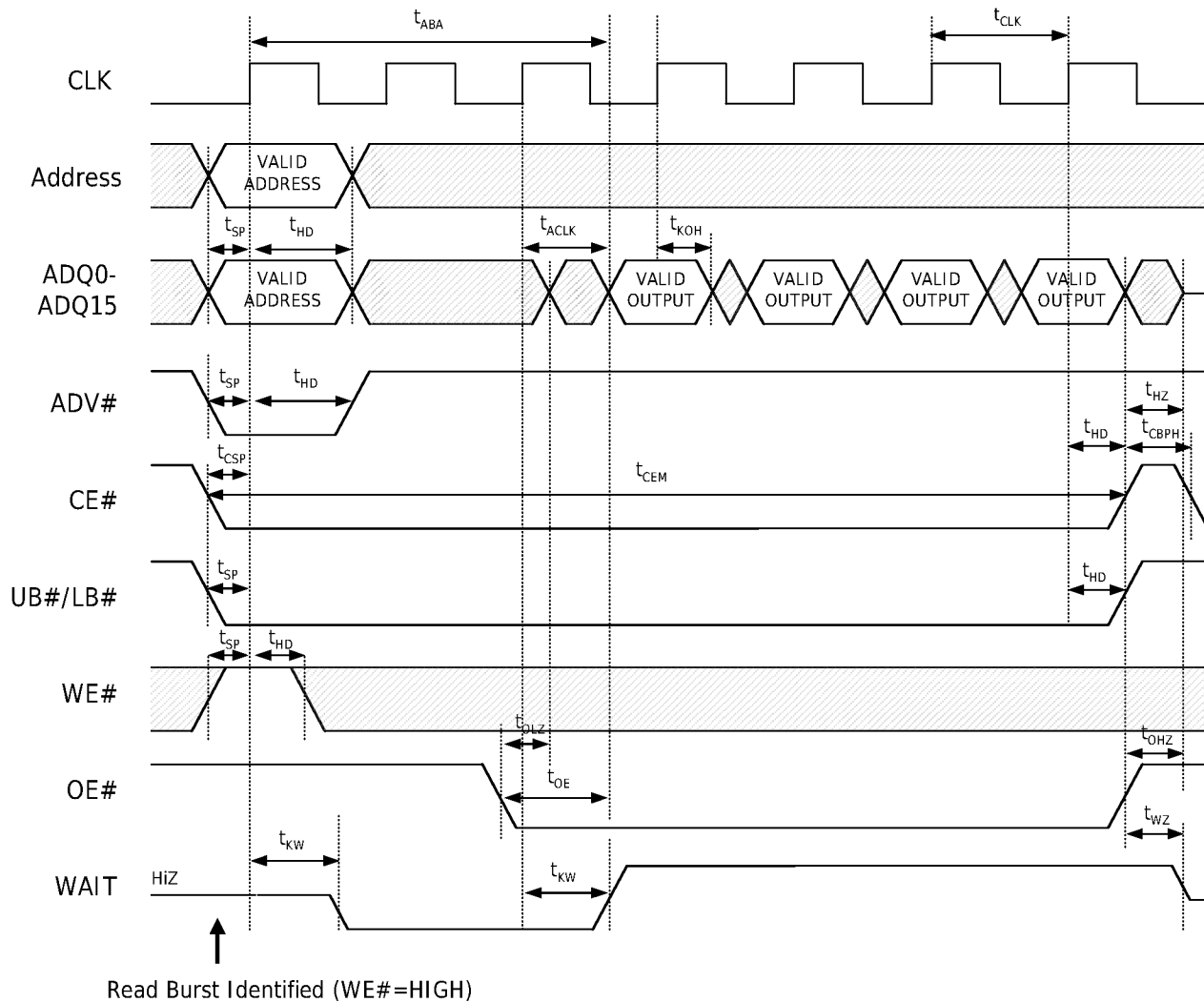

Burst Write Operation

After CE# goes LOW, the address to access is latched on the rising edge of the next clock that ADV# is LOW. During this first clock rising edge, WE# indicates whether the operation is going to be a WRITE (WE# =LOW, Figure 3).

Data is placed to the multiplexed data bus (ADQ0~ADQ15) with consecutive clock cycles when WAIT de-asserts.

The WAIT output asserts when a burst is initiated, and de-asserts to indicate when data is to be transferred into (or out of) the memory. WAIT will again be asserted at the boundary of a row, unless wrapping within the burst length.

A full 4 word synchronous write access is shown in Figure 3 and the AC characteristics are specified in Table 18.

Figure 3. Synchronous Write Access Timing

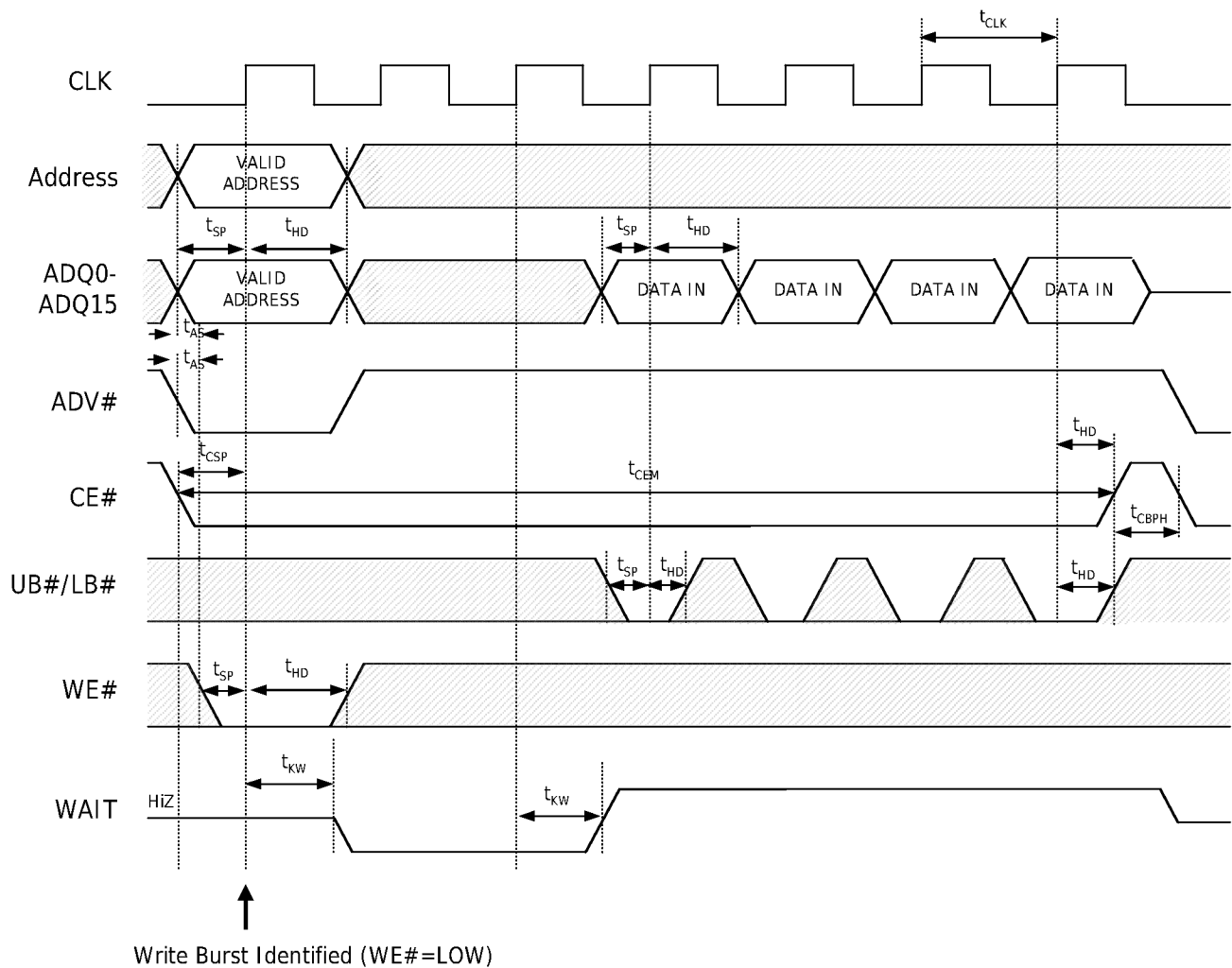

Asynchronous Mode

Asynchronous mode uses industry-standard SRAM control signals (CE#, ADV#, OE#, WE#, UB#, and LB#). READ operations (Figure 4) are initiated by bringing CE#, ADV#, UB# and LB# LOW while keeping OE# and WE# HIGH, and driving the address onto the multiplexed address/data bus. ADV# is taken HIGH to capture the address, and OE# is taken LOW. Valid data will be driven out of the I/Os after the specified access time has elapsed.

WRITE operations (Figure 5) occur when CE#, ADV#, WE#, UB#, and LB# are driven LOW with the address on the multiplexed address/data bus. ADV# is taken HIGH to capture the address, then the write data is driven onto the bus. During asynchronous WRITE operations, the OE# level is a "Don't Care," and WE# will override OE#; however, OE# must be HIGH while the address is driven onto the ADQ bus. The data to be written is latched on the rising edge of CE#, WE#, UB#, and LB# (whichever occurs first).

During asynchronous operation, the CLK input must be held LOW. WAIT will be driven during asynchronous READs, and its state should be ignored. WE# must not be held LOW longer than t_{CEM}.

Figure 4. Asynchronous Read Access Timing

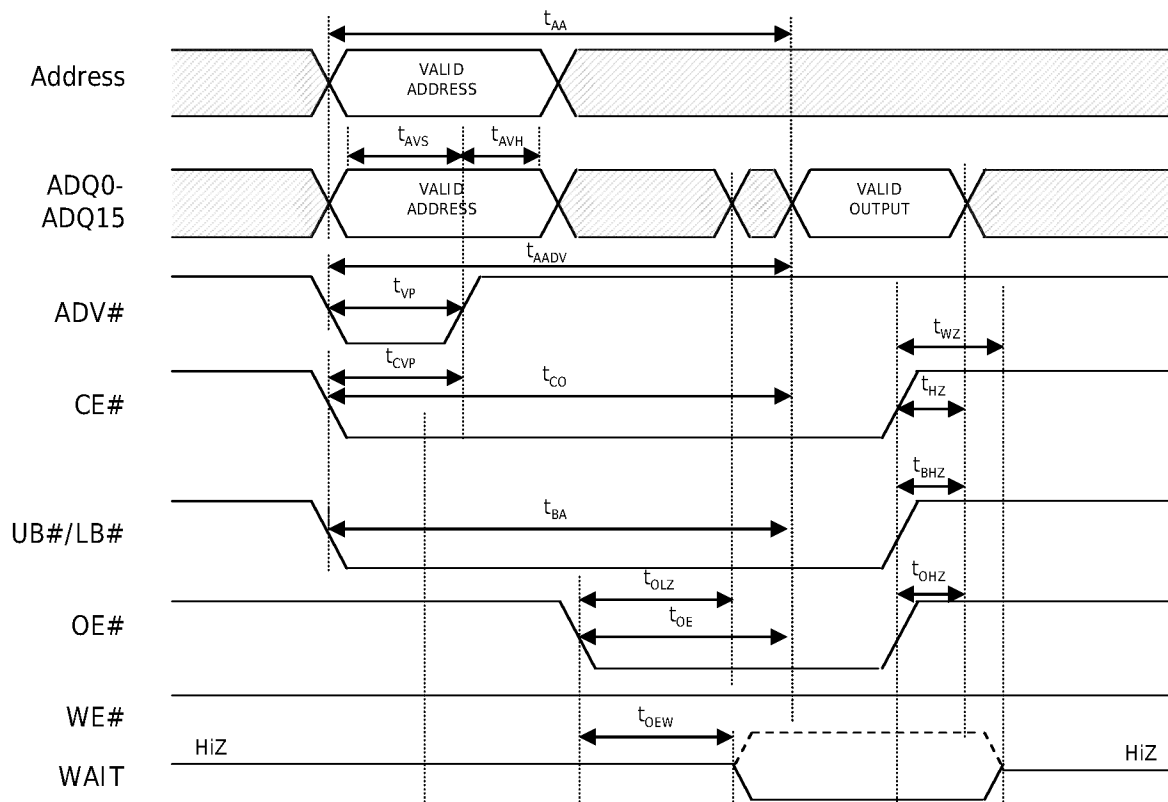
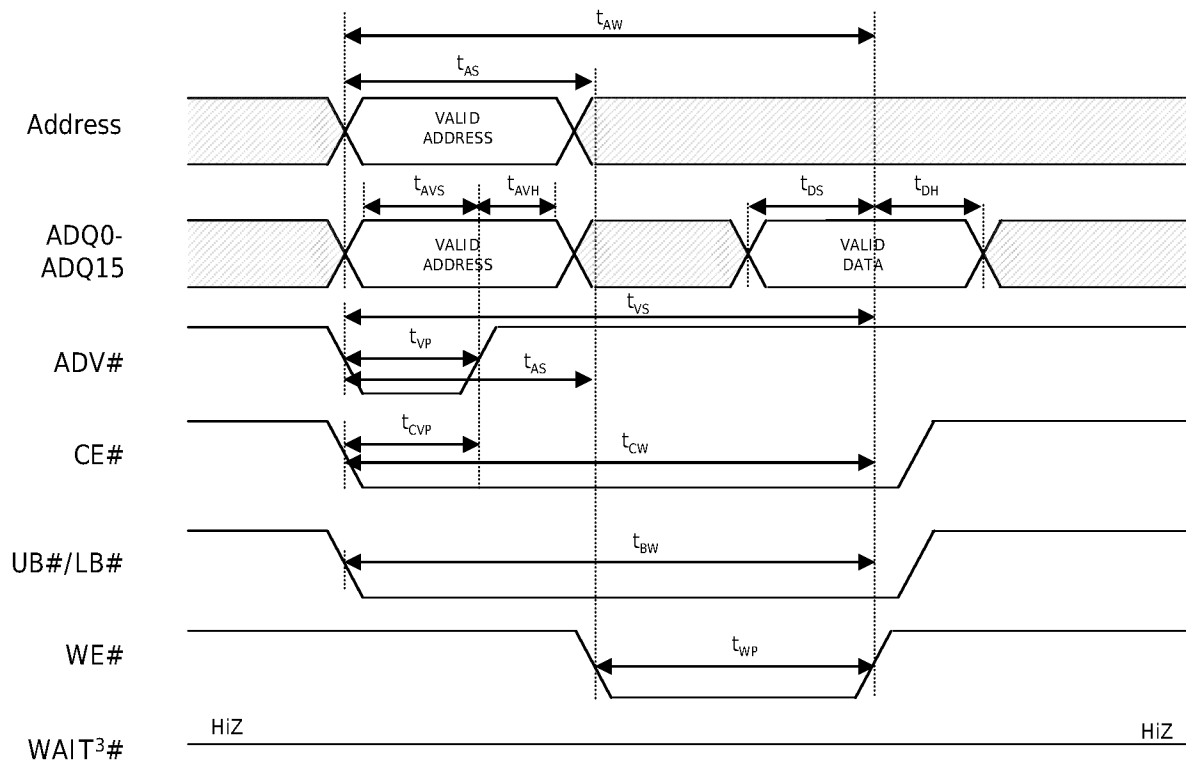

Figure 5. Asynchronous Write Access Timing

Mixed-Mode Operation

The device can support a combination of synchronous READ and asynchronous READ and WRITE operations when the BCR is configured for synchronous operation. The asynchronous READ and WRITE operations require that the clock (CLK) remain LOW during the entire sequence. The ADV# latches the target address. CE# can remain LOW when transitioning between mixed-mode operations with fixed latency enabled; however, the CE# LOW time must not exceed tCEM. Mixed-mode operation facilitates a seamless interface to legacy burst mode Flash memory controllers. See Figure 33 for the “Asynchronous WRITE Followed by Burst READ” timing diagram.

WAIT Operation

WAIT output on the CellularRAM device is typically connected to a shared, system-level WAIT signal. The shared WAIT signal is used by the processor to coordinate transactions with multiple memories on the synchronous bus.

When a synchronous READ or WRITE operation has been initiated, WAIT goes active to indicate that the CellularRAM device requires additional time before data can be transferred. For READ operations, WAIT will remain active until valid data is output from the device. For WRITE operations, WAIT will indicate to the memory controller when data will be accepted into the CellularRAM device. When WAIT transitions to an inactive state, the data burst will progress on successive rising clock edges.

During a burst cycle CE# must remain asserted until the first data is valid. Bringing CE# HIGH during this initial latency may cause data corruption.

When using variable initial access latency (BCR[14] = 0), the WAIT output performs an arbitration role for READ operations launched while an on-chip refresh is in progress. If a collision occurs, the WAIT pin is asserted for additional clock cycles until the refresh has completed (see Figure 23). When the refresh operation has completed, the READ operation will continue normally.

WAIT will be asserted but should be ignored during asynchronous READ operations.

WAIT will be High-Z during asynchronous WRITE operations.

By using fixed initial latency (BCR[14] = 1), this CellularRAM device can be used in burst mode without monitoring the WAIT pin. However, WAIT can still be used to determine when valid data is available at the start of the burst and at the end of the row. If wait is not monitored, the controller must stop burst accesses at row boundaries on its own.

UB#/LB# Operation

The UB#/LB# enable signals support byte-wide data WRITES. During WRITE operations, any disabled bytes will not be transferred to the RAM array and the internal value will remain unchanged. During an asynchronous WRITE cycle, the data to be written is latched on the rising edge of CE#, WE#, UB#, and LB# whichever occurs first.

UB#/LB# must be LOW during READ cycles.

When UB#/LB# are disabled (HIGH) during an operation, the device will disable the data bus from receiving or transmitting data. Although the device will seem to be deselected, it remains in an active mode as long as CE# remains LOW.

Low-Power Feature

Standby Mode Operation

During standby, the device current consumption is reduced to the level necessary to perform the DRAM refresh operation. Standby operation occurs when CE# is HIGH. The device will enter a reduced power state upon completion of a READ or WRITE operation, or when the address and control inputs remain static for an extended period of time. This mode will continue until a change occurs to the address or control inputs.

Temperature-Compensated Refresh

Temperature-compensated refresh (TCR) allows for adequate refresh at different temperatures. This CellularRAM device includes an on-chip temperature sensor that automatically adjusts the refresh rate according to the operating temperature. The device continually adjusts the refresh rate to match that temperature.

Partial-Array Refresh

Partial-array refresh (PAR) restricts refresh operation to a portion of the total memory array. This feature enables the device to reduce standby current by refreshing only that part of the memory array required by the host system. The refresh options are full array, one-half array, one-quarter array, one-eighth array, or none of the array. The mapping of these partitions can start at either the beginning or the end of the address map (see Table 9). READ and WRITE operations to address ranges receiving refresh will not be affected. Data stored in addresses not receiving refresh will become corrupted. When re-enabling additional portions of the array, the new portions are available immediately upon writing to the RCR.

Deep Power-Down Operation

Deep power-down (DPD) operation disables all refresh-related activity. This mode is used if the system does not require the storage provided by the CellularRAM device. Any stored data will become corrupted when DPD is enabled. When refresh activity has been re-enabled, the CellularRAM device will require 150 μ s to perform an initialization procedure before normal operations can resume. During this 150 μ s period, the current consumption will be higher than the specified standby levels, but considerably lower than the active current specification.

DPD can be enabled by writing to the RCR using CRE or the software access sequence; DPD starts when CE# goes HIGH. DPD is disabled the next time CE# goes LOW.

Registers

Two user-accessible configuration registers define the device operation. The bus configuration register (BCR) defines how the CellularRAM interacts with the system memory bus and is nearly identical to its counterpart on burst mode Flash devices. The refresh configuration register (RCR) is used to control how refresh is performed on the DRAM array. These registers are automatically loaded with default settings during power-up, and can be updated any time the devices are operating in a standby state. A DIDR provides information on the device manufacturer, CellularRAM generation, and the specific device configuration. The DIDR is read-only.

Access Using CRE

The registers can be accessed using either a synchronous or an asynchronous operation when the configuration register enable (CRE) input is HIGH (see Figures 6 through 9). When CRE is LOW, a READ or WRITE operation will access the memory array. The register values are written as an address (ADV# LOW) on the ADQ pins. In an asynchronous WRITE, the values are latched into the configuration register on the rising edge of CE# or WE#, whichever occurs first; UB#/LB# are "Don't Care." The BCR is accessed when A[19:18] is 10b; the RCR is accessed when A[19:18] is 00b; the DIDR is accessed when A[19:18] is 01b. For READs, address inputs other than A[19:18] are "Don't Care," and register bits are output as data (ADV# HIGH) on ADQ.

Figure 6: Configuration Register WRITE
- Asynchronous Mode Followed by READ ARRAY Operation

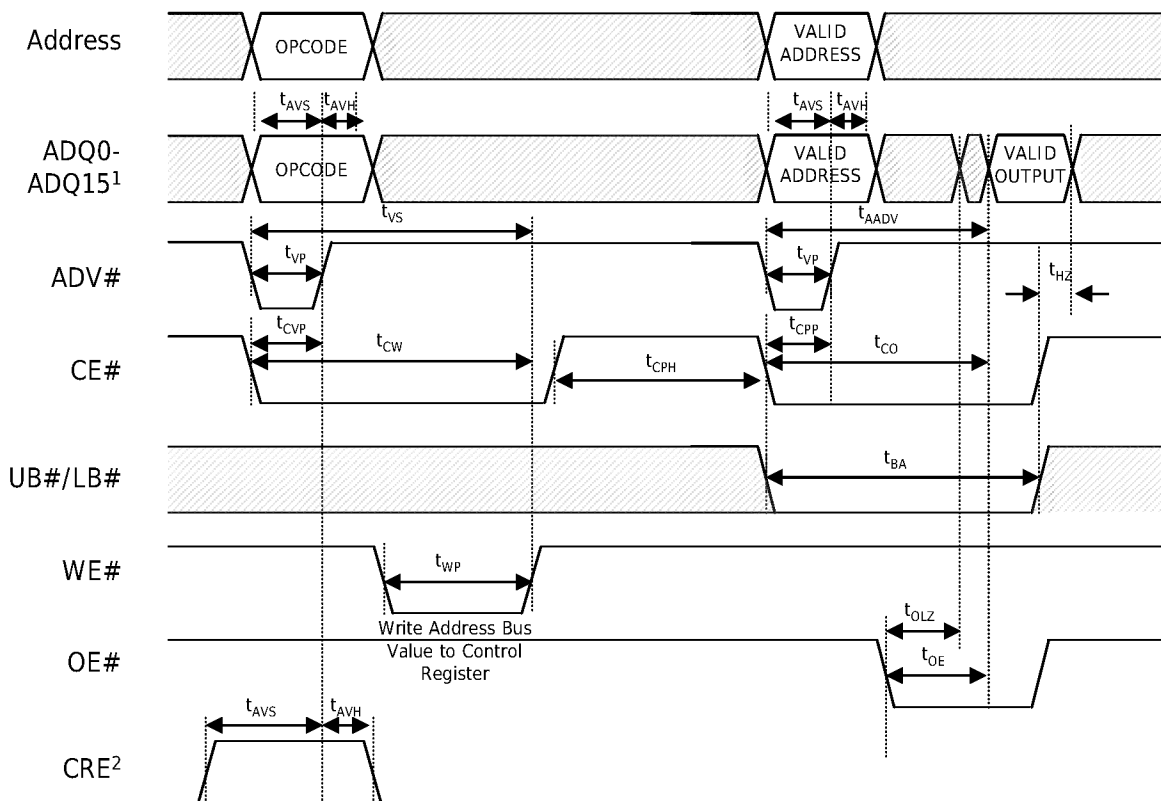

Notes:

1. A[19:18] = 00b to load RCR ADQ[15:0]; 10b to load BCR ADQ[15:0].
2. CRE must be HIGH to access registers.

**Figure 7: Configuration Register WRITE
 - Synchronous Mode Followed by READ ARRAY Operation**

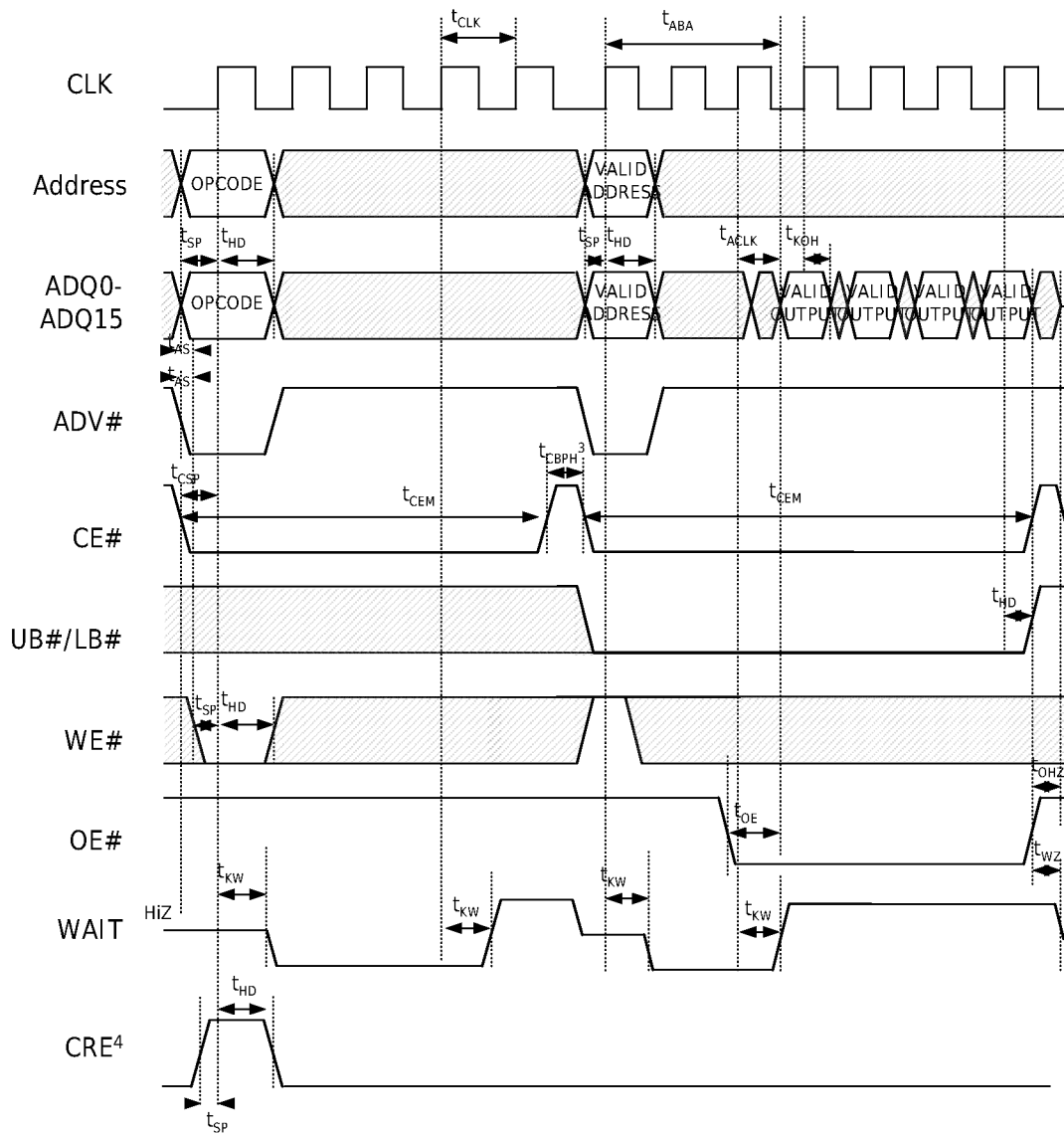

Notes:

1. Non-default BCR settings for configuration register WRITE in synchronous mode, followed by READ ARRAY operation: Latency code three (four clocks); WAIT active LOW; WAIT asserted during delay.
2. A[19:18] = 00b to load RCR ADQ[15:0]; 10b to load BCR ADQ[15:0].
3. CE# must remain LOW to complete a burst-of-one WRITE. WAIT must be monitored additional WAIT cycles caused by refresh collisions require a corresponding number of additional CE# LOW cycles.
4. CRE must be HIGH to access registers.

Figure 8: Configuration Register READ
- Asynchronous Mode Followed by DATA READ

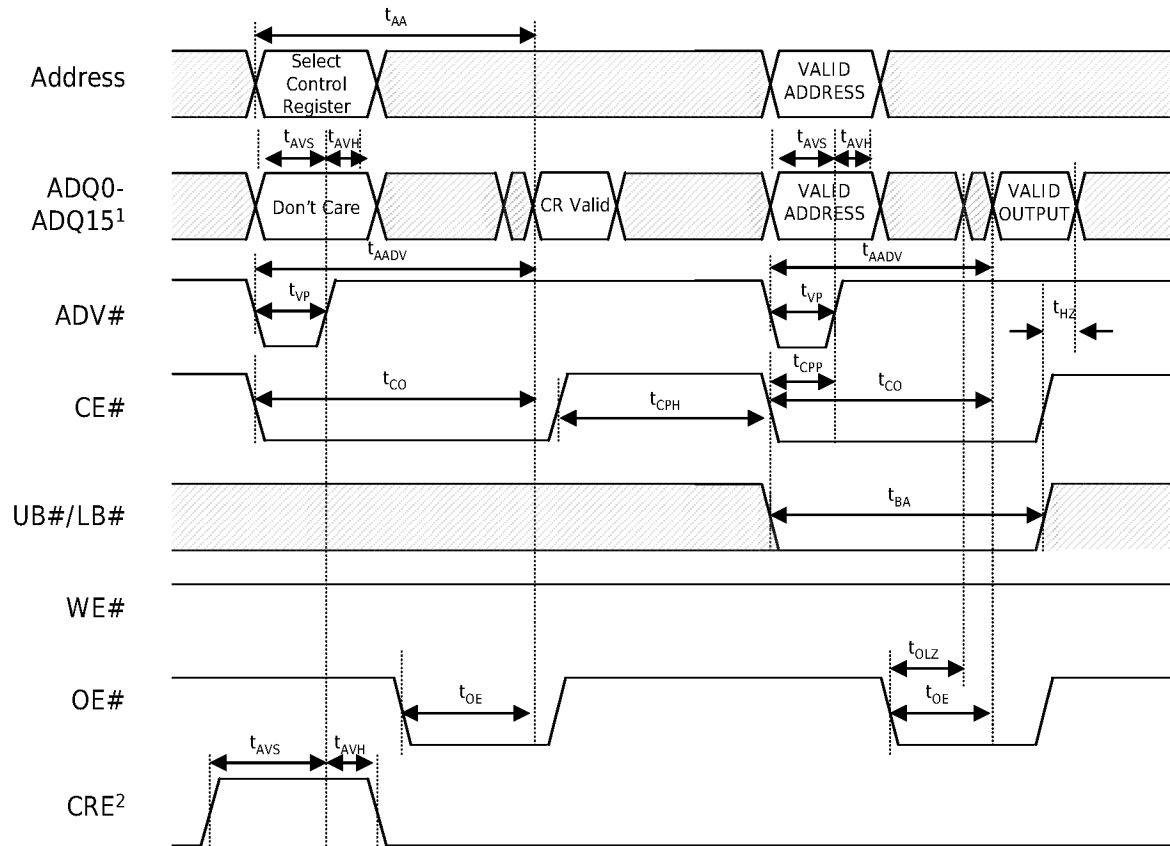

Notes:

1. A[19:18] = 00b to load RCR ADQ[15:0]; 10b to load BCR ADQ[15:0]; 01b to load DIDR ADQ[15:0].
2. CRE must be HIGH to access registers.

Figure 9: Configuration Register READ
- Synchronous Mode Followed by Data READ

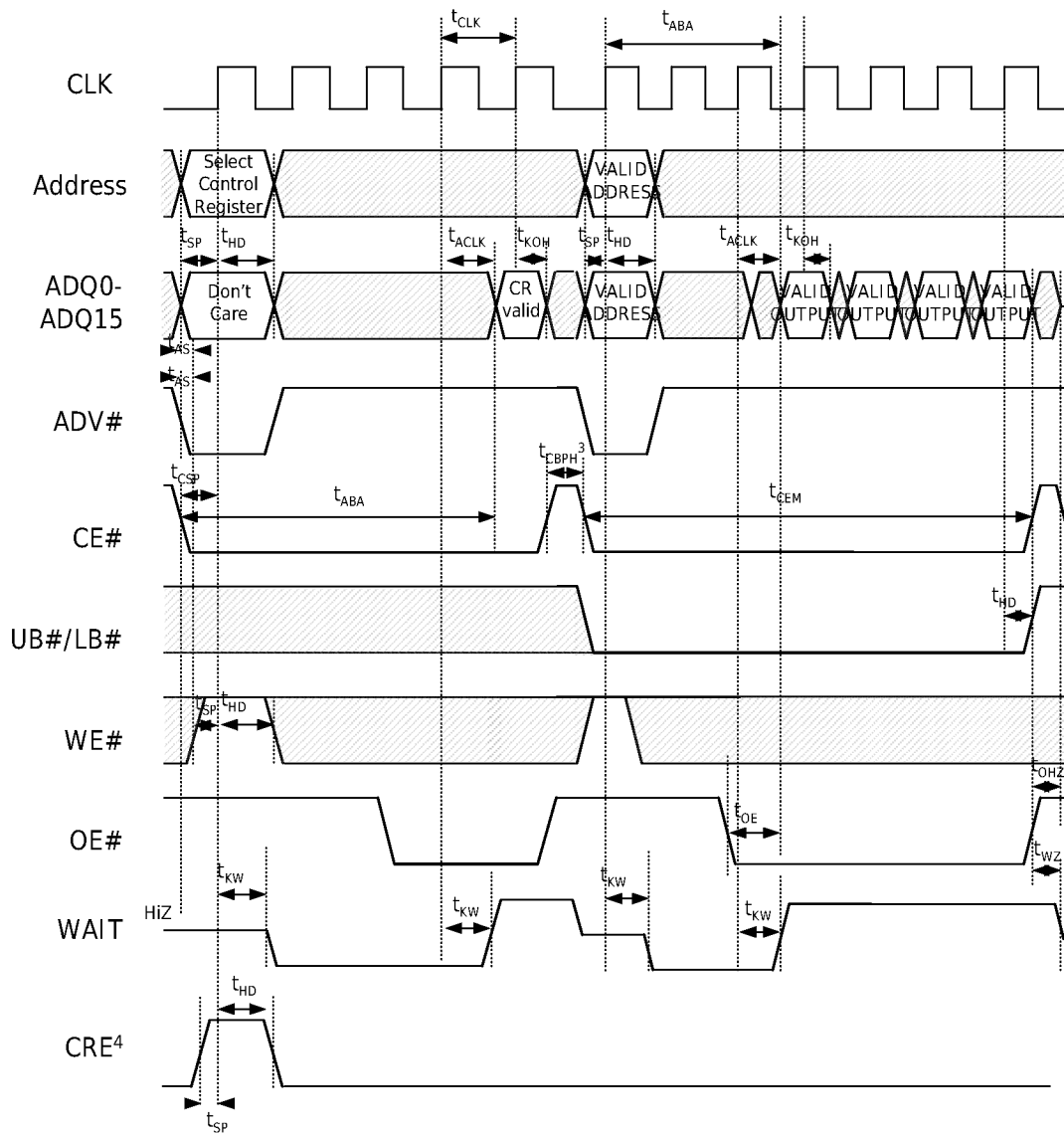

Notes:

1. Non-default BCR settings for configuration register READ in synchronous mode, followed by READ ARRAY operation: Latency code two (three clocks); WAIT active LOW; WAIT asserted during delay.
2. A[19:18] = 00b to load RCR ADQ[15:0]; 10b to load BCR ADQ[15:0]; 01b to load DIDR ADQ[15:0].
3. CE# must remain LOW to complete a burst-of-one READ. WAIT must be monitored additional WAIT cycles caused by refresh collisions require a corresponding number of additional CE# LOW cycles.
4. CRE must be HIGH to access registers.

Software Access Sequence

Software access of the configuration registers uses a sequence of asynchronous READ and asynchronous WRITE operations. The contents of the configuration registers can be read or modified using the software sequence.

The configuration registers are loaded using a four-step sequence consisting of two asynchronous READ operations followed by two asynchronous WRITE operations (see Figure 11). The read sequence is virtually identical except that an asynchronous READ is performed during the fourth operation (see Figure 10). The address used during all READ and WRITE operations is the highest address of the CellularRAM device being accessed (3FFFFFFh); the contents of this address are not changed by using this sequence. The data value presented during the third operation (WRITE) in the sequence defines whether the BCR or the RCR is to be accessed. If the data is 0000h, the sequence will access the RCR; if the data is 0001h, the sequence will access the BCR; if the data is 0002h, the sequence will access the DIDR. During the fourth operation, ADQ[15:0] transfer data into or out of bits 15:0 of the control registers.

The use of the software sequence does not affect the ability to perform the standard (CRE-controlled) method of loading the configuration registers. However, the software nature of this access mechanism eliminates the need for the control register enable (CRE) pin. If the software mechanism is used, the CRE pin can simply be tied to VSS. The port line often used for CRE control purposes is no longer required.

Figure 10 : Configuration Register Read

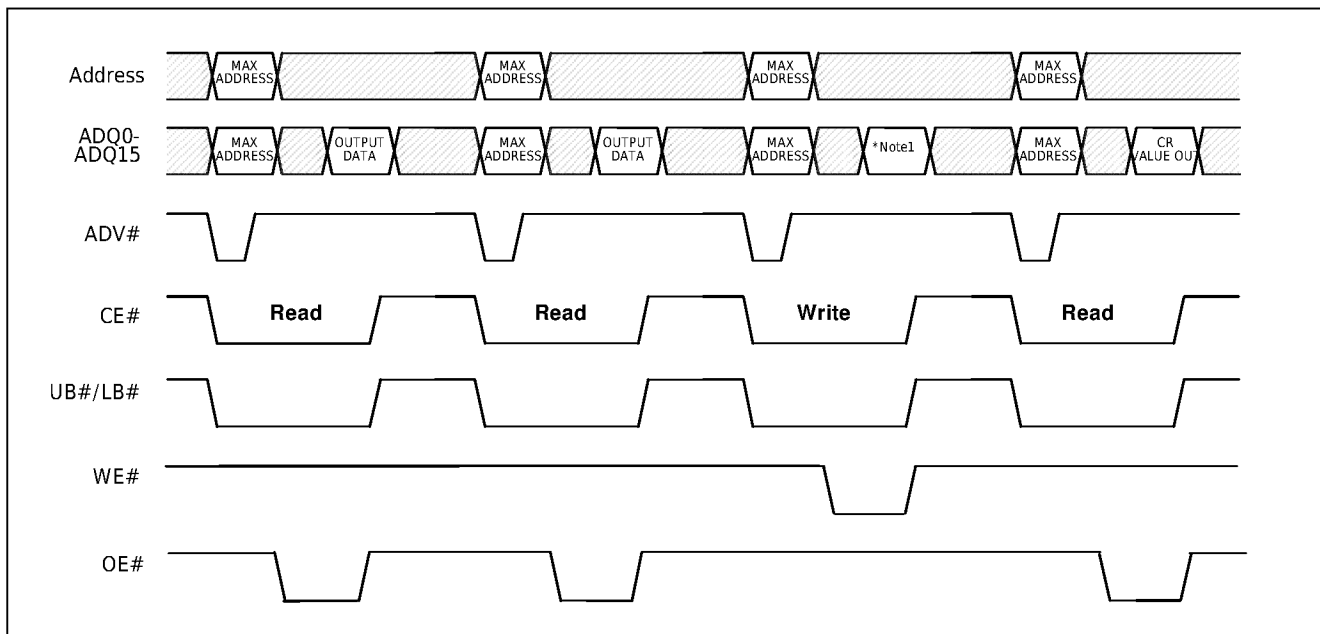

Notes :

1. RCR : 0000h , BCR : 0001h , DIDR : 0002h

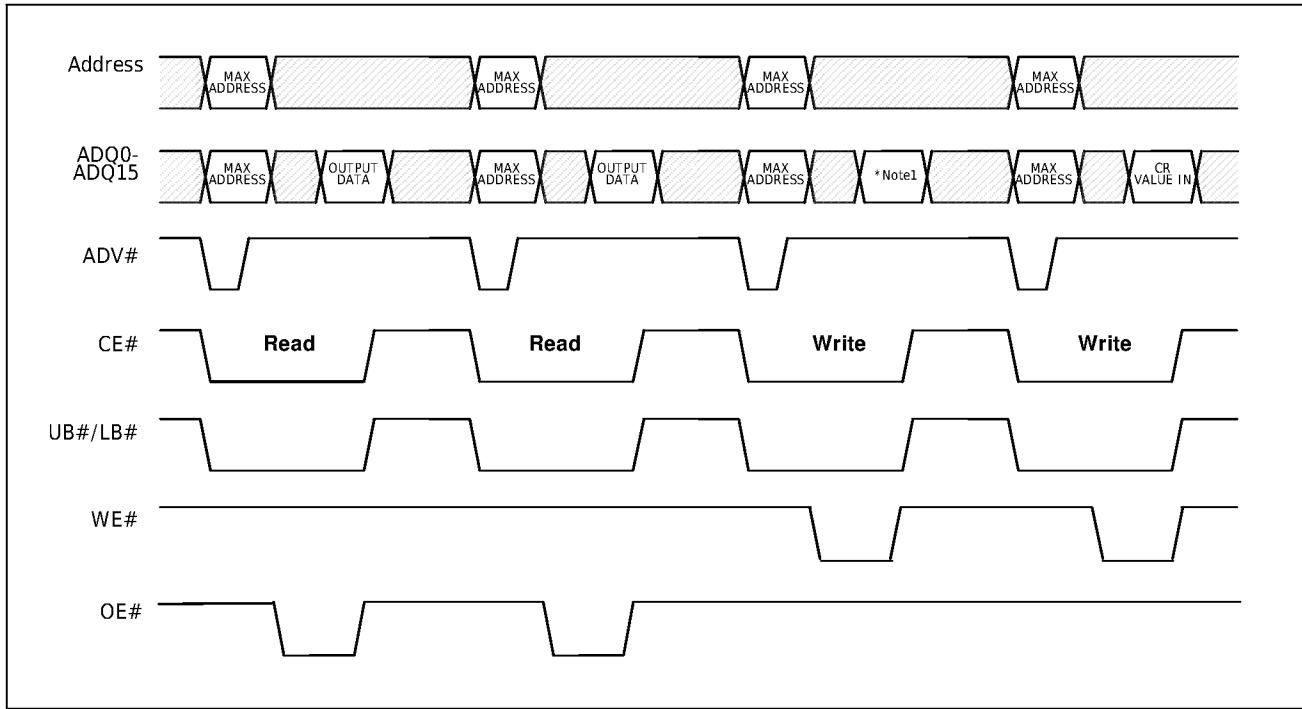
Figure 11 : Configuration Register Write

Notes :

1. RCR : 0000h , BCR : 0001h

Bus Configuration Register

The BCR defines how the CellularRAM device interacts with the system memory bus. Table 3 describes the control bits in the BCR. At power-up, the BCR is set to 1D1Fh. The BCR is accessed using CRE and A[19:18] = 10b, or through the configuration register software sequence with ADQ[15:0] = 0001h on the third cycle.

Table 3. Bus configuration Register

Bit Number	Definition	Remark
21-20	Reserved	Must be set to "0"
19 - 18	Register Select	00 = Select RCR 01 = Select DIDR 10 = Select BCR
17 - 16	Reserved	Must be set to "0"
15	Operating mode	0 = Synchronous burst access mode (default) 1 = Asynchronous access mode
14	Initial Latency	0 = Variable (default) 1 = Fixed
13 - 11	Latency Count	000 = 9 clock cycles 001 = reserved 010 = 3 clock cycles 011 = 4 clock cycles (default) 100 = 5 clock cycles 101 = 6 clock cycles 110 = 7 clock cycles 111 = reserved
10	WAIT Polarity	0 = Active LOW : Data valid at WAIT HIGH 1 = Active HIGH : Data valid at WAIT LOW (default)
9	Reserved	Must be set to "0"
8	WAIT Configuration	0 = Asserted during delay 1 = Asserted one data cycle before delay (default)
7 - 6	Reserved	Must be set to "0"
5 - 4	Output Impedance	00 = Full drive 01 = ½ Drive (default) 10 = ¼ Drive 11 = Reserved
3	Burst mode	0 = Burst wrap within the burst length 1 = Burst no wrap (default)
2 - 0	Burst Length	001 = 4 words 010 = 8 words 011 = 16 words 111 = continuous (default) Others = Reserved

Notes :

1. Burst wrap and length apply to both READ and WRITE operations.

Burst Length (BCR[2:0]) Default = Continuous Burst

Burst lengths define the number of words the device outputs during burst READ and WRITE operations. The device supports a burst length of four, eight, or sixteen words of sixteen bits. The device can also be set in continuous burst mode where data is accessed sequentially up to the end of the row.

Burst Wrap (BCR[3]) Default = No Wrap

The burst-wrap option determines if a 4-, 8-, or 16-word READ or WRITE burst wraps within the burst length, or steps through sequential addresses if continuous burst operation is selected in BCR[2:0]. If the wrap option is not enabled, the device accesses data from sequential addresses up to the end of the row.

Table 4. Sequence and Burst Length

Starting Address	Wrap	BL4	BL8	BL16	Continuous
DEC	BCR[3]	Linear	Linear	Linear	Linear
0	"0" Wrap	0-1-2-3	0-1-2-3-4-5-6-7	0-1-2-3- ... -12-13-14-15	0-1-2-3-4-5-6- ...
1		1-2-3-0	1-2-3-4-5-6-7-0	1-2-3-4- ... -13-14-15-0	1-2-3-4-5-6-7- ...
2		2-3-0-1	2-3-4-5-6-7-0-1	2-3-4-5- ... -14-15-0-1	2-3-4-5-6-7-8- ...
3		3-0-1-2	3-4-5-6-7-0-1-2	3-4-5-6- ... -15-0-1-2	3-4-5-6-7-8-9- ...
...	
6		6-7-4-5	6-7-0-1-2-3-4-5	6-7-8-9- ... -2-3-4-5	6-7-8-9-10-11-12- ...
7		7-4-5-6	7-0-1-2-3-4-5-6	7-8-9-10- ... -3-4-5-6	7-8-9-10-11-12-13- ...
...	
14		14-15-12-13	14-15-8-9-10-11-12-13	14-15-0-1- ... -10-11-12-13	14-15-16-17-18-19-20- ...
15		15-12-13-14	15-8-9-10-11-12-13-14	15-0-1-2-3- ... -11-13-13-14	15-16-17-18-19-20-21- ...
...	
254		254-255-252-253	254-255-248-249-250-251-252-253	254-255-240-241- ... -250-251-252-253	254-255-0-1-2-...
255		255-252-253-254	255-248-249-250-251-252-253-254	255-240-241-242- ... -251-252-253-254	255-0-1-2-...
0		"1" No Wrap	0-1-2-3	0-1-2-3-4-5-6-7	0-1-2-3-4- ... -12-13-14-15
1	1-2-3-4		1-2-3-4-5-6-7-8	1-2-3-4- ... -13-14-15-16	1-2-3-4-5-6-7- ...
2	2-3-4-5		2-3-4-5-6-7-8-9	2-3-4-5- ... -14-15-16-17	2-3-4-5-6-7-8- ...
3	3-4-5-6		3-4-5-6-7-8-9-10	3-4-5-6- ... -15-16-17-18	3-4-5-6-7-8-9- ...
...
6	6-7-8-9		6-7-8-9-10-11-12-13	6-7-8-9- ... -18-19-20-21	6-7-8-9-10-11-12- ...
7	7-8-9-10		7-8-9-10-11-12-13-14	7-8-9-10- ... -19-20-21-22	7-8-9-10-11-12-13- ...
...
14	14-15-16-17		14-15-16-17-18-19-20-21	14-15-16-17- ... -26-27-28-29	14-15-16-17-18-19-20- ...
15	15-16-17-18		15-16-17-18-19-20-21-22	15-16-17-18- ... -27-28-29-30	15-16-17-18-19-20-21- ...
...
254	254-255		254-255	254-255	254-255
255	255		255	255	255

Drive Strength (BCR[5:4]) Default = Outputs Use Half-Drive Strength

The output driver strength can be altered to full, one-half, or one-quarter strength to adjust for different data bus loading scenarios. The reduced-strength options are intended for stacked chip (Flash + CellularRAM) environments when there is a dedicated memory bus. The reduced-drive-strength option minimizes the noise generated on the data bus during READ operations. Full output drive strength should be selected when using a discrete CellularRAM device in a more heavily loaded data bus environment. Outputs are configured at half-drive strength during testing. See Table 5.

Table 5. Drive Strength

BCR[5]	BCR[4]	Drive Strength	Impedance Typ (Ω)	Use Recommendation
0	0	Full	25 ~ 30	CL = 30pF to 50pF
0	1	1/2(Default)	50	CL = 15pF to 30pF 104MHz at light load
1	0	1/4	100	CL = 15pF or lower
1	1	Reserved		

WAIT Configuration (BCR[8]) Default = WAIT Transitions One Clock Before Data Valid/ Invalid

The WAIT configuration bit is used to determine when WAIT transitions between the asserted and the de-asserted state with respect to valid data presented on the data bus. The memory controller will use the WAIT signal to coordinate data transfer during synchronous READ and WRITE operations. When BCR[8] = 0, data will be valid or invalid on the clock edge immediately after WAIT transitions to the de-asserted or asserted state respectively. When BCR[8] = 1, the WAIT signal transitions one clock period prior to the data bus going valid or invalid (see Figure 12).

Figure 12. WAIT Configuration During Burst Operation

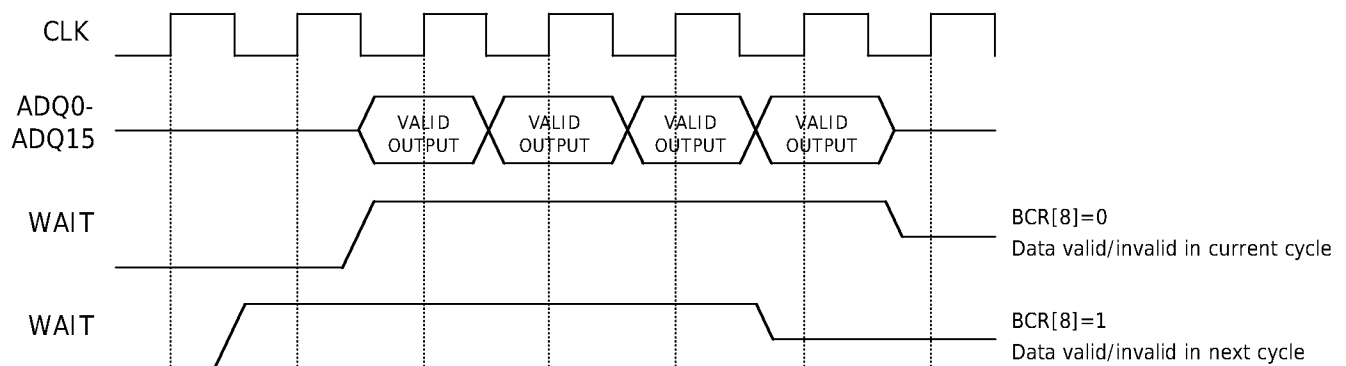

Notes : Non-default BCR setting : WAIT active LOW

WAIT Polarity (BCR[10]) Default = WAIT Active HIGH

The WAIT polarity bit indicates whether an asserted WAIT output should be HIGH or LOW. This bit will determine whether the WAIT signal requires a pull-up or pull-down resistor to maintain the de-asserted state.

Latency Counter (BCR[13:11]) Default = Three Clock Latency

The latency counter bits determine how many clocks occur between the beginning of a READ or WRITE operation and the first data value transferred. Latency codes from two (three clocks) to six (seven clocks) and eight (nine clocks) are supported (see Tables 6 and 7, Figure 13, and Figure 14).

Initial Access Latency (BCR[14]) Default = Variable

Variable initial access latency outputs data after the number of clocks set by the latency counter. However, WAIT must be monitored to detect delays caused by collisions with refresh operations.

Fixed initial access latency outputs the first data at a consistent time that allows for worst-case refresh collisions. The latency counter must be configured to match the initial latency and the clock frequency. It is not necessary to monitor WAIT with fixed initial latency. The burst begins after the number of clock cycles configured by the latency counter. (See Table 6 and Figure 13)

Table 6. Variable Latency Configuration Codes (BCR[14] = 0)

BCR [13:11]	Latency Configuration Code	Latency		Max Input CLK Frequency (MHz)		
		Normal	Refresh Collision	-75	-96	-12
010	2 (3 clocks)	2	4	66 (15.0ns)	66 (15.0ns)	52 (18.5ns)
011	3 (4 clocks)-default	3	6	104 (9.62ns)	104 (9.62ns)	80 (12.5ns)
100	4 (5 clocks)	4	8	133 (7.5ns)		
others	Reserved	-	-	-	-	-

Notes:

1. Latency is the number of clock cycles from the initialization of a burst operation until data appears. Data is transferred on the next clock cycle. READ latency can range from the normal latency to the value shown for refresh collision.

Figure 13. Latency Counter (Variable Latency, No Refresh Collision)

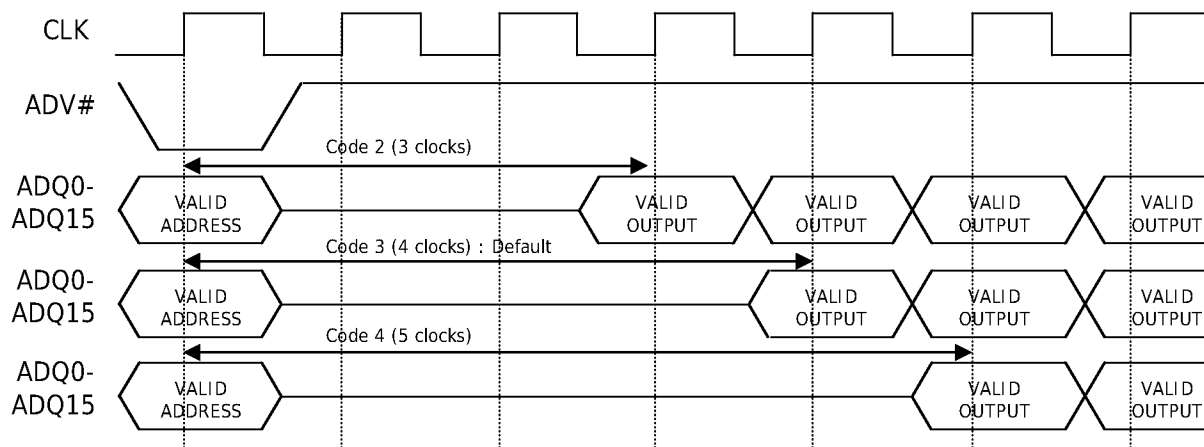
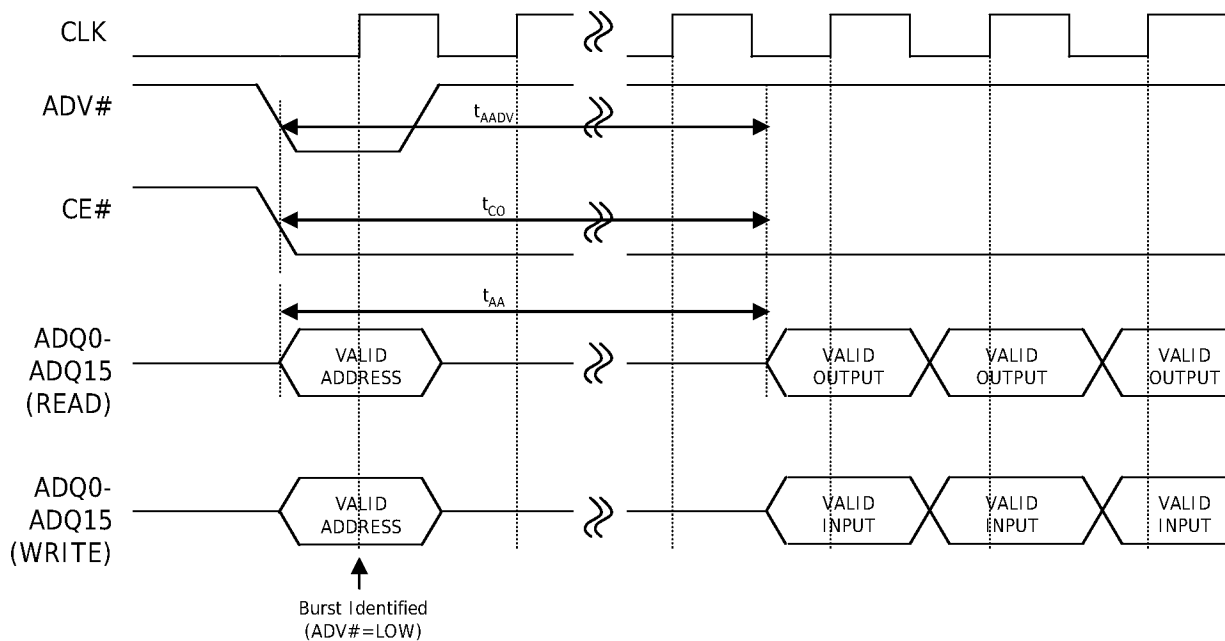

Table 7. Fixed Latency Configuration Codes (BCR[14] = 1)

BCR [13:11]	Latency Configuration Code	Latency Count (N)	Max Input CLK Frequency (MHz)		
			-75	-96	-12
010	2 (3 clocks)	2	33 (30ns)	33 (30ns)	25 (40ns)
011	3 (4 clocks)-default	3	52 (19.2ns)	52 (19.2ns)	40 (25ns)
100	4 (5 clocks)	4	66 (15ns)	66 (15.0ns)	52 (19.2ns)
101	5 (6 clocks)	5	75 (13.3ns)	75 (13.3ns)	66 (15.0ns)
110	6 (7 clocks)	6	104 (9.62ns)	104 (9.62ns)	80 (12.5ns)
000	8 (9 clocks)	8	133 (7.5ns)	-	-
others	Reserved	-	-	-	-

Figure 14. Latency Counter (Fixed Latency)

Operating Mode (BCR[15]) Default = Synchronous Operation

The operating mode bit enables synchronous burst operation or limits the device to the asynchronous mode of operation only. If the clock is stopped LOW, all accesses are asynchronous, even when synchronous mode is enabled.

Refresh Configuration Register

The refresh configuration register (RCR) defines how the CellularRAM device performs its transparent self refresh. Altering the refresh parameters can dramatically reduce current consumption during standby mode. Table 8 describes the control bits used in the RCR.

The RCR is accessed using CRE and A[19:18] = 00b, or through the configuration register software access sequence with ADQ = 0000h on the third cycle (see "Registers")

Table 8. Refresh Configuration Register

Bit Number	Definition	Remark
21-20	Reserved	Must be set to "0"
19 - 18	Register Select	00 = Select RCR 01 = Select DIDR 10 = Select BCR
17 - 7	Reserved	Must be set to "0"
6 - 5	Reserved	Setting is ignored
4	DPD	0 = DPD enable 1 = DPD disable (default)
3	Reserved	Must be set to "0"
2 - 0	Partial Refresh	000 = Full array (default) 001 = Bottom 1/2 array 010 = Bottom 1/4 array 011 = Bottom 1/8 array 100 = None of array 101 = Top 1/2 array 110 = Top 1/4 array 111 = Top 1/8 array

Partial-Array Refresh (RCR[2:0]) Default = Full Array Refresh

The PAR bits restrict refresh operation to a portion of the total memory array. This feature allows the device to reduce standby current by refreshing only that part of the memory array required by the host system. The refresh options are full array, one-half array, one-quarter array, one-eighth array, or none of the array. The mapping of these partitions can start at either the beginning or the end of the address map (see Tables 9)

Table 9. 64Mb Address Patterns for PAR (RCR[4]=1)

RCR[2]	RCR[1]	RCR[0]	Active Section	Address Space	Size	Density
0	0	0	Full	000000h ~ 3FFFFFFh	4MX16	64Mb
0	0	1	Bottom 1/2 array	000000h ~ 1FFFFFFh	2MX16	32Mb
0	1	0	Bottom 1/4 array	000000h ~ 0FFFFFFh	1MX16	16Mb
0	1	1	Bottom 1/8 array	000000h ~ 07FFFFh	512KX16	8Mb
1	0	0	None of array	0		0Mb
1	0	1	Top 1/2 array	200000h ~ 3FFFFFFh	2MX16	32Mb
1	1	0	Top 1/4 array	300000h ~ 3FFFFFFh	1MX16	16Mb
1	1	1	Top 1/8 array	380000h ~ 3FFFFFFh	512KX16	8Mb

Deep Power-Down (RCR[4]) Default = DPD Disabled

The deep power-down bit enables and disables all refresh-related activity. This mode is used if the system does not require the storage provided by the CellularRAM device. Any stored data will become corrupted when DPD is enabled. When refresh activity has been re-enabled, the CellularRAM device will require 150µs to perform an initialization procedure before normal operations can resume.

Deep power-down is enabled by setting RCR[4] = 0 and taking CE# HIGH. Taking CE# LOW disables DPD and sets RCR[4] = 1; it is not necessary to write to the RCR to disable DPD. DPD can be enabled using CRE or the software sequence to access the RCR. BCR and RCR values (other than BCR[4]) are preserved during DPD.

Device Identification Register

The DIDR provides information on the device manufacturer, CellularRAM generation, and the specific device configuration. Table 10 describes the bit fields in the DIDR. This register is read-only.

The DIDR is accessed with CRE HIGH and A[19:18] = 01b, or through the software access sequence with ADQ = 0002h on the third cycle.

Table 10. Device Identification Register Mapping

Bit Field	DIDR[15]		DIDR[14:11]		DIDR[10:8]		DIDR[7:5]		DIDR[4:0]	
Field Name	Row Length		Device Version		Device Density		CellularRAM Generation		Vendor ID	
	Length - words	Bit Setting	Version	Bit Setting	Density	Bit Setting	Generation	Bit Setting	Vendor	Bit Setting
	128	0b	1st	0000b	64Mb	010b	CR1.5	010b	ISSI	00101b
	256	1b	2nd	0001b	128Mb	011b	CR2.0	011b		

Electrical Characteristics

Table 11. Absolute Maximum Ratings

Parameter	Rating
Voltage to Any Ball Except VDD, VDDQ Relative to VSS	-0.3V to VDDQ + 0.3V
Voltage on VDD Supply Relative to VSS	-0.2V to + 2.45V
Voltage on VDDQ Supply Relative to VSS	-0.2V to + 2.45V
Storage Temperature (plastic)	-55°C to + 150°C
Operating Temperature (case)	-40°C to + 85°C
Soldering Temperature and Time : 10s (solder ball only)	+ 260°C

Notes:

Stresses greater than those listed may cause permanent damage to the device. This is a stress rating only, and functional operation of the device at these or any other conditions above those indicated in this specification is not implied. Exposure to absolute maximum rating conditions for extended periods may affect reliability.

Table 12. Electrical Characteristics and Operating Conditions

Industrial Temperature (-40°C < TC < +85°C)

Description	Conditions	Symbol		MIN	MAX	Unit	Note
Supply Voltage		VDD		1.7	1.95	V	
I/O Supply Voltage		VDDQ		1.7	1.95	V	
Input High Voltage		VIH		VDDQ-0.4	VDDQ+0.2	V	1
Input Low Voltage		VIL		-0.20	0.4	V	2
Output High Voltage	IOH = -0.2mA	VOH		0.80 VDDQ		V	3
Output Low Voltage	IOL = +0.2mA	VOL			0.20 VDDQ	V	3
Input Leakage Current	VIN = 0 to VDDQ	ILI			1	uA	
Output Leakage Current	OE# = VIH or Chip Disabled	ILO			1	uA	
Operating Current	Conditions	Symbol		TYP	MAX	Unit	Note
Asynchronous Random READ/WRITE	VIN = VDDQ or 0V Chip enabled, IOUT = 0	IDD1	-70		25	mA	4
Initial Access, Burst READ/WRITE		IDD2	133Mhz		45	mA	4
			104Mhz		35		
			80Mhz		30		
Continuous Burst READ		IDD3R	133Mhz		40	mA	4
			104Mhz		30		
			80Mhz		25		
Continuous Burst WRITE		IDD3W	133Mhz		40	mA	4
			104Mhz		35		
			80Mhz		30		
Standby Current	VIN = VDDQ or 0V CE# = VDDQ	ISB			140	uA	5

Notes:

1. Input signals may overshoot to $VDDQ + 1.0V$ for periods less than 2ns during transitions.
2. Input signals may undershoot to $VSS - 1.0V$ for periods less than 2ns during transitions.
3. $BCR[5:4] = 01b$ (default setting of one-half drive strength).
4. This parameter is specified with the outputs disabled to avoid external loading effects.
User must add required current to drive output capacitance expected in the actual system.
5. ISB (MAX) values measured with PAR set to FULL ARRAY at $+85^{\circ}C$. In order to achieve low standby current, all inputs must be driven to either $VDDQ$ or VSS . ISB might be set slightly higher for up to 500ms after power-up, or when entering standby mode.

Table 13. Deep Power-Down Specifications

Description	Conditions	Symbol	TYP	MAX	Unit
Deep Power-Down	$VIN=VDDQ$ or $0V$ $VDD, VDDQ=1.95V, +85^{\circ}C$	I_{DPD}	3	10	μA

Notes:

Typical (TYP) I_{DPD} value applies across all operating temperatures and voltages.

Table 14. Capacitance

Description	Conditions	Symbol	MIN	MAX	Unit	Note
Input Capacitance	$T_C=+25^{\circ}C$; $f=1MHz$; $VIN=0V$	C_{IN}	2.0	6.0	pF	1
Input/Output Capacitance (ADQ)		C_{IO}	3.0	6.5	pF	1

Notes:

1. These parameters are verified in device characterization and are not 100% tested.

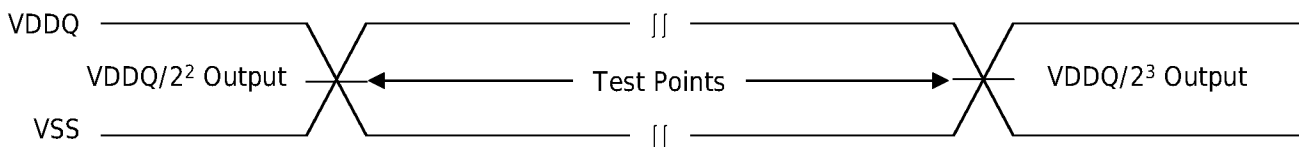
Figure 15. AC Input/ Output Reference Waveform

Notes:

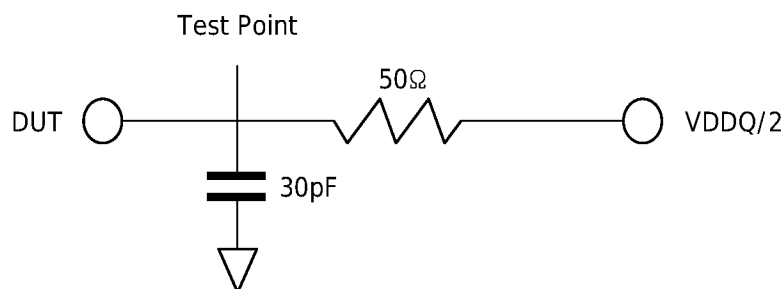
1. AC test inputs are driven at $VDDQ$ for a logic 1 and VSS for a logic 0. Input rise and fall times (10% to 90%) $< 1.6ns$.
2. Input timing begins at $VDDQ/2$.
3. Output timing ends at $VDDQ/2$.

Figure 16. Output Load Circuit

Notes:

All tests are performed with the outputs configured for default setting of half drive strength ($BCR[5:4] = 01b$).

AC Characteristics

Table15 . Asynchronous READ Cycle Timing Requirements

Symbol	Parameter	-70		Unit	Notes
		Min	Max		
t_{AA}	Address Access Time		70	ns	
t_{AADV}	ADV# Access Time		70	ns	
t_{AVH}	Address hold from ADV# HIGH	2		ns	
t_{AVS}	Address setup to ADV# HIGH	5		ns	
t_{BA}	UB#, LB# Access Time		70	ns	1
t_{BHZ}	UB#, LB# Disable to High-Z Output		7		
t_{CPH}	CE# HIGH between Subsequent Asynchronous cycles	5		ns	
t_{CO}	Chip Select Access Time		70	ns	
t_{CVP}	CE# low to ADV# HIGH	7		ns	
t_{HZ}	Chip Disable to High-Z Output		7		1
t_{OE}	OE# low to Valid Output		20	ns	
t_{OEW}	OE# low to WAIT Valid	1	7.5		
t_{OHZ}	OE# high to High-Z Output		7	ns	1
t_{OLZ}	OE# low to Low-Z output	3		ns	2
t_{VP}	ADV# Low pulse width	7		ns	
t_{WZ}	CE# high to WAIT High-Z		7	ns	1

Notes:

1. Low-Z to High-Z timings are tested with the circuit shown in Figure 23. The High-Z timings measure a 100mV transition from either VOH or VOL toward VDDQ/2.
2. High-Z to Low-Z timings are tested with the circuit shown in Figure 23. The Low-Z timings measure a 100mV transition away from the High-Z (VDDQ/2) level toward either VOH or VOL.

Table16 . Burst READ Cycle Timing Requirements

Symbol	Parameter	-7013		-7010		-7008		Unit	Note
		Min	Max	Min	Max	Min	Max		
t_{AA}	Address Access Time (Fixed Latency)		70		70		70	ns	
t_{AADV}	ADV# Access Time (Fixed Latency)		70		70		70	ns	
t_{ABA}	Burst to READ Access Time (Variable Latency)		35.5		35.9		46.5	ns	
t_{ACLK}	CLK to Output Delay		5.5		7		9	ns	1
t_{CBPH}	CE# High between Subsequent Burst or Mixed-Mode Operations	5		5		6		ns	2
t_{CEM}	Maximum CE# Pulse width		4		4		4	us	2
t_{CLK}	CLK Period	7.5		9.62		12.5		ns	
t_{CO}	Chip Select Access Time (Fixed Latency)		70		70		70	ns	
t_{CSP}	CE# Setup Time to Active CLK Edge	2.5		3		4		ns	
t_{HD}	Hold Time from Active CLK Edge	2		2		2		ns	
t_{HZ}	Chip Disable to High-Z Output		7		7		7	ns	3
t_{KH}/t_{KL}	CLK HIGH or LOW Time	3		3		4		ns	
t_{KOH}	Output Hold from CLK	2		2		2		ns	
t_{KW}	CLK to WAIT Valid		5.5		7		9	ns	1
t_{OE}	Burst OE# LOW to Output Valid		20		20		20	ns	
t_{OHZ}	OE# high to High-Z Output		7		7		7	ns	4
t_{OLZ}	OE# low to Low-Z output	3		3		3		ns	4
t_{SP}	Setup time to Active CLK Edge	2		3		3		ns	
t_T	CLK Rise or Fall Time		1.2		1.6		1.8	ns	
t_{WZ}	CE# high to WAIT High-Z		7		7		7	ns	3

Notes:

1. t_{ACLK} and t_{KW} values for -7013 are for variable LC = 4 and fixed LC = 8 only. For other LC settings, these parameters will be 7ns for -7013 devices.
2. A refresh opportunity must be provided every t_{CEM} by taking CE# HIGH.
3. Low-Z to High-Z timings are tested with the circuit shown in Figure 16.
The High-Z timings measure a 100mV transition from either VOH or VOL toward VDDQ/2.
4. High-Z to Low-Z timings are tested with the circuit shown in Figure 16.
The Low-Z timings measure a 100mV transition away from the High-Z (VDDQ/2) level toward either VOH or VOL.

Table17 . Asynchronous WRITE Cycle Timing Requirements

Symbol	Parameter	-70		Unit	Notes
		Min	Max		
t_{AS}	Address and ADV# LOW Setup Time	0		ns	
t_{AVH}	Address hold from ADV# HIGH	2		ns	
t_{AVS}	Address setup to ADV# HIGH	5		ns	
t_{AW}	Address Valid to End of Write	70		ns	
t_{BW}	UB#, LB# Select to End of Write	70		ns	
t_{CPH}	CE# HIGH between Subsequent Asynchronous cycles	5		ns	
t_{CVP}	CE# low to ADV# HIGH	7		ns	
t_{CW}	Chip Enable to End of Write	70			
t_{DH}	Data Hold from Write Time	0		ns	
t_{DS}	Data Write Setup Time	20			
t_{VP}	ADV# Low pulse width	7		ns	
t_{VS}	ADV# Setup to End of Write	70		ns	
t_{WHZ}	WRITE to ADQ High-Z Output		7	ns	
t_{WP}	WRITE Pulse Width	45		ns	1
t_{WR}	WRITE Recovery Time	0		ns	
t_{WZ}	CE# high to WAIT High-Z		7	ns	2

Notes:

1. WE# must not remain LOW longer than 4 μ s (t_{CEM}) while the device is selected (CE# LOW).
2. Low-Z to High-Z timings are tested with the circuit shown in Figure 16.
The High-Z timings measure a 100mV transition from either VOH or VOL toward VDDQ/2.

Table18 . Burst WRITE Cycle Timing Requirements

Symbol	Parameter	-7013		-7010		-7008		Unit	Note
		Min	Max	Min	Max	Min	Max		
t_{AS}	Address and ADV# LOW Setup Time	0		0		0		ns	1
t_{CBPH}	CE# High between Subsequent Burst or Mixed-Mode Operations	5		5		6		ns	2
t_{CEM}	Maximum CE# Pulse width		4		4		4	us	2
t_{CLK}	CLK Period	7.5		9.62		12.5		ns	
t_{CSP}	CE# Setup Time to Active CLK Edge	2.5		3		4		ns	
t_{HD}	Hold Time from Active CLK Edge	2		2		2		ns	
t_{KH}/t_{KL}	CLK HIGH or LOW Time	3		3		4		ns	
t_{KW}	CLK to WAIT Valid		5.5		7		9	ns	3
t_{SP}	Setup time to Active CLK Edge	2		3		3		ns	
t_T	CLK Rise or Fall Time		1.2		1.6		1.8	ns	
t_{WZ}	CE# high to WAIT High-Z		7		7		7	ns	4

Notes:

1. t_{AS} required if $t_{CSP} > 20ns$.
2. A refresh opportunity must be provided every t_{CEM} by taking CE# HIGH.
3. t_{KW} value for -7013 is for variable LC = 4 and fixed LC = 8 only. For other LC settings, this parameter will be 7ns for -7013 devices.
4. Low-Z to High-Z timings are tested with the circuit shown in Figure 16.
The High-Z timings measure a 100mV transition from either VOH or VOL toward VDDQ/2.

Table19 . Initialization and DPD Timing Requirements

Symbol	Parameter	-70		Unit	Notes
		Min	Max		
t_{DPD}	Time from DPD entry to DPD exit	150		us	
t_{DPDX}	CE# LOW time to exit DPD	70		ns	
t_{PU}	Initialization Period (required before normal operations)		150	us	

Timing Diagrams

Figure 17: Power-Up Initialization Timing

Figure 18: DPD Entry and Exit Timing Parameters

Figure 19: Asynchronous READ

Figure 20: CLK Timings for Burst Operations

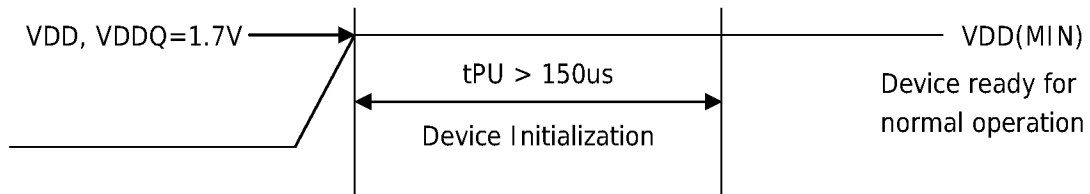
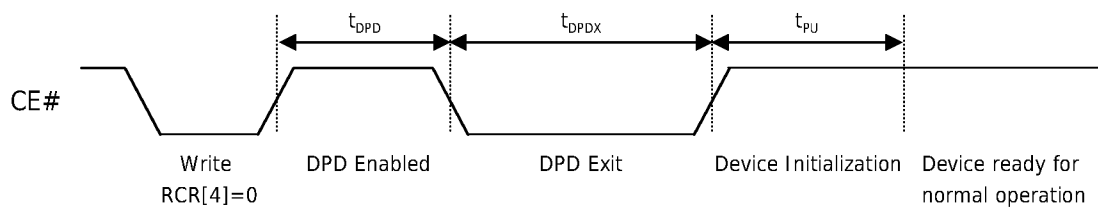
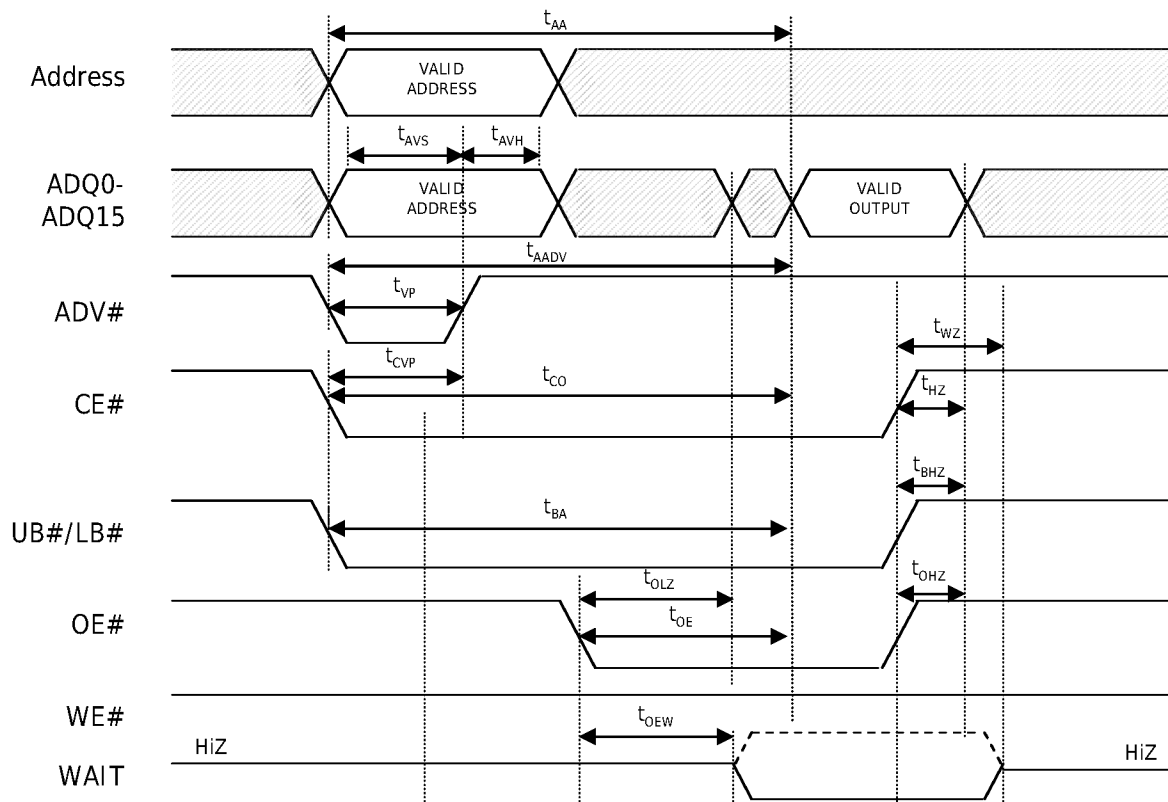
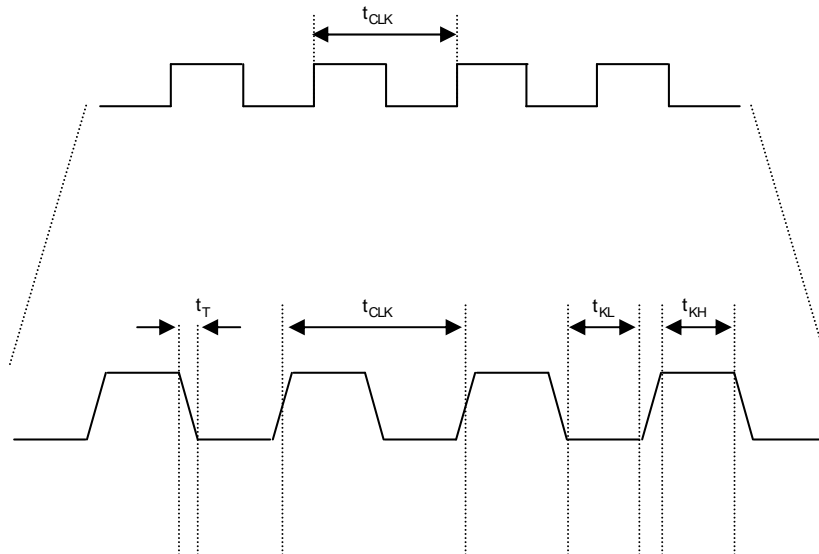
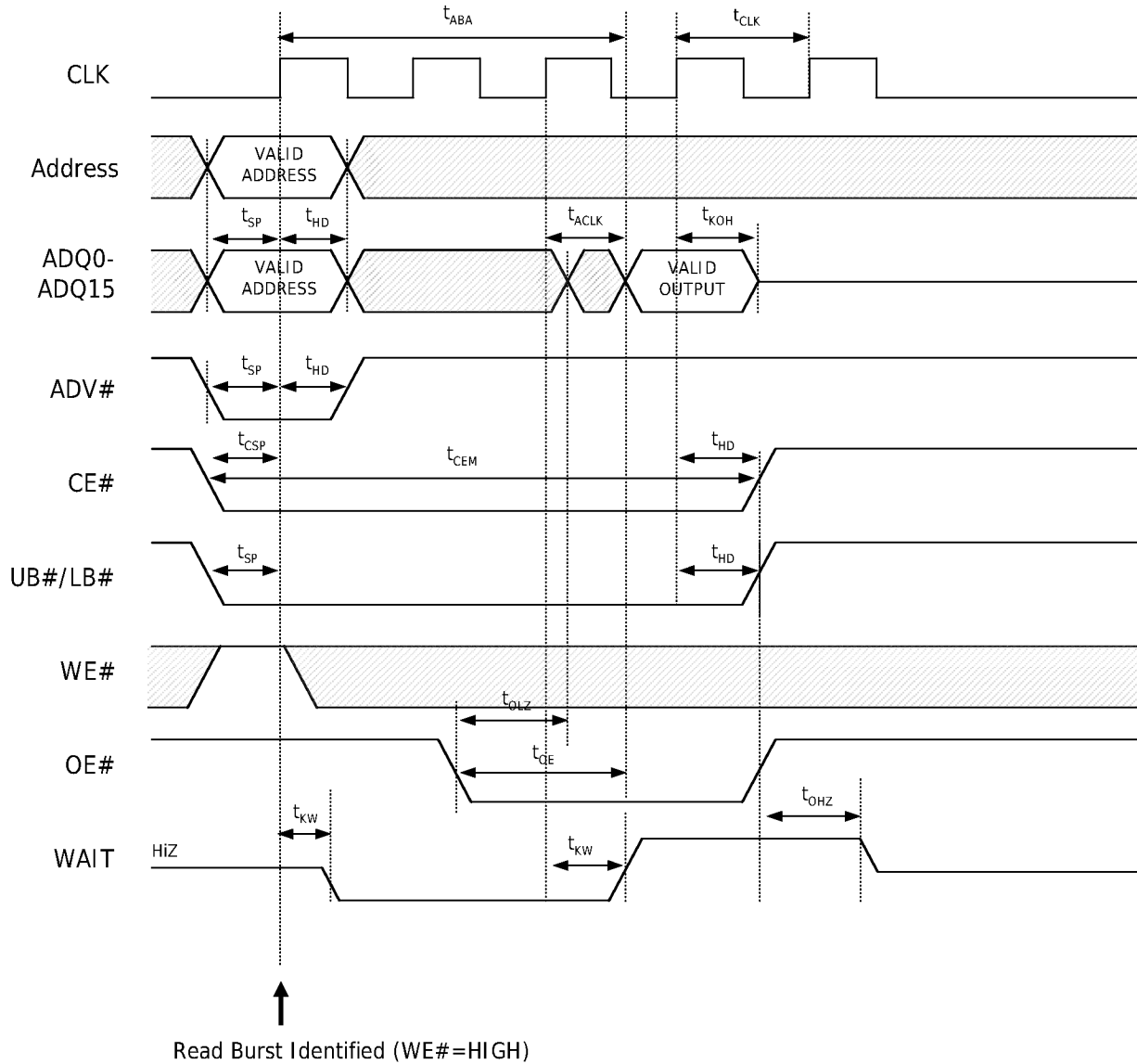

Notes :

1. For Burst timing diagrams, non-default BCR settings are shown

Figure 21: Single Access Burst READ Operation - Variable Latency without refresh collision

Notes:

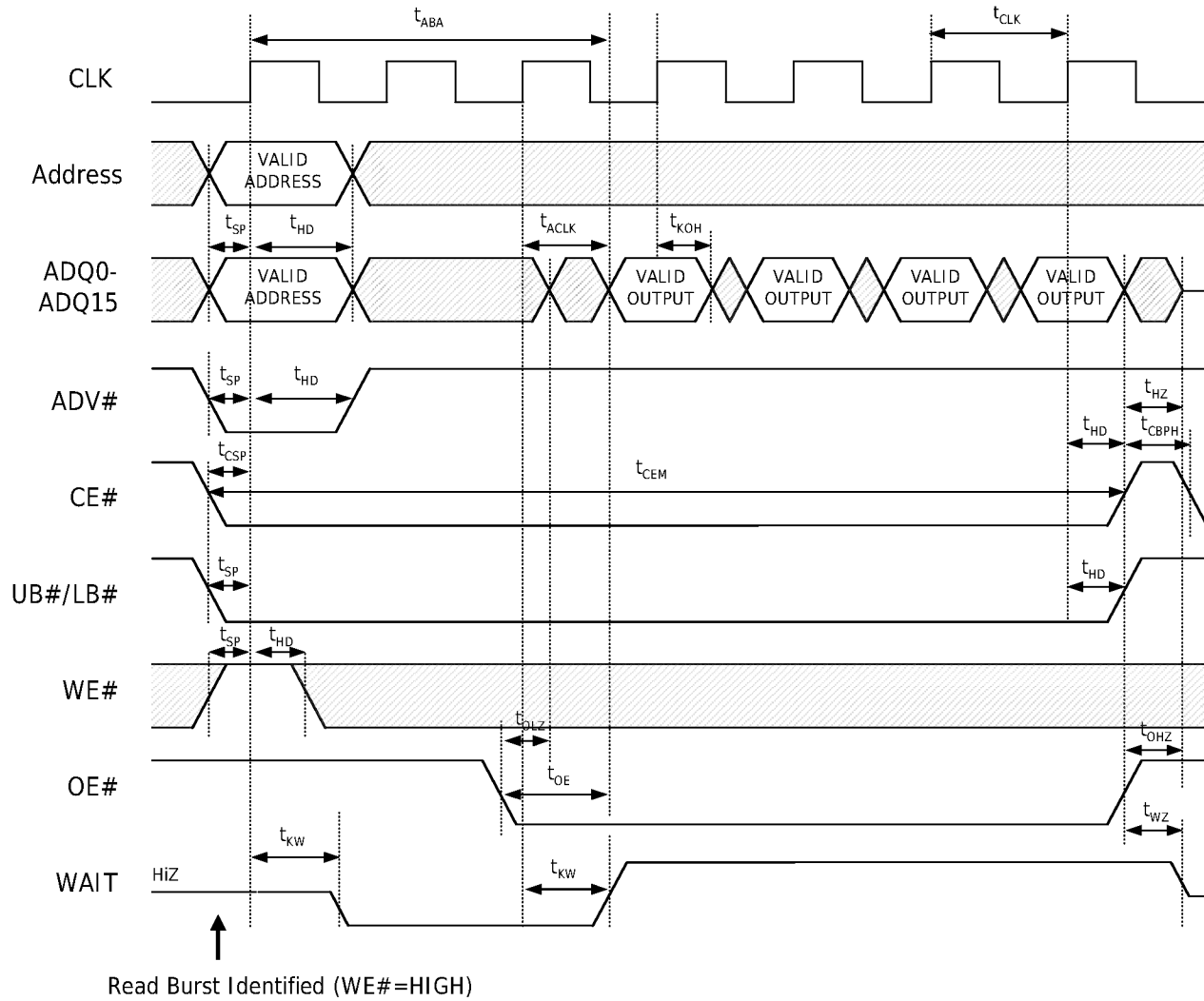
1. Non-default variable latency BCR settings for single-access burst READ operation: Latency code two (three clocks); WAIT active LOW; WAIT asserted during delay.

Figure 22: Four-Word Burst READ Operation - Variable Latency without refresh collision

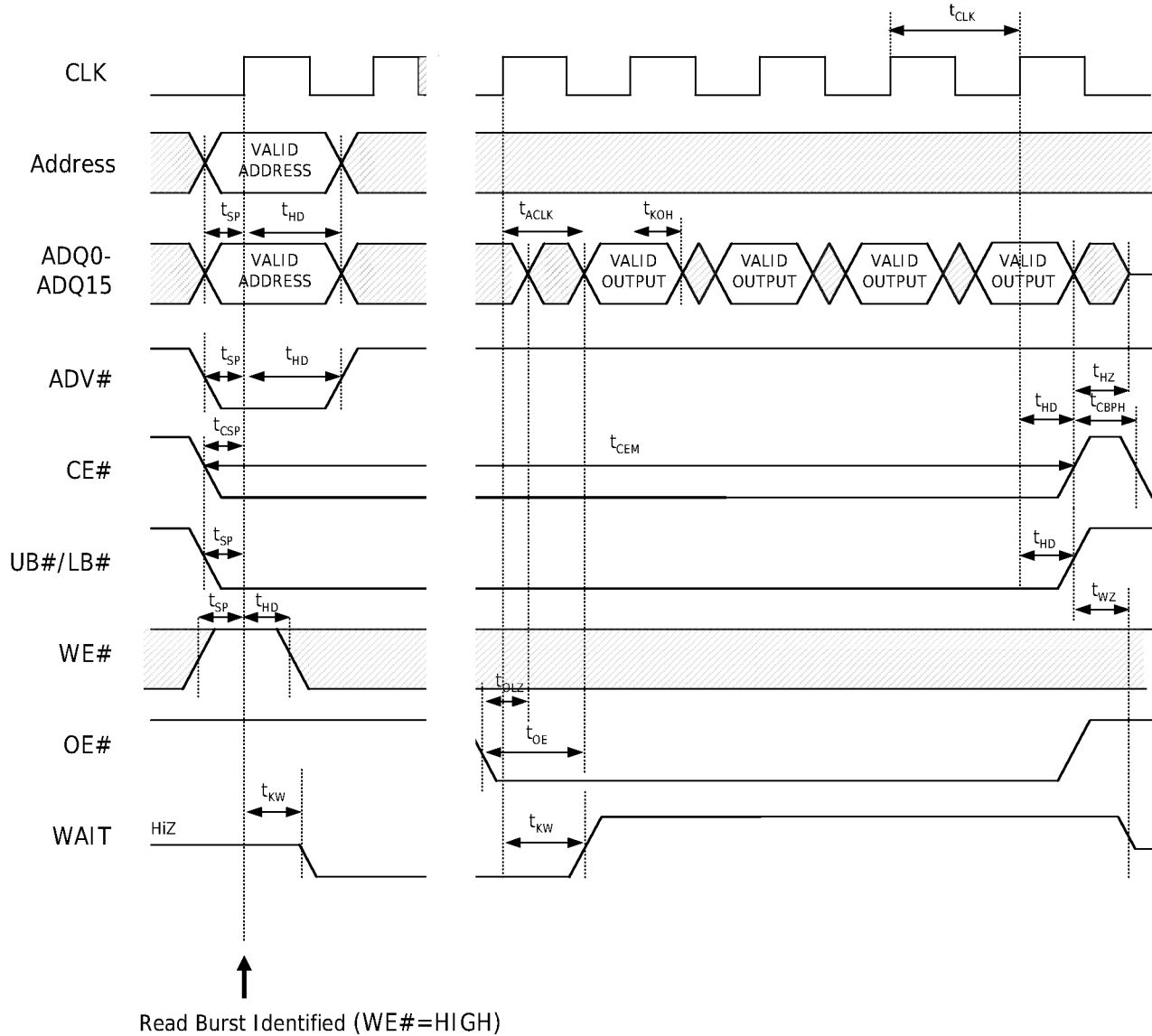
Notes:

1. Non-default variable latency BCR settings for 4-word burst READ operation: Latency code two (three clocks); WAIT active LOW; WAIT asserted during delay.

Figure 23: Four-Word Burst READ Operation - Variable Latency with refresh collision

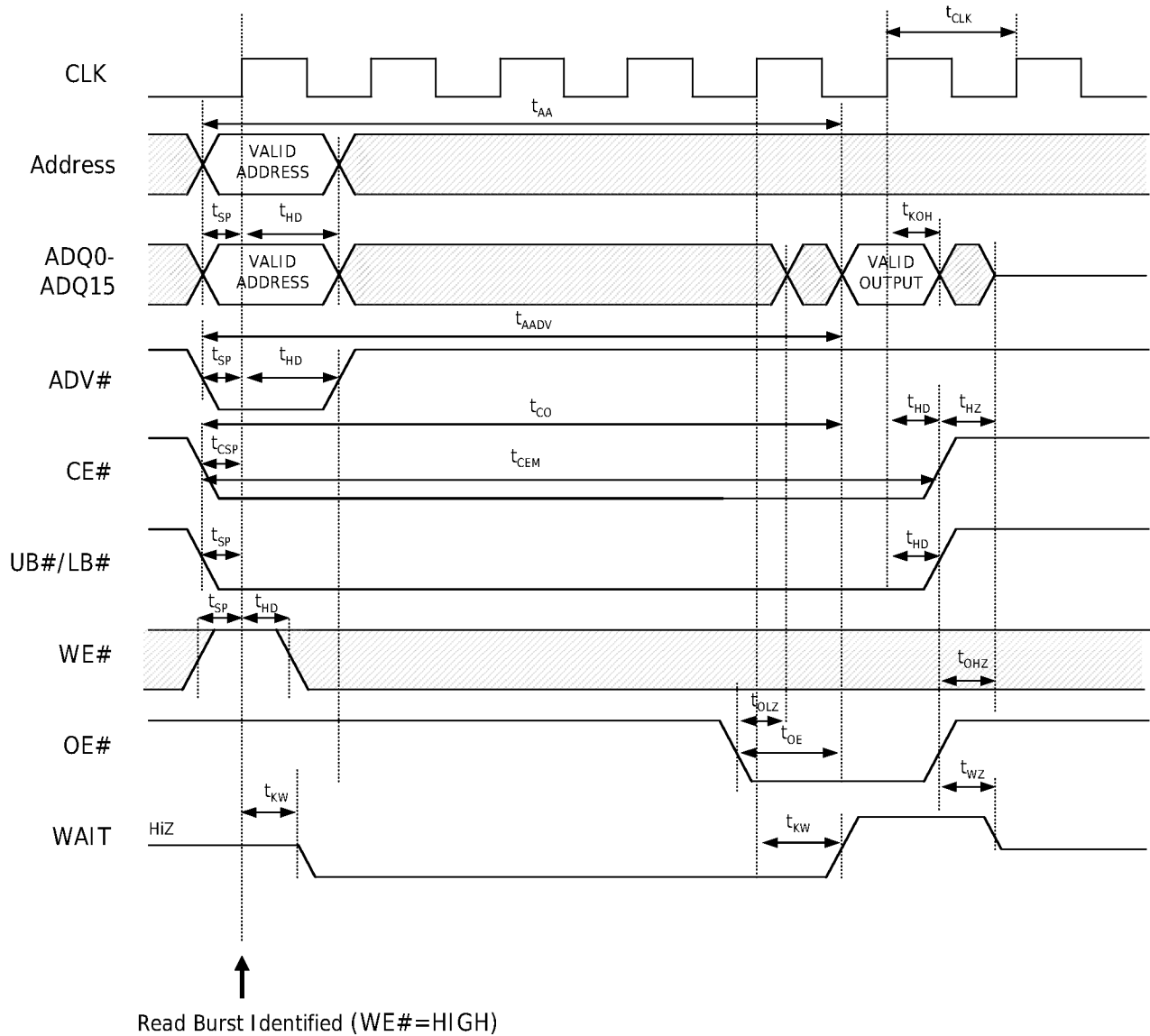
Notes:

1. Non-default variable latency BCR settings for 4-word burst READ operation: Latency code two (three clocks); WAIT active LOW; WAIT asserted during delay.
2. If refresh collision happened, WAIT will be asserted between the latency count number of clock cycles and 2x the latency count

Figure 24: Single Access Burst READ Operation - Fixed Latency

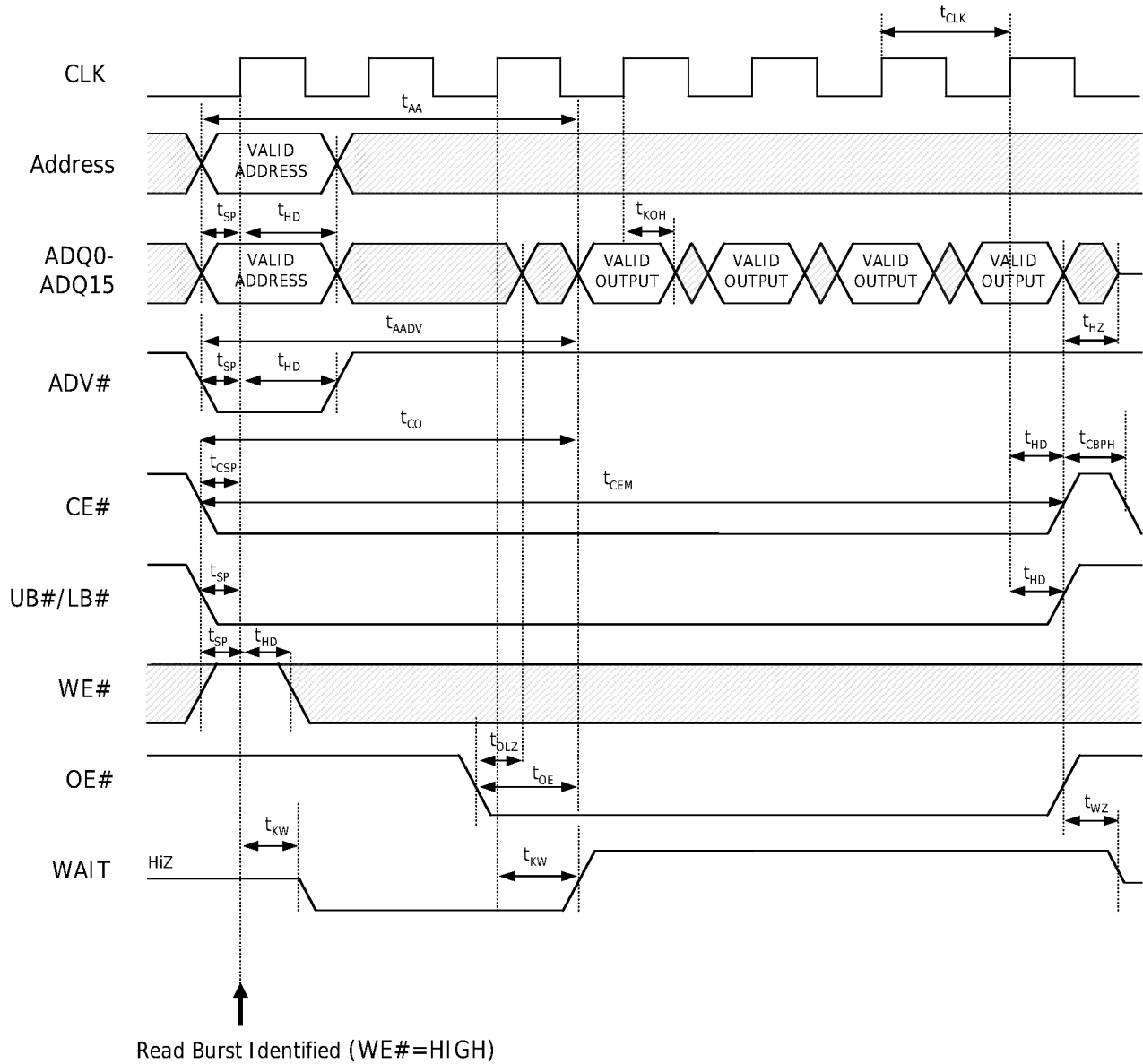
Notes:

1. Non-default fixed latency BCR settings for single-access burst READ operation: Fixed Latency; Latency code four (five clocks); WAIT active LOW; WAIT asserted during delay.

Figure 25: Four-Word Burst READ Operation - Fixed Latency

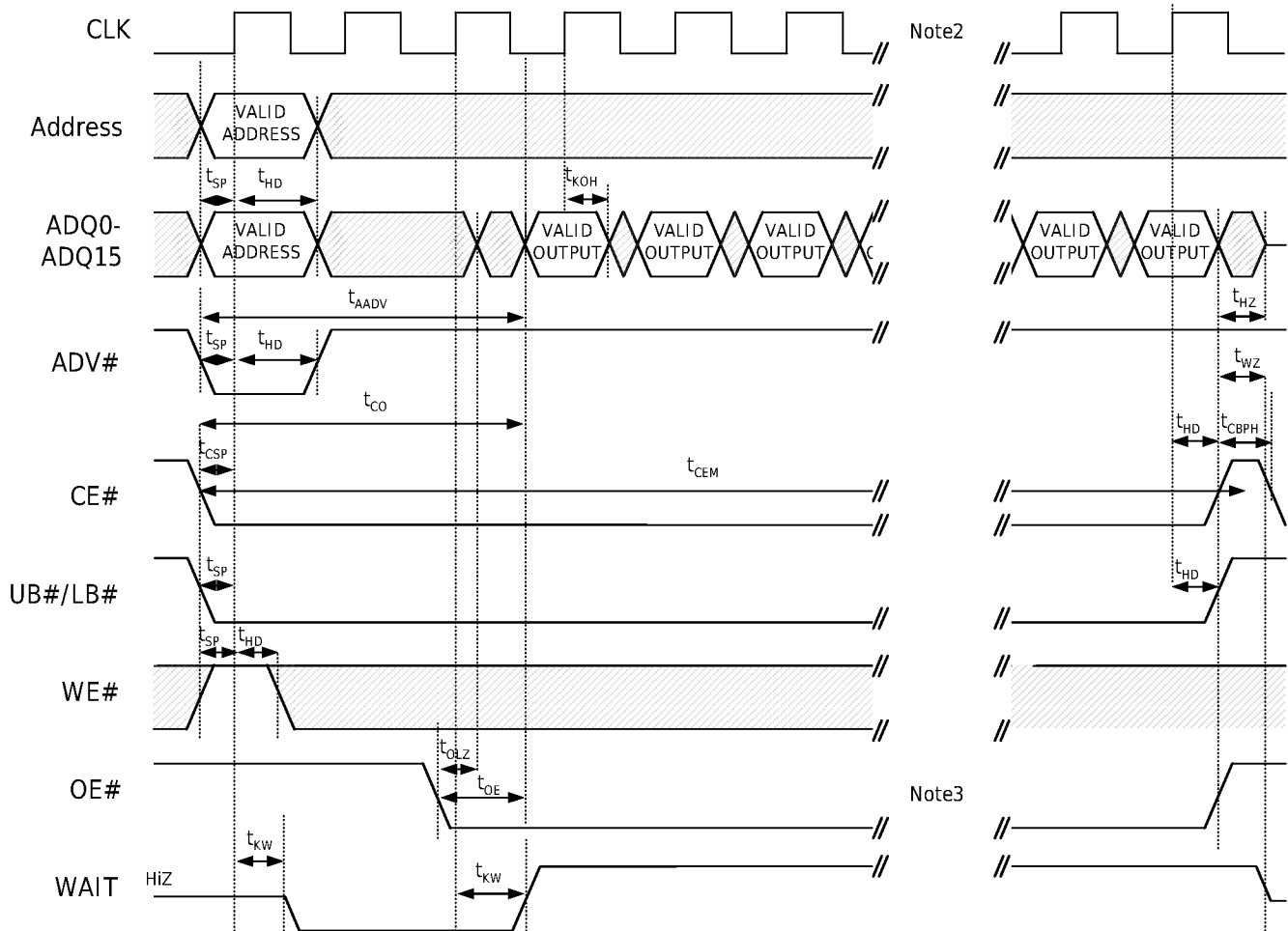
Notes:

1. Non-default fixed latency BCR settings for 4-word burst READ operation: Fixed latency; latency code two (three clocks); WAIT active LOW; WAIT asserted during delay.

Figure 26: READ Burst Suspend

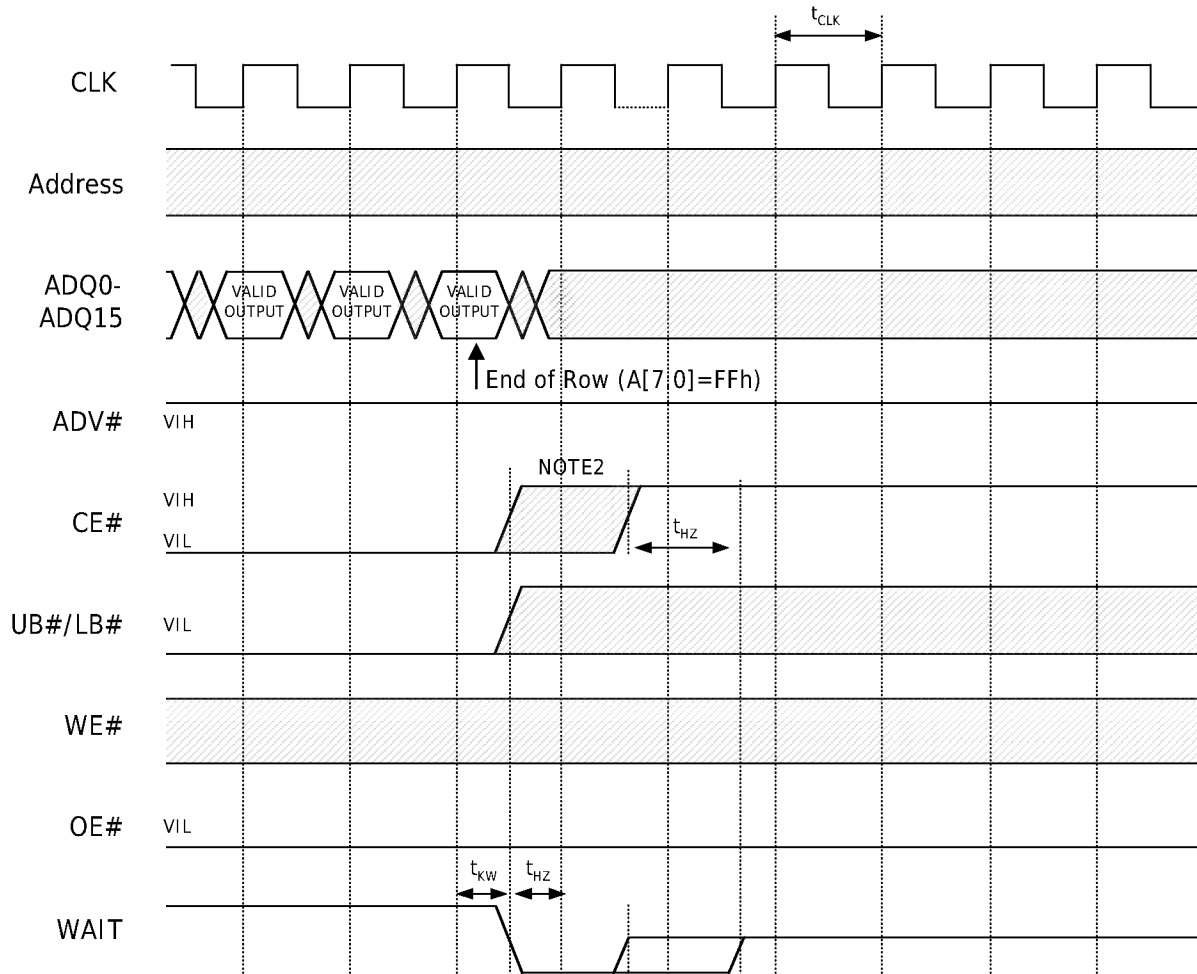
Notes:

1. Non-default BCR settings for READ burst suspend: Fixed or variable latency; latency code two (three clocks); WAIT active LOW; WAIT asserted during delay.
2. CLK can be stopped LOW or HIGH, but must be static, with no LOW-to-HIGH transitions during burst suspend.
3. OE# can stay LOW during BURST SUSPEND. If OE# is LOW, ADQ[15:0] will continue to output valid data.

Figure 27: Burst READ at End of Row (Wrap Off)

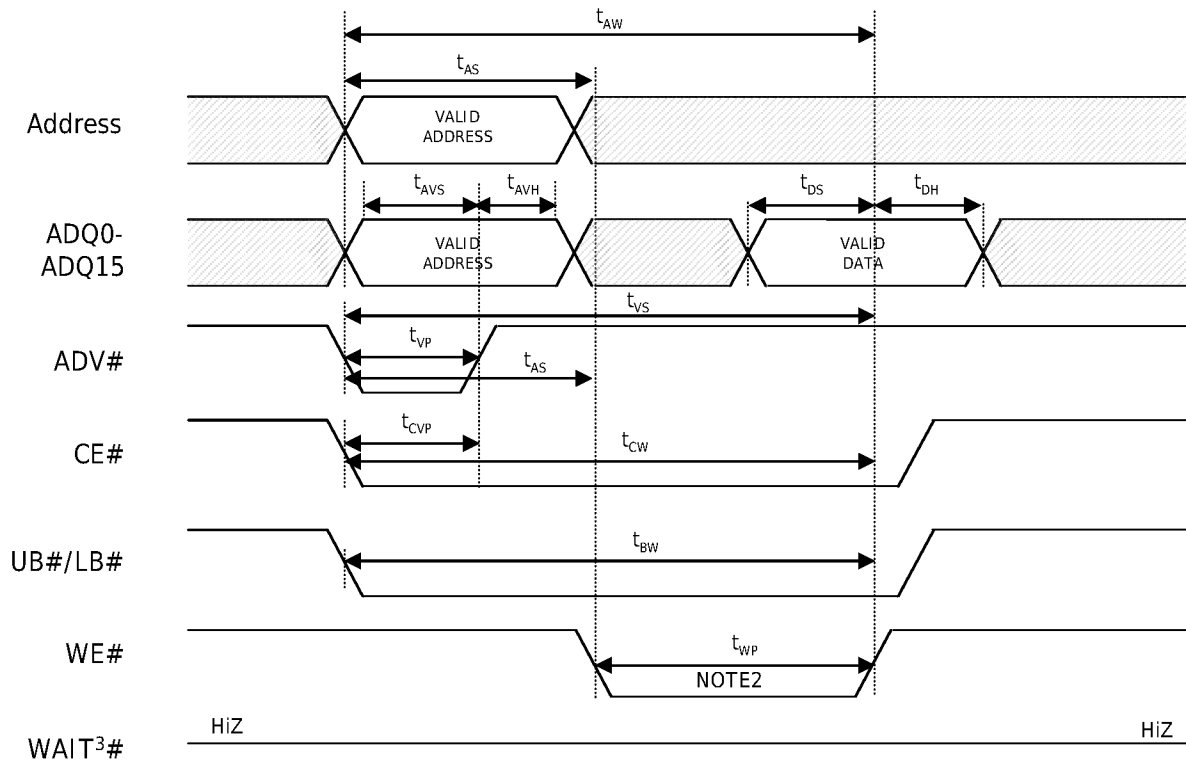
Notes:

1. Non-default BCR settings for burst READ at end of row: fixed or variable latency; WAIT active LOW; WAIT asserted during delay.
2. For burst READs, CE# must go HIGH before the third CLK after the WAIT period begins (before the third CLK after WAIT asserts with BCR[8] = 0, or before the fourth CLK after WAIT asserts with BCR[8] = 1).

Figure 28: Asynchronous WRITE

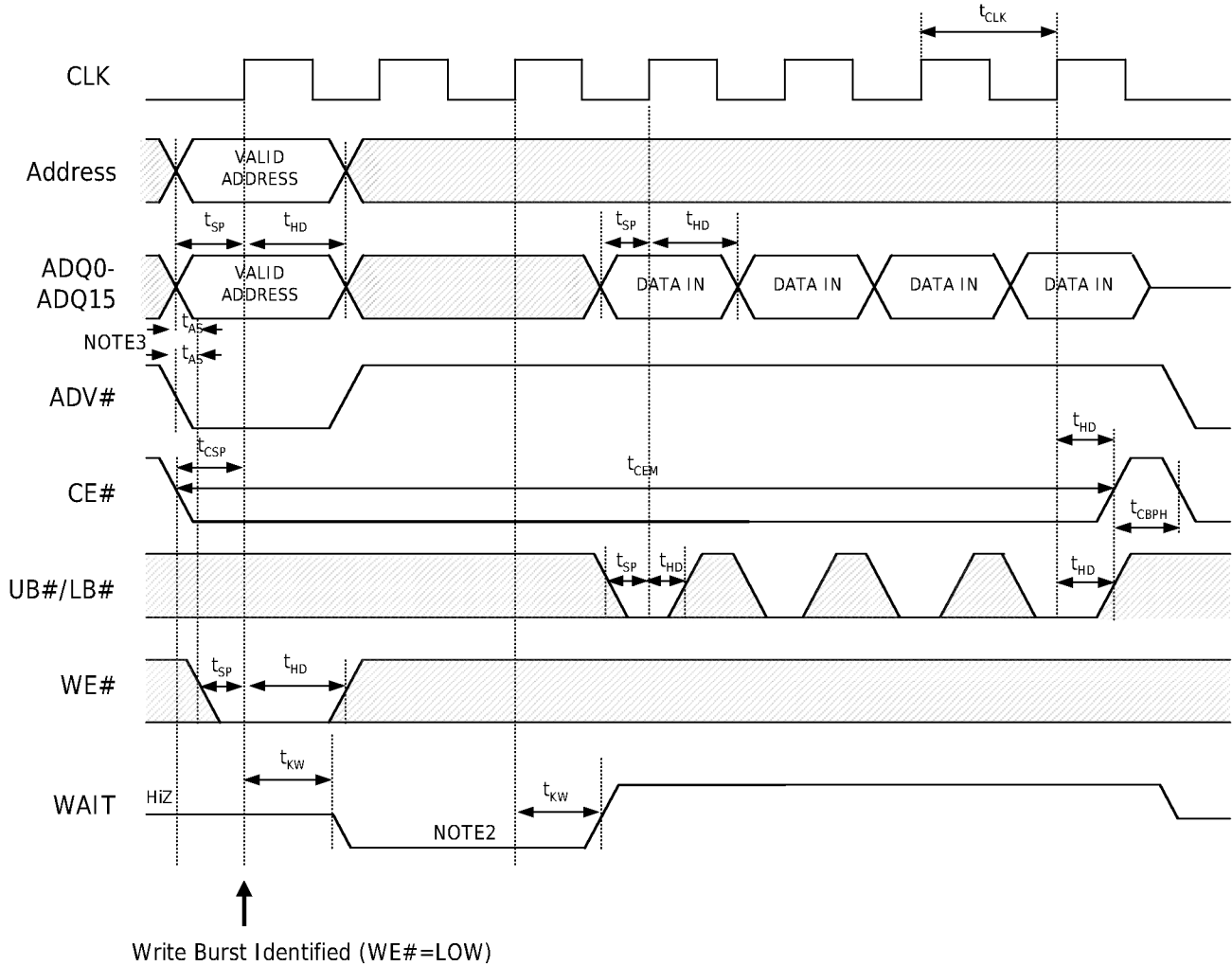
Notes:

1. The end of the WRITE cycle is controlled by CE#, UB#, LB#, or WE#, whichever de-asserts first.
2. WE# must not remain LOW longer than 4 μ s (t_{CEM}) while the device is selected (CE# LOW).
3. During asynchronous WRITE cycles, WAIT will be High-Z while WE# is LOW or OE# is HIGH.

Figure 29: Four-Word Burst WRITE Operation - Variable Latency

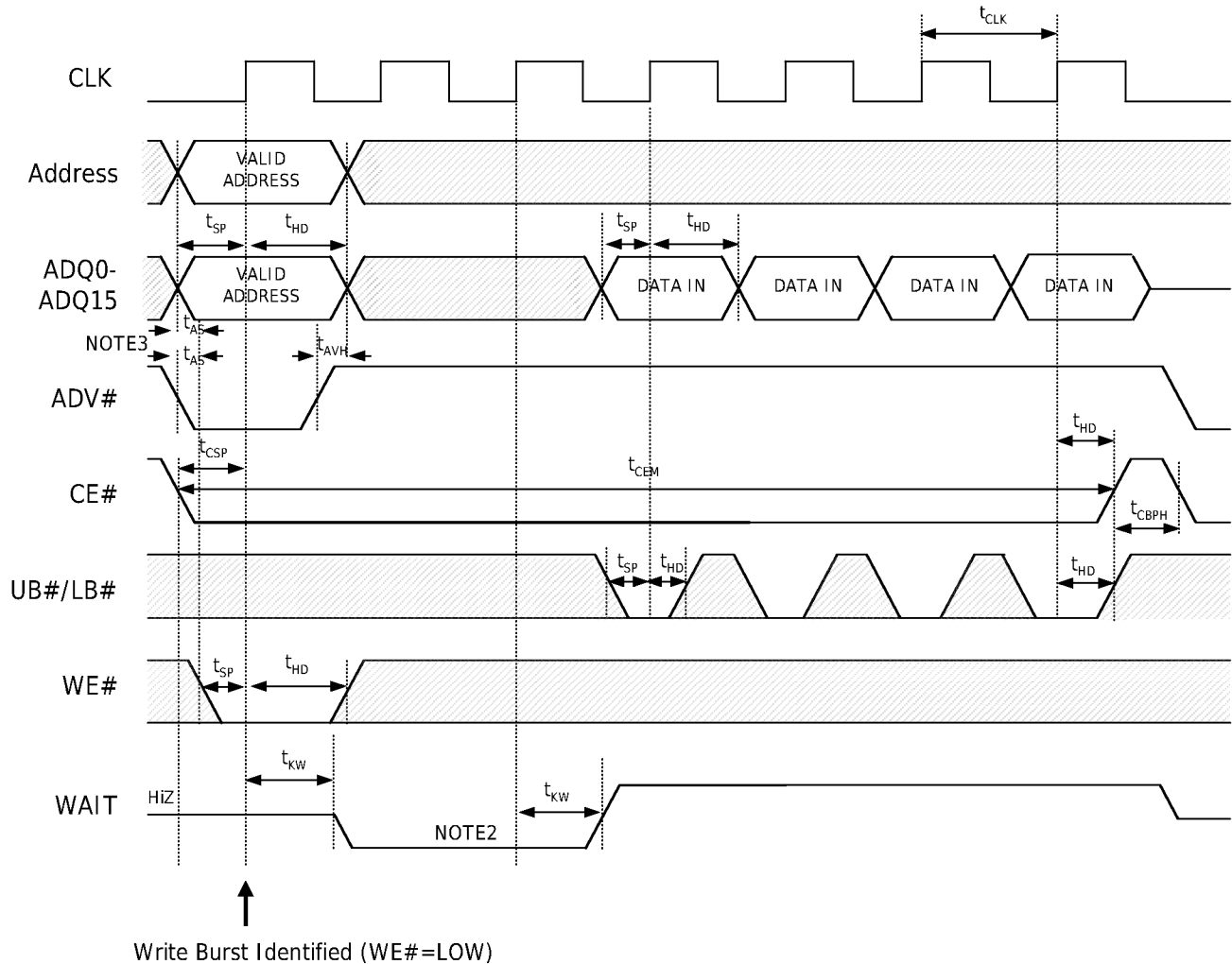
Notes:

1. Non-default BCR settings for burst WRITE operation, with fixed-length burst of 4, burst wrap enabled: Variable latency; latency code two (three clocks); WAIT active LOW; WAIT asserted during delay.
2. WAIT asserts for LC cycles for both fixed and variable latency. LC = latency code (BCR[13:11]).
3. tAS required if tCSP > 20ns.

Figure 30: Four-Word Burst WRITE Operation - Fixed Latency

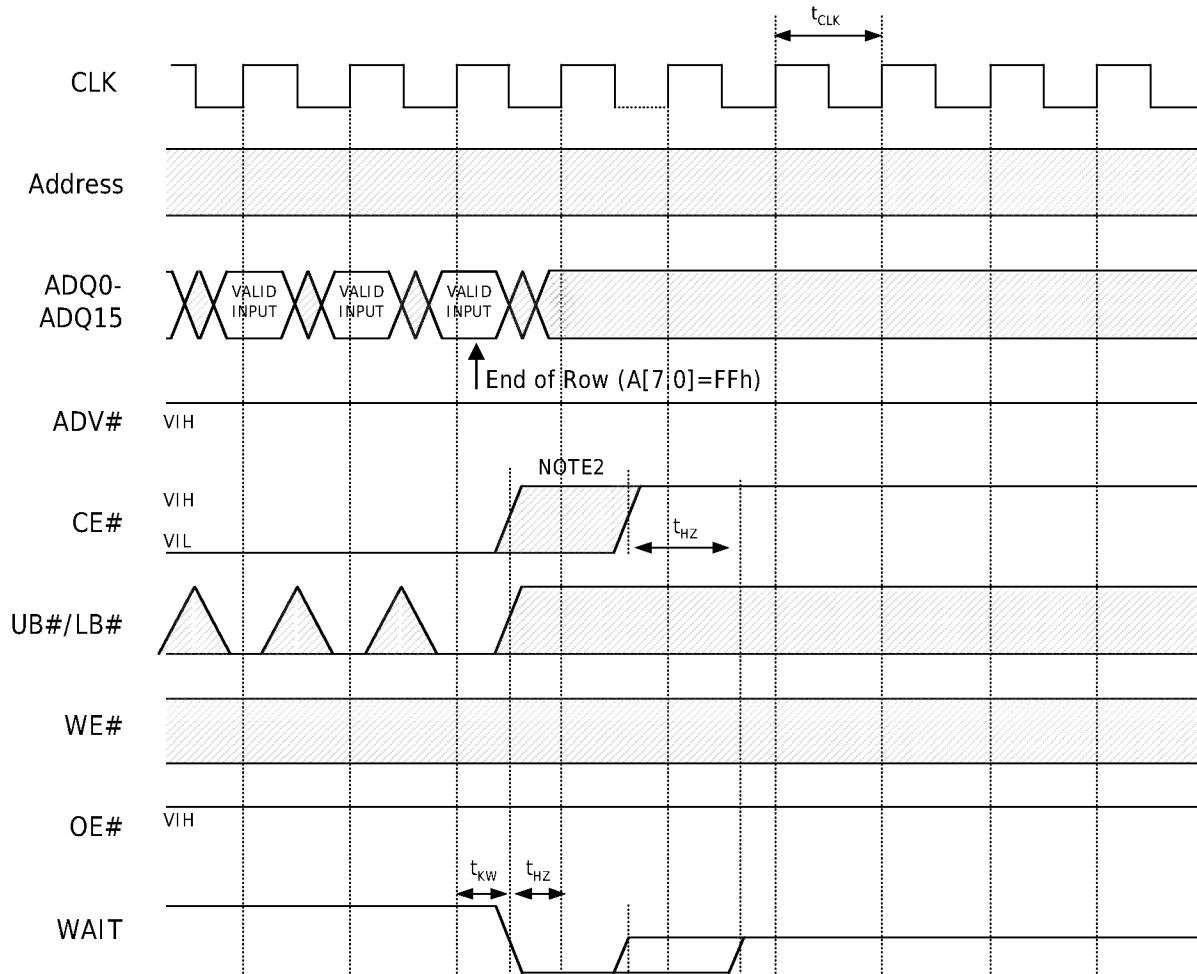
Notes:

1. Non-default BCR settings for burst WRITE operation, with fixed-length burst of 4, burst wrap enabled:
Fixed latency; latency code two (three clocks); WAIT active LOW; WAIT asserted during delay.
2. WAIT asserts for LC cycles for both fixed and variable latency. LC = latency code (BCR[13:11]).
3. t_{AS} required if $t_{CSP} > 20ns$.

Figure 31: Continuous Burst WRITE at End-of-Row (Wrap Off)

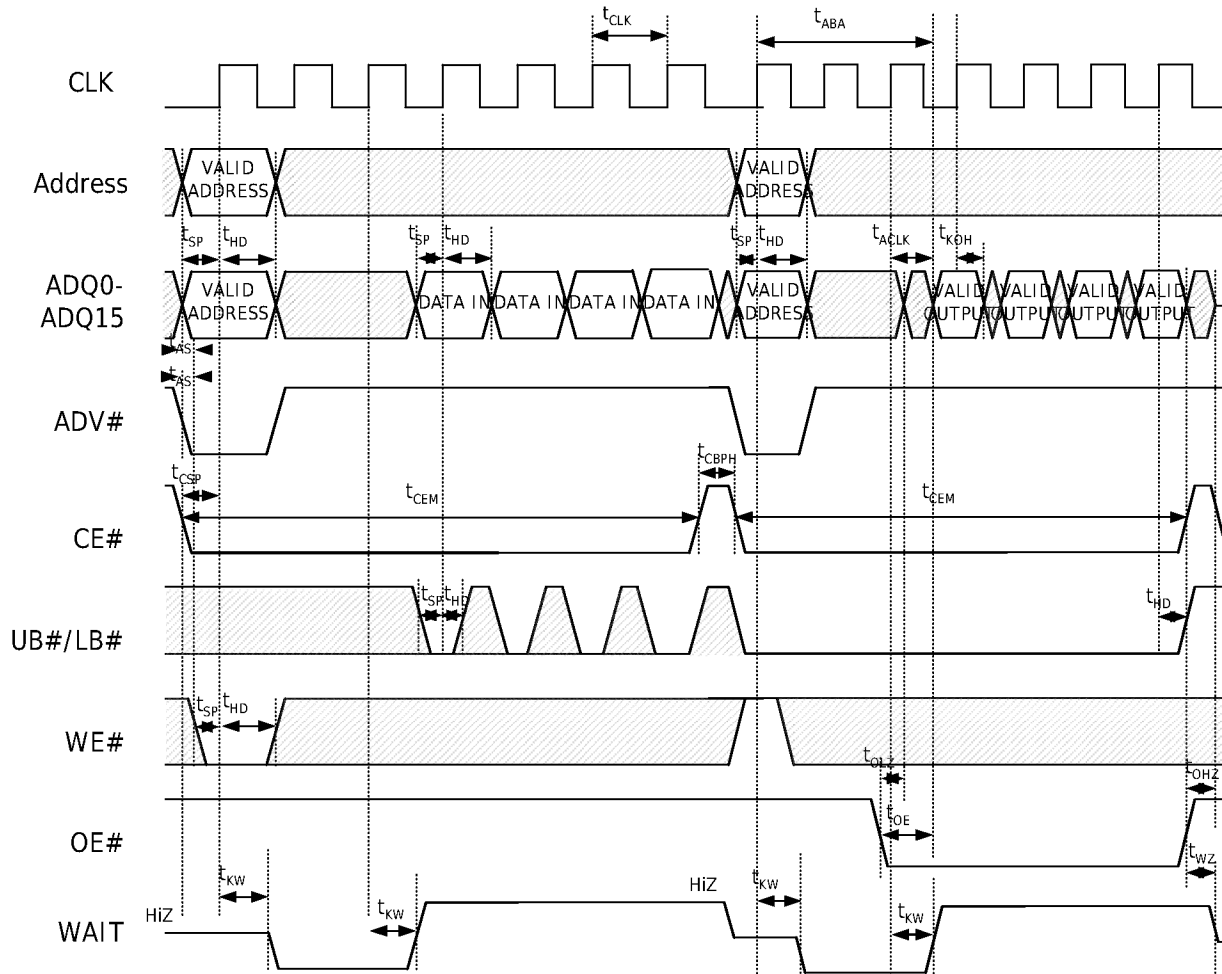
Notes:

1. Non-default BCR settings for burst WRITE at end of row: fixed or variable latency; WAIT active LOW; WAIT asserted during delay.
2. For burst WRITES, CE# must go HIGH before the third CLK after the WAIT period begins (before the third CLK after WAIT asserts with BCR[8] = 0, or before the fourth CLK after WAIT asserts with BCR[8] = 1).

Figure 32: Burst WRITE followed by Burst READ

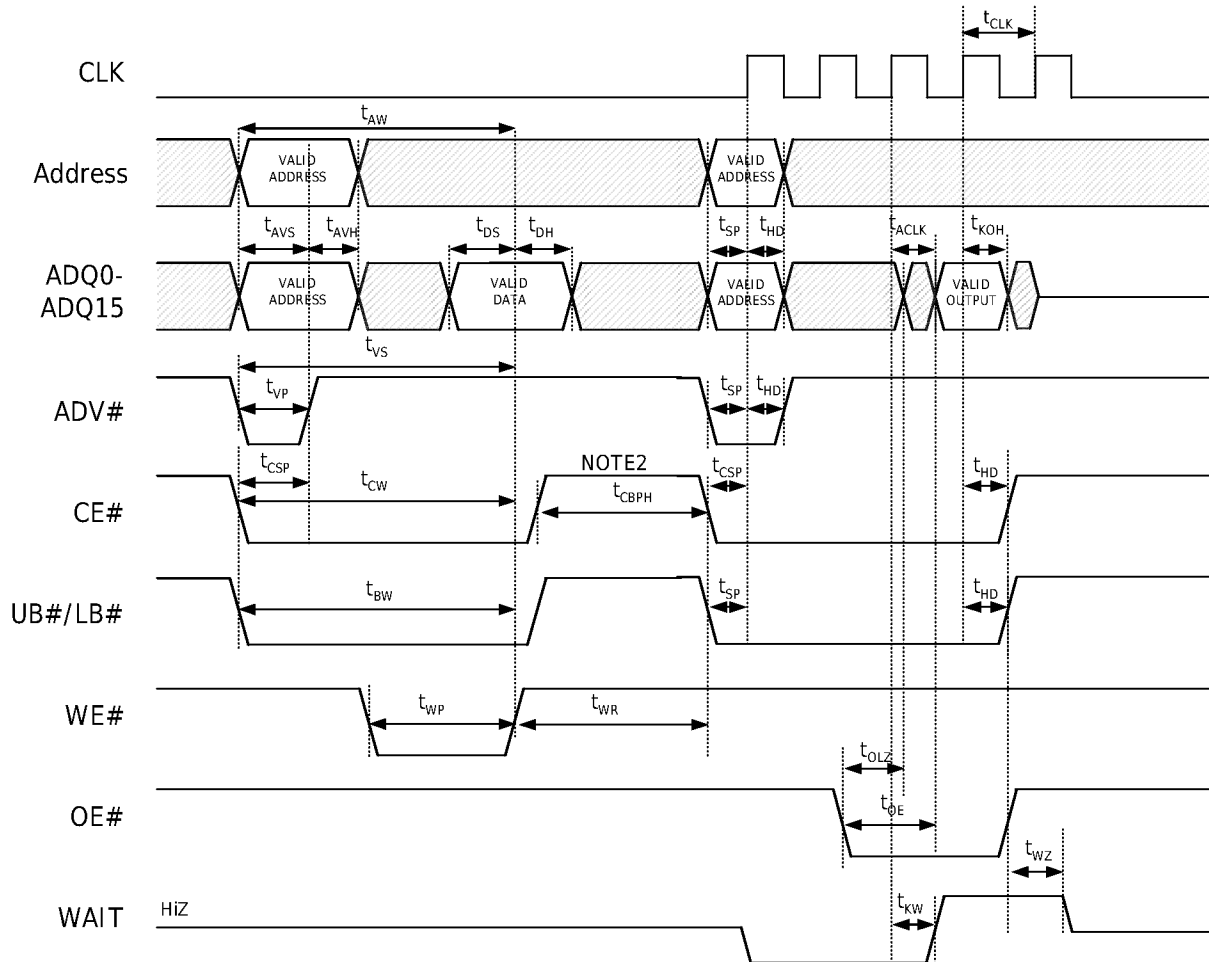
Notes:

1. Non-default BCR settings for burst WRITE followed by burst READ; latency code two (three clocks); WAIT active LOW; WAIT asserted during delay.
2. A refresh opportunity must be provided every t_{CEM} by taking CE# HIGH.

Figure 33: Asynchronous WRITE followed by Burst READ

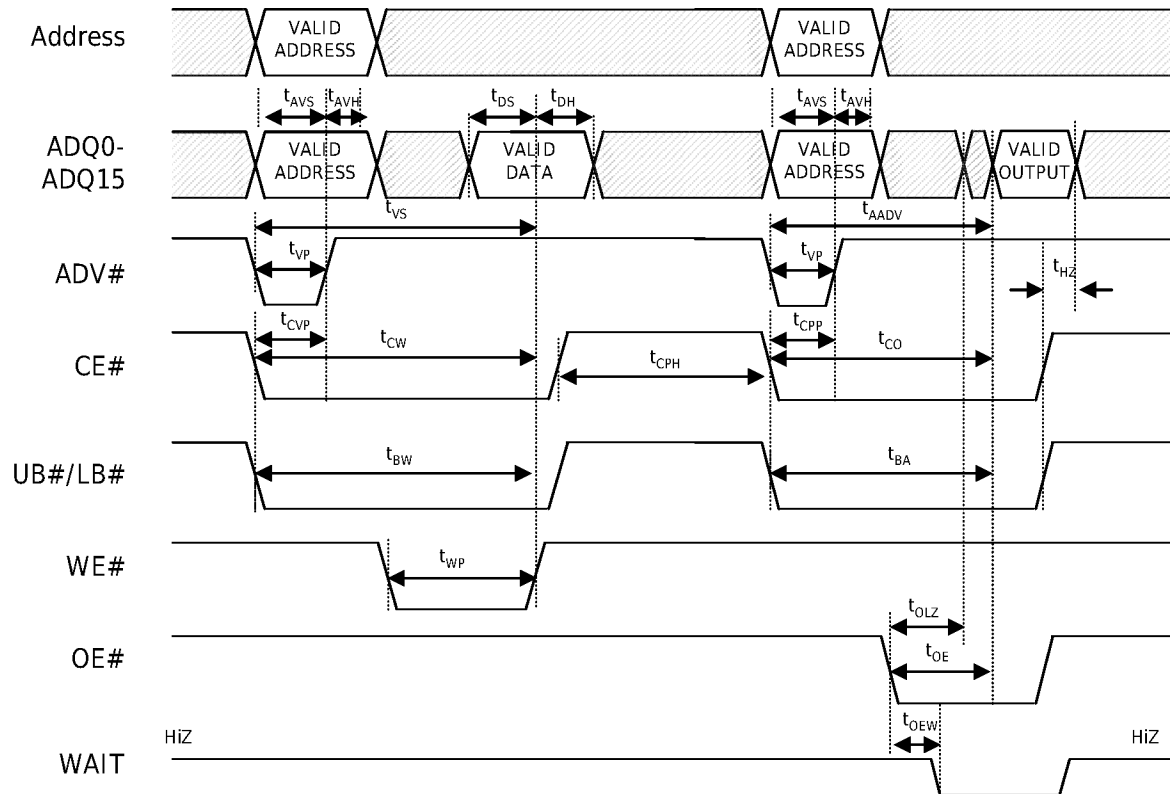
Notes:

1. Non-default BCR settings for asynchronous WRITE followed by burst READ: Fixed or variable latency; latency code two (three clocks); WAIT active LOW; WAIT asserted during delay.
2. When transitioning between asynchronous WRITE and variable-latency burst READ operations, CE# must go HIGH. CE# can stay LOW when transitioning to fixed-latency burst READS. A refresh opportunity must be provided every tCEM by taking CE# HIGH.

Figure 34: Asynchronous WRITE followed by Asynchronous READ

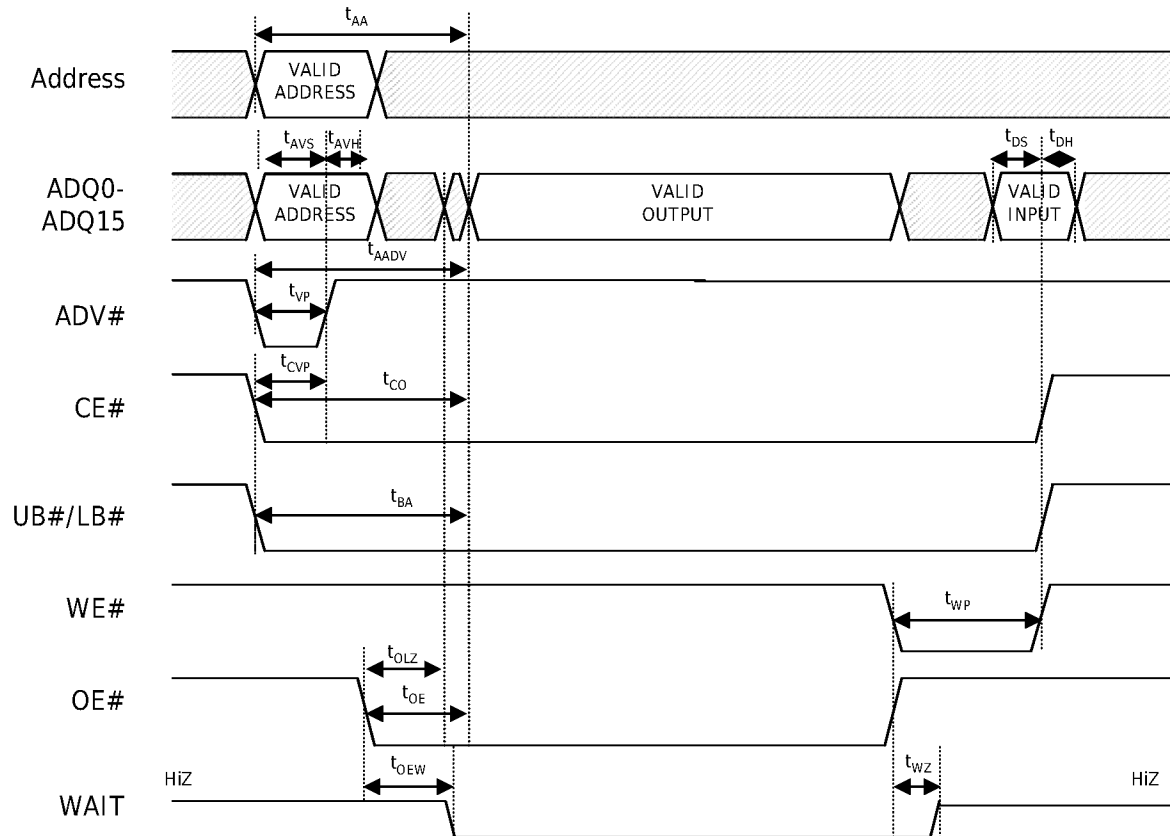
Notes:

1. CE# can stay LOW when transitioning between asynchronous operations. If CE# goes HIGH, it must remain HIGH for at least t_{CPH} to schedule the appropriate internal refresh operation. Otherwise, t_{CPH} is only required after CE#-controlled WRITES.

Figure 35: Asynchronous READ followed by WRITE at the Same Address

Notes:

1. The end of the WRITE cycle is controlled by CE#, UB#, LB#, or WE#, whichever de-asserts first.
2. WE# must not remain LOW longer than $4\mu\text{s}$ (t_{CEM}) while the device is selected (CE# LOW).

Ordering Information – VDD = 1.8V

Industrial Temperature Range: (-40°C to +85°C)

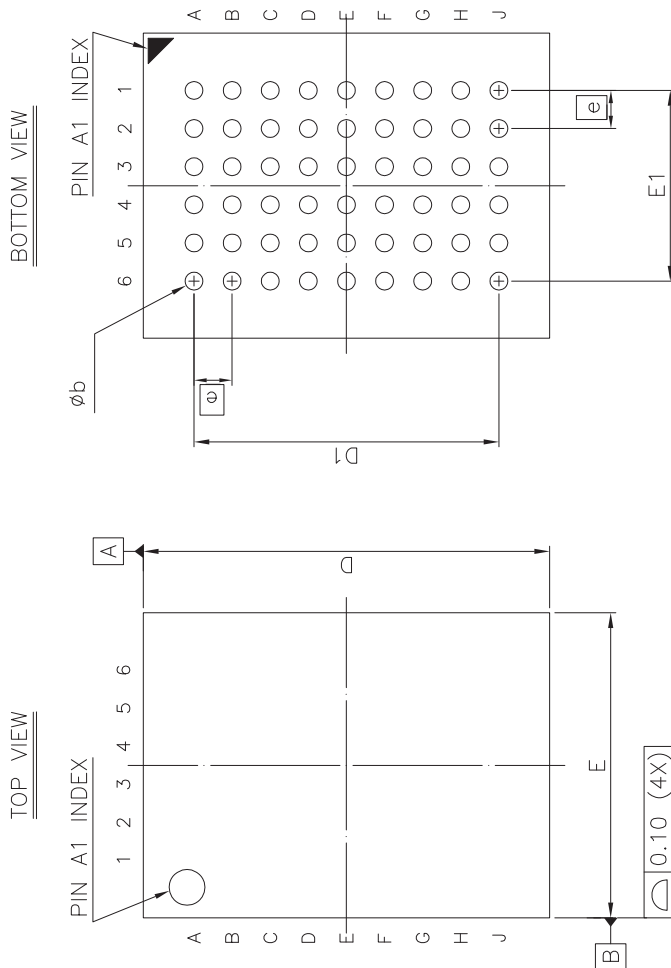
Config.	Speed (ns)	Frequency (MHz)	Order Part No.	Package
4Mx16	70	133	IS66WVD4M16ALL-7013BLI	54-ball VFBGA
		104	IS66WVD4M16ALL-7010BLI	54-ball VFBGA
		80	IS66WVD4M16ALL-7008BLI	54-ball VFBGA



SYM.	DIMENSION (mm)			DIMENSION (inch)		
	MIN.	NOM.	MAX.	MIN.	NOM.	MAX.
A	—	—	1.00	—	—	0.039
A1	0.20	0.25	0.30	0.008	0.010	0.012
b	0.30	0.35	0.40	0.012	0.014	0.016
D	7.95	8.00	8.05	0.313	0.315	0.317
D1	6.00 BSC			0.236 BSC		
E	5.95	6.00	6.05	0.234	0.236	0.238
E1	3.75 BSC			0.148 BSC		
[e]	0.75 BSC			0.030 BSC		

NOTE:
1. CONTROLLING DIMENSION : MM
2. REFERENCE DOCUMENT : JEDEC MO-207.

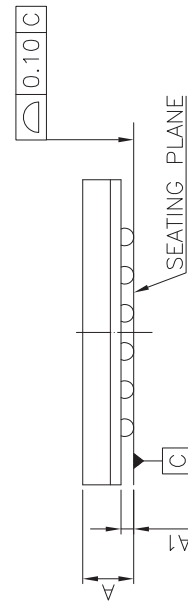

SIDE VIEW



TITLE

54L 6x8mm VF-BGA
Package Outline

REV.

A

DATE

09/07/2009