

1.5 AMP POSITIVE ADJUSTABLE VOLTAGE REGULATOR APPROVED TO DESC DRAWING 7703401



**Three Terminal, Precision Adjustable
 Positive Voltage Regulator In Hermetic
 Style Packages (LM117)**

FEATURES

- Similar To Industry Standard LM117
- Approved To DESC Standardized Military Drawing Number 7703401
- Built In Thermal Overload Protection
- Short Circuit Current Limiting
- Available In Six Package Styles

DESCRIPTION

These three terminal positive regulators are supplied in hermetically sealed packages. All protective features are designed into the circuit, including thermal shutdown, current-limiting, and safe-area control. With heat sinking, these devices can deliver up to 1.5 amps of output current. The LCC-20 device is limited to .5 amps. The unit also features output voltages that can be fixed from 1.2 volts to 37 volts using external resistors.

ABSOLUTE MAXIMUM RATINGS $T_c @ 25^\circ\text{C}$

Power Dissipation	
Case 2	1.1 W
Case-All Others.	20 W
Input - Output Voltage Differential	40 V
Operating Junction Temperature Range	- 55°C to + 150°C
Storage Temperature Range	- 65°C to + 150°C
Lead Temperature (Soldering 10 seconds)	300°C
Thermal Resistance, Junction to Case:	
Case 2, LCC-20	17°C/W
Case U & M, TO-257 (Isol) and SMD-3	4.2°C/W
Case T&N, TO-257 (Non-Isol) and SMD-1	3.5°C/W
Case Y, TO-3.	3.0°C/W
Maximum Output Current:	
Case 25 A
Case-All Others.	1.5 A
<u>Recommended Operating Conditions:</u>	
Output Voltage Range	1.2 to 37 VDC
Ambient Operating Temperature Range (T_A).	- 55°C to + 125°C
Input Voltage Range	4.25 to 41.25 VDC

3.5



OM1320NTM, OM1320STM, OM1320NKM, OM1320SMM, OM1320NMM, OM1320N2M

ELECTRICAL CHARACTERISTICS -55°C T_A 125°C, $I_L = 8mA$ (unless otherwise specified)
OM1320NTM, OM1320STM, OM1320NKM, OM1320SMM, OM1320NMM

Parameter	Symbol	Test Conditions	Min.	Max.	Unit
Reference Voltage	V_{REF}	$V_{DIFF} = 3.0V, T_A = 25^\circ C$ $V_{DIFF} = 3.3V$ • $V_{DIFF} = 40V$ •	1.20 1.20 1.20	1.30 1.30 1.30	V
Line Regulation (Note 1)	R_{LINE}	3.0V V_{DIFF} 40V, $V_{out} = V_{ref}, T_A = 25^\circ C$ 3.3V V_{DIFF} 40V, $V_{out} = V_{ref}$ •	-9 -23	9 23	mV
Load Regulation (Note 1)	R_{LOAD}	$V_{DIFF} = 3.0V, 10mA$ I_L 1.5A, $T_A = 25^\circ C$ $V_{DIFF} = 3.3V, 10mA$ I_L 1.5A • $V_{DIFF} = 40V, 10mA$ I_L 300mA, $T_A = 25^\circ C$ $V_{DIFF} = 40V, 10mA$ I_L 195mA •	-15 -15 -15	15 15 15	mV
Thermal Regulation	V_{RTH}	$V_{in} = 14.6V, I_L = 1.5A$ $P_d = 20$ Watts, $t = 20$ ms, $T_A = 25^\circ C$	-16	16	mV
Ripple Rejection (Note 2)	R_N	$f = 120$ Hz, $V_{out} = V_{ref}$ • $C_{Adj} = 10$ μF	66		dB
Adjustment Pin Current	I_{Adj}	$V_{DIFF} = 3.0V, T_A = 25^\circ C$ $V_{DIFF} = 3.3V$ • $V_{DIFF} = 40V$ •		100 100 100	μA
Adjustment Pin Current Change	I_{Adj}	$V_{DIFF} = 3.0V, 10mA$ I_L 1.5A, $T_A = 25^\circ C$ $V_{DIFF} = 3.3V, 10mA$ I_L 1.5A • $V_{DIFF} = 40V, 10mA$ I_L 300mA, $T_A = 25^\circ C$ • $V_{DIFF} = 40V, 10mA$ I_L 195mA • 3.0V V_{DIFF} 40V, $T_A = 25^\circ C$ 3.3V V_{DIFF} 40V •	-5 -5 -5 -5 -5	5 5 5 5 5	μA
Minimum Load Current	I_{Lmin}	$V_{DIFF} = 3.0V, V_{OUT} = 1.4V$ (forced) $V_{DIFF} = 3.3V, V_{OUT} = 1.4V$ (forced) • $V_{DIFF} = 40V, V_{OUT} = 1.4V$ (forced) •		5.0 5.0 5.0	mA
Current Limit (Note 2)	I_{CL}	$V_{DIFF} = 15V$ • $V_{DIFF} = 40V, T_A = 25^\circ C$	1.5 0.18	3.5 1.5	A

Notes:

1. Load and Line Regulation are specified at a constant junction temperature. Pulse testing with low duty cycle is used. Changes in output voltage due to heating effects must be taken into account separately.
2. If not tested, shall be guaranteed to the specified limits.
3. The • denotes the specifications which apply over the full operating temperature range.

3.5

PART NUMBER DESIGNATOR		
Standard Military Drawing Number	Omnirel Part Number	Omnirel Package Designation
7703401M 7703401U 7703401T 7703401Y 7703401N 77034012	OM1320SMM OM1320STM OM1320NTM OM1320 NKM OM1320NMM OM1320N2M	SMD-3 TO-257 (Isolated) TO-257 (non-Isolated) TO-3 SMD-1 LCC-20



OM1320NTM, OM1320STM, OM1320NKM, OM1320SMM, OM1320NMM, OM1320N2M

ELECTRICAL CHARACTERISTICS -55°C T_A 125°C, $I_L = 8\text{mA}$ (unless otherwise specified)

OM1320N2M

Parameter	Symbol	Test Conditions	Min.	Max.	Unit
Reference Voltage	V_{REF}	$V_{DIFF} = 3.0\text{V}$, $T_A = 25^\circ\text{C}$	1.20	1.30	V
		$V_{DIFF} = 3.3\text{V}$	• 1.20	1.30	
		$V_{DIFF} = 40\text{V}$	• 1.20	1.30	
Line Regulation (Note 1)	R_{LINE}	3.0V V_{DIFF} 40V , $V_{out} = V_{ref}$, $T_A = 25^\circ\text{C}$	-9	9	mV
		3.3V V_{DIFF} 40V , $V_{out} = V_{ref}$	• -23	23	
Load Regulation (Note 1)	R_{LOAD}	$V_{DIFF} = 3.0\text{V}$, 10mA I_L .5A, $T_A = 25^\circ\text{C}$	-15	15	mV
		$V_{DIFF} = 3.3\text{V}$, 10mA I_L .5A	• -15	15	
		$V_{DIFF} = 40\text{V}$, 10mA I_L 150mA, $T_A = 25^\circ\text{C}$	-15	15	
		$V_{DIFF} = 40\text{V}$, 10mA I_L 100mA	• -15	15	
Thermal Regulation	V_{RTH}	$V_{in} = 14.6\text{V}$, $I_L = 300\text{mA}$ $P_d = 4\text{ Watts}$, $t = 20\text{ ms}$, $T_A = 25^\circ\text{C}$	-16	16	mV
Ripple Rejection (Note 2)	R_N	$f = 120\text{ Hz}$, $V_{out} = V_{ref}$ $C_{Adj} = 10\text{ }\mu\text{F}$	• 66		dB
Adjustment Pin Current	I_{Adj}	$V_{DIFF} = 3.0\text{V}$, $T_A = 25^\circ\text{C}$		100	μA
		$V_{DIFF} = 3.3\text{V}$	•	100	
		$V_{DIFF} = 40\text{V}$	•	100	
Adjustment Pin Current Change	I_{Adj}	$V_{DIFF} = 3.0\text{V}$, 10mA I_L .5A, $T_A = 25^\circ\text{C}$	-5	5	μA
		$V_{DIFF} = 3.3\text{V}$, 10mA I_L .5A	• -5	5	
		$V_{DIFF} = 40\text{V}$, 10mA I_L 150mA, $T_A = 25^\circ\text{C}$	• -5	5	
		$V_{DIFF} = 40\text{V}$, 10mA I_L 100mA	• -5	5	
		3.0V V_{DIFF} 40V , $T_A = 25^\circ\text{C}$	-5	5	
		3.3V V_{DIFF} 40V	• -5	5	
Minimum Load Current	I_{Lmin}	$V_{DIFF} = 3.0\text{V}$, $V_{OUT} = 1.4\text{V}$ (forced)		5.0	mA
		$V_{DIFF} = 3.3\text{V}$, $V_{OUT} = 1.4\text{V}$ (forced)	•	5.0	
		$V_{DIFF} = 40\text{V}$, $V_{OUT} = 1.4\text{V}$ (forced)	•	5.0	
Current Limit (Note 2)	I_{CL}	$V_{DIFF} = 15\text{V}$	• .5	1.65	A
		$V_{DIFF} = 40\text{V}$, $T_A = 25^\circ\text{C}$	0.15	.065	

Notes:

1. Load and Line Regulation are specified at a constant junction temperature. Pulse testing with low duty cycle is used. Changes in output voltage due to heating effects must be taken into account separately.
2. If not tested, shall be guaranteed to the specified limits.
3. The • denotes the specifications which apply over the full operating temperature range.

STANDARD APPLICATION

* C_{in} is required if regulator is located an appreciable distance from power supply filter.

** C_o is not needed for stability, however it does improve transient response.

$$V_{out} = 1.25\text{ V} \left(1 + \frac{R_2}{R_1} \right) + I_{Adj} R_2$$

Since I_{Adj} is controlled to less than 100 μA , the error associated with this term is negligible in most applications.

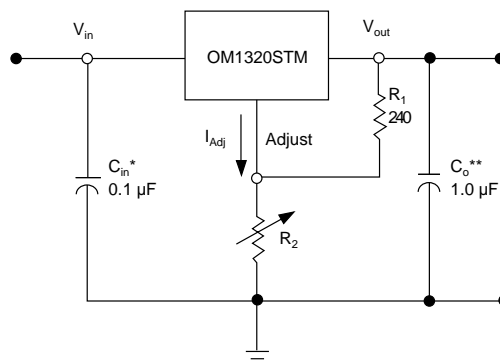

3.5



OM1320NTM, OM1320STM, OM1320NKM, OM1320SMM, OM1320NMM, OM1320N2M

MECHANICAL OUTLINE

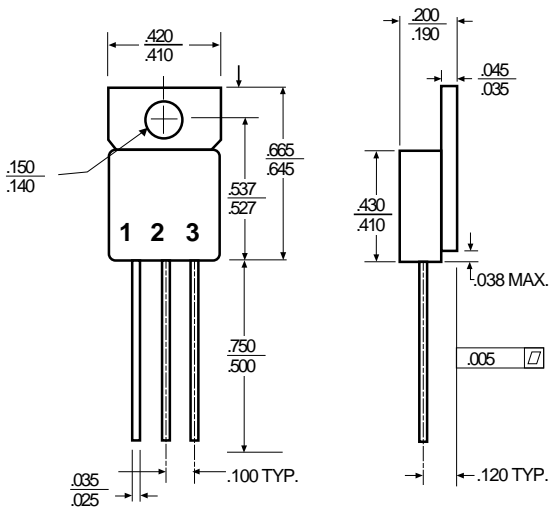

OM1320STM
Isolated
 Front View
 Pin 1 - Adjust
 Pin 2 - Output
 Pin 3 - Input
 Tab - Isolated

OM1320NTM
Non-Isolated
 Front View
 Pin 1 - Adjust
 Pin 2 - Output
 Pin 3 - Input
 Tab - Output

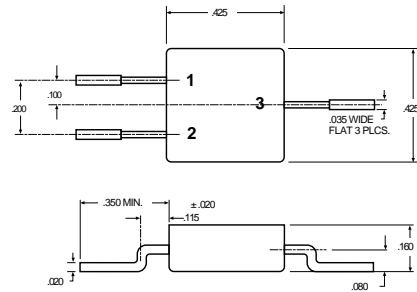

OM1320SMM
 Front View
 Pin 1 - Adjust
 Pin 2 - Input
 Pin 3 - Output
 Case - Isolated

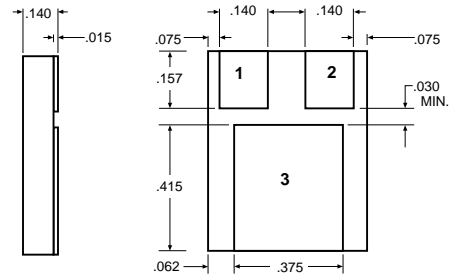

OM1320NMM
 Pin 1 - Adjust
 Pin 2 - Input
 Pin 3 - Output

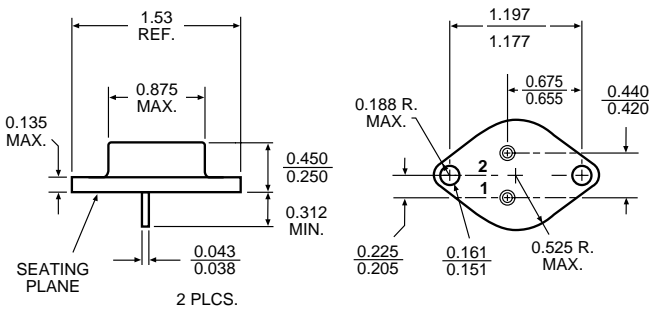

OM1320NKM
 Pin 1 - Adjust
 Pin 2 - Input
 Case - Output

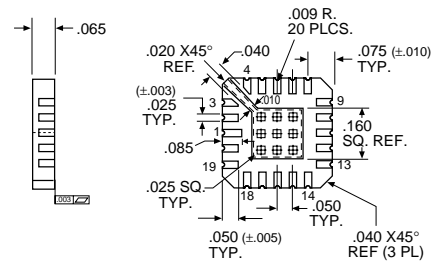

OM1320N2M

Pin 1	V _{OUT} (Sense)	Pin 11	NC
Pin 2	NC	Pin 12	NC
Pin 3	NC	Pin 13	NC
Pin 4	NC	Pin 14	NC
Pin 5	V _{IN}	Pin 15	NC
Pin 6	NC	Pin 16	NC
Pin 7	NC	Pin 17	NC
Pin 8	NC	Pin 18	NC
Pin 9	NC	Pin 19	NC
Pin 10	ADJUST	Pin 20	V _{OUT}

3.5

For additional information please see the mechanical outline section.

