

Description

Quad Pak modules contain the equivalent of four single-channel I/O circuits in a single high-density package. Each Quad Pak module can be divided into two pairs with each pair sharing a common connection. The Quad Pak modules are designed to plug into the Quad Pak high-density I/O mounting racks only and cannot be plugged into single-channel racks. Quad Pak modules are designed to work with a 5 VDC logic voltage only and can be used with Optomux, Pamux, and Mistic protocol brain boards and mounting racks, as well as racks using a direct cable connection to a computer.

DC input modules are used for sensing ON/OFF DC voltage levels. All DC input modules, with the exception of the IDC5BQ, are designed with filtering on the input and a hysteresis amplifier for high noise rejection and transient-free "clean" switching. The IDC5BQ module is a fast-switching input module for signals produced by photoelectric switches, encoders, DC proximity switches, or TTL devices. Each module provides up to 4,000 V_{rms} of optical isolation between field inputs and the logic side of the circuit.

Typical uses and applications include sensing the presence or absence of voltage or sensing contact closures from sources such as:

- Proximity switches
- Limit switches
- Selector switches
- Push button and toggle switches
- Photoelectric switches
- TTL-compatible devices

Part Numbers	Description
IDC5Q	4-Channel DC Input 10–32 VDC, 5 VDC Logic
IDC5BQ	4-Channel DC Input 4–16 VDC, 5 VDC Logic, High Speed
IAC5Q	4-Channel DC Input 90–140 VDC, 5 VDC Logic
IAC5AQ	4-Channel DC Input 180–280 VDC, 5 VDC Logic

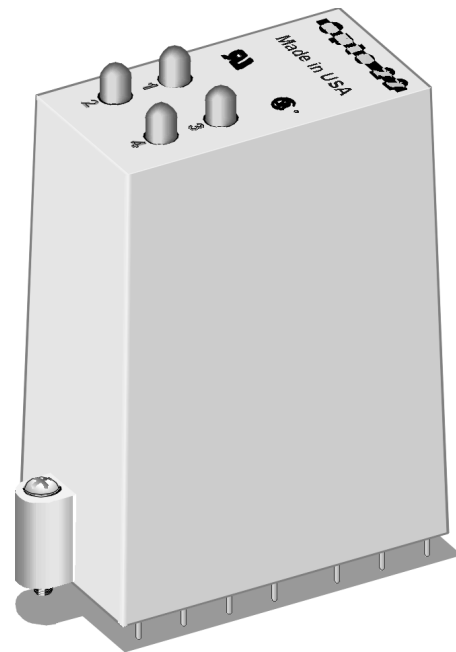

Specifications

GENERAL-Applies To All Models	
Operating Ambient Temperature	-30° to 70° C
Isolation Input-to-Output	4,000 Vrms
Output Voltage Drop	0.4 volts @ 50 milliamperes
Output Current	50 milliamperes
Output Leakage With No Input	100 microamperes maximum @ 30 VDC
Output Transistor	30 volts breakdown

	Units	IDC5Q	IDC5BQ	IAC5Q	IAC5AQ
Input Voltage Range	VDC	10–32	4–16	90–140	180–280
Input Current @ Maximum Line	mA	29	45	11	6.5
Turn-on Time	msec	5	0.05	20	20
Turn-off Time	msec	5	0.01	20	20
Input Allowed For No Output	mA	1	0.7	3	1.7
	V	3	1	45	80
Logic Supply Voltage - Nominal	VDC	5	5	5	5
Logic Supply Voltage Range	VDC	4.5–6	4.5–6	4.5–6	4.5–6
Logic Supply Current @ Nominal Logic Voltage	mA	12	12	12	12
Input Resistance (R ₁ in Schematic Diagram)	Ohms	1.5K	300	24K	66K
Control Resistance (R ₂ in Schematic Diagram)	Ohms	220	220	220	220

OPTO 22

I/O MODULES QUAD DC INPUT

DATA SHEET

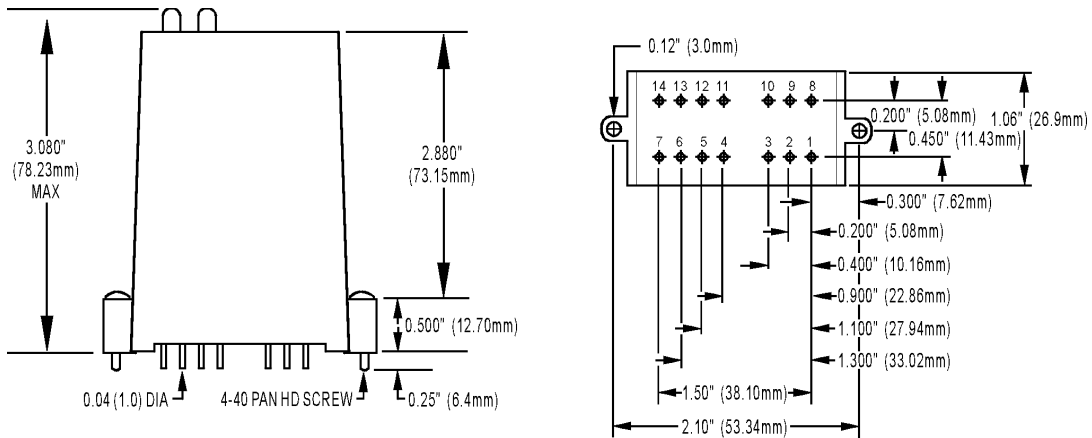

Form 487-040927

Dimensions

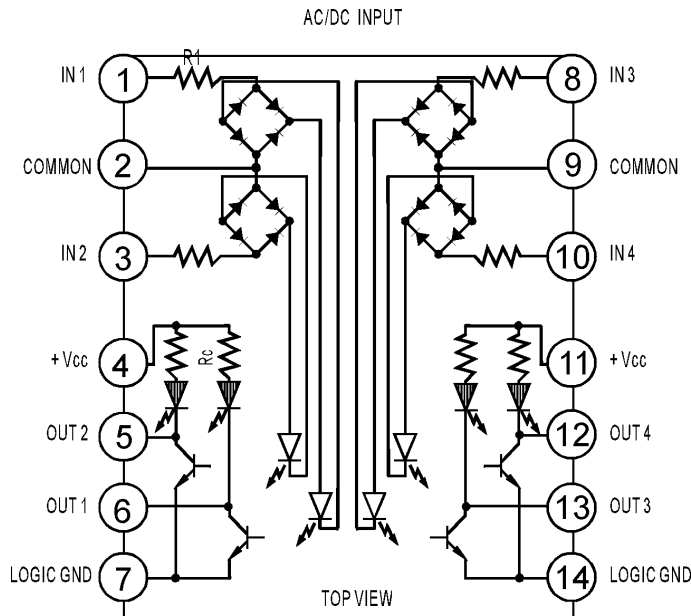

Schematics



-  RED INDICATOR LED
-  INFRARED COUPLER LED
- EQUIVALENT CIRCUIT ONLY
- NEGATIVE TRUE LOGIC