

<b>SILICON BRIDGE RECTIFIERS</b>	<b>REVERSE VOLTAGE</b> - 50 to 1000Volts <b>FORWARD CURRENT</b> - 10/15/25/35/50 Amperes
----------------------------------	---

### FEATURES

- Surge overload -240~500 amperes peak
- Low forward voltage drop
- Mounting position: Any
- Electrically isolated base -2000 Volts
- Solderable 0.25" FAST ON terminals
- Materials used carries U/L recognition

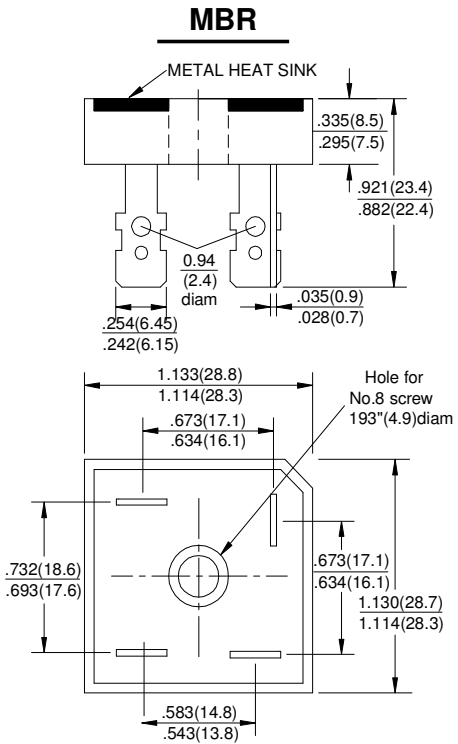

Dimensions in inches and (millimeters)

### MAXIMUM RATINGS AND ELECTRICAL CHARACTERISTICS

Rating at 25°C ambient temperature unless otherwise specified.

Resistive or inductive load 60HZ.

For capacitive load current by 20%

CHARACTERISTICS	SYMBOL	MBR	MBR	MBR	MBR	MBR	MBR	MBR	UNIT
		10005	1001	1002	1004	1006	1008	1010	
		15005	1501	1502	1504	1506	1508	1510	
		25005	2501	2502	2504	2506	2508	2510	
		35005	3501	3502	3504	3506	3508	3510	
		50005	5001	5002	5004	5006	5008	5010	
Maximum Recurrent Peak Reverse Voltage	V <sub>RRM</sub>	50	100	200	400	600	800	1000	V
Maximum RMS Bridge Input Voltage	V <sub>RMS</sub>	35	70	140	280	420	560	700	V
Maximum Average Forward Rectified Output Current @T <sub>c</sub> =55°C	I <sub>(AV)</sub>	10	15	25	35	50			A
Peak Forward Surge Current 8.3ms Single Half Sine-Wave Super Imposed on Rated Load	I <sub>FSM</sub>	240	300	400	400	500			A
Maximum Forward Voltage Drop Per Element at 5.0/7.5/12.5/17.5/25.0 Peak	V <sub>F</sub>	1.1							V
Maximum Reverse Current at Rated DC Blocking Voltage Per Element @T <sub>J</sub> =25°C	I <sub>R</sub>	10.0							μA
Operating Temperature Range	T <sub>J</sub>	-55 to +150							°C
Storage Temperature Range	T <sub>STG</sub>	-55 to +150							°C

**RATING AND CHARACTERISTIC CURVES**  
**MBR10/15/25/35/50A SERIES**



FIG.1-MAXIMUM FORWARD SURGE CURRENT

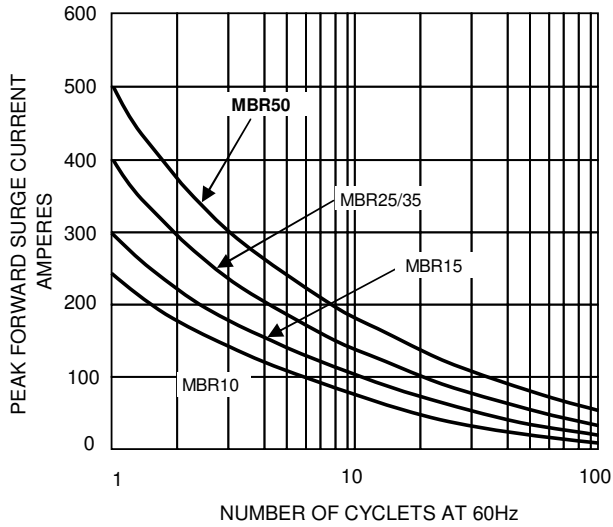

FIG.2- DERATING CURVE  
 OUTPUT RECTIFIED CURRENT

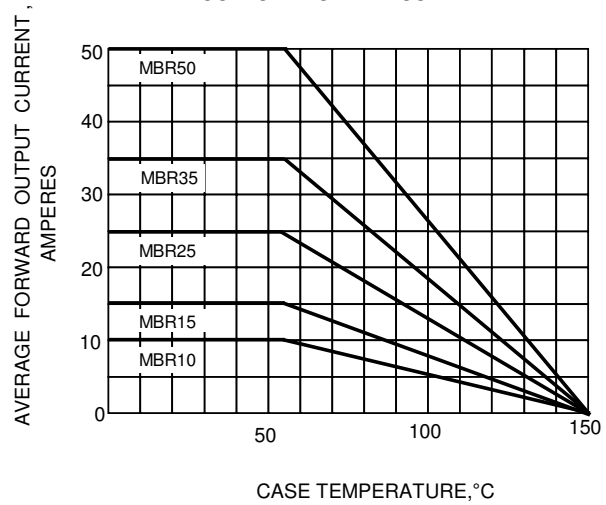

FIG.4-TYPICAL FORWARD CHARACTERISTICS

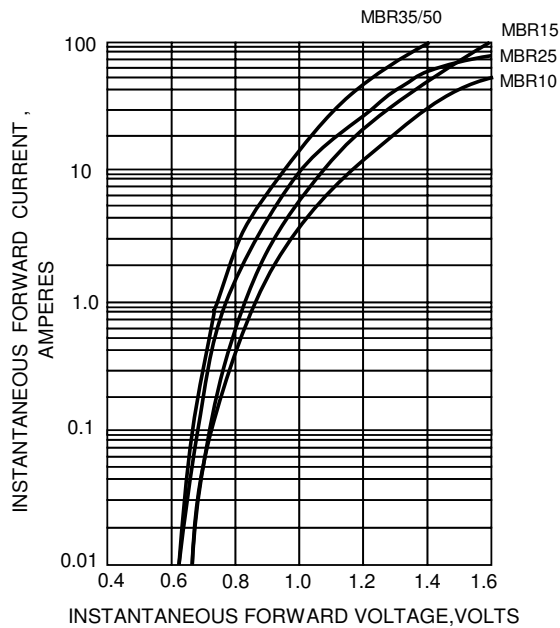

FIG.5-TYPICAL REVERSE CHARACTERISTICS

