

## CPU Frequency Generator

### General Description

The **AV9108** offers a tiny footprint solution for generating two simultaneous clocks. One clock, the REFCLK, is a fixed output frequency which is the same as the input reference crystal (or clock). The other clock, CLK1, can vary between 2 and 120 MHz, with up to 16 selectable preprogrammed frequencies stored in internal ROM.

The **ICS9108** is ideal for use in a 3.3V system. It can generate a 66.66 MHz clock at 3.3V. In addition, the **ICS9108** provides a symmetrical wave form with a worst case duty cycle of 45/55. The **ICS9108** has very tight edge control between the CPU clock and 2XCPU clock outputs, with a worst case skew of 250ps.

The device has advanced features which include on-chip loop filters, tristate outputs, and power-down capability. A minimum of external components - two decoupling capacitors and an optional ferrite bead - are all that are required for jitter-free operation. Standard versions for computer motherboard applications are the **AV9108-03**, **AV9108-05** and the **ICS9108-10**. Custom masked versions, with customized frequencies and features, are available in 6-8 weeks for a small NRE fee.

### Features

- Runs up to 80 MHz at 3.3V
- 50/50 typical duty cycle at 5V
- $\pm 250$ ps absolute jitter
- Generates frequencies from 2 to 140 MHz
- 2 to 32 MHz input reference frequency
- Up to 16 frequencies stored internally
- Patented on-chip Phase Locked Loop with VCO for clock generation
- Provides reference clock and synthesized clock
- On-chip loop filter
- Low power 0.8 $\mu$  CMOS technology
- 8-pin or 14-pin DIP or SOIC package

### Block Diagram

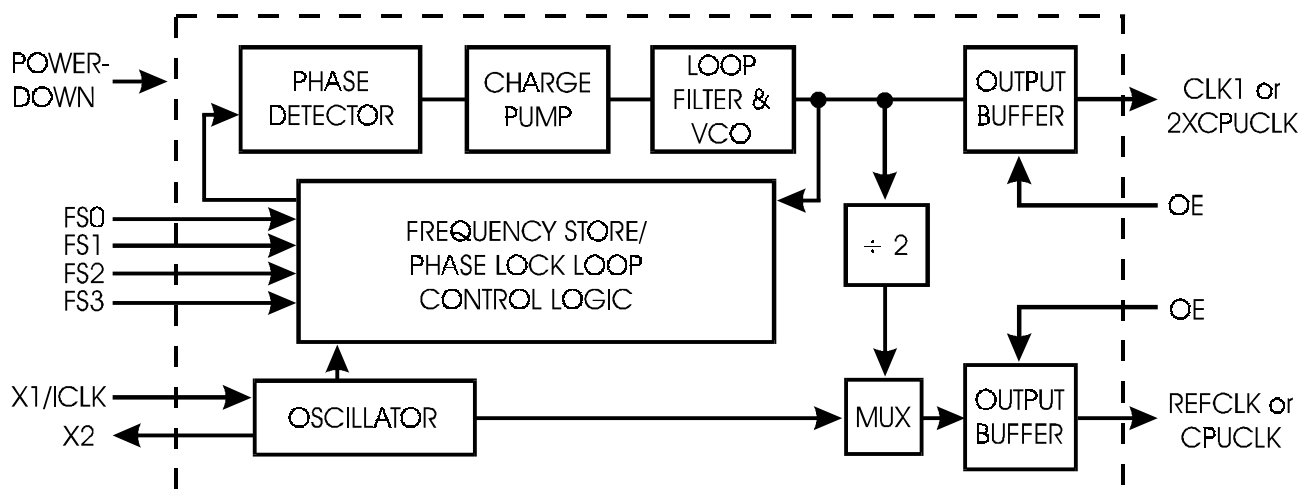



# AV9108

## Pin Configuration

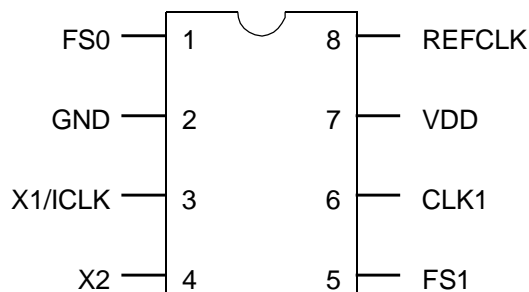

**AV9108-05/-10**  
8-Pin DIP, SOIC

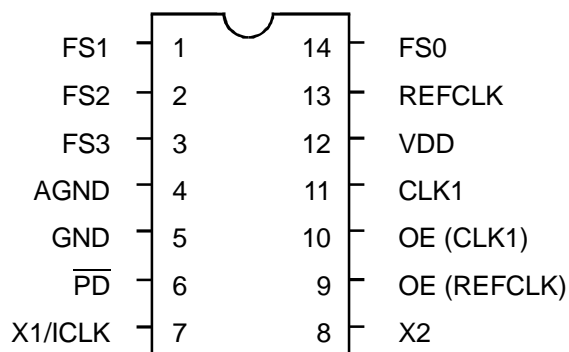

**AV9108-03/-11**  
14-Pin DIP, SOIC

## Pin Descriptions for AV9108-03, AV9108-05 and AV9108-10

PIN NUMBER		PIN NAME	TYPE	DESCRIPTION
-05/-10/-13	-03			
1	14	FS0	Input	Frequency Select 0 for CLK1 (-03 has pull-up).
5	1	FS1	Input	Frequency Select 1 for CLK1 (-03 has pull-up).
	2	FS2	Input	Frequency Select 2 for CLK1 (-03 has pull-up).
	3	FS3	Input	Frequency Select 3 for CLK1 (-03 has pull-up).
	4	AGND	-	Analog GROUND.
2	5	GMD	-	Digital GROUND.
	6	$\overline{PD}$	Input	POWER-DOWN. Shuts off chip when low. Internal pull-up.
3	7	X1/ICLK	Input	CRYSTAL OUTPUT or INPUT CLOCK frequency. Typically 14.318 MHz system clock.
4	8	X2	Output	CRYSTAL OUTPUT (No Connect when clock used.).
	9	OE(REFCLK)	Input	OUTPUT ENABLE. Tristates REFCLK when low. Pull-up.
	10	OE(CLK1)	Input	OUTPUT ENABLE. Tristates CLK1 when low. Pull-up.
6	11	CLK1	Output	CLOCK1 Output (see decoding tables).
7	12	VDD	-	Digital power supply (+3V DC).
8	13	REFCLK	Output	REFERENCE CLOCK output. Produces a buffered version of the input clock or crystal frequency (typically 14.318 MHz).



# AV9108

## Actual Frequencies

**Decoding Table for AV9108-05, 14.318 input**

FS1	FS0	CLK1
0	0	40.01 MHz
0	1	50.11 MHz
1	0	66.61 MHz
1	1	80.01 MHz

**Decoding Table for AV9108-03, 14.318 input**

FS3	FS2	FS1	FS0	CLK1
0	0	0	0	16.00 MHz
0	0	0	1	39.99 MHz
0	0	1	0	50.11 MHz
1	0	1	1	80.01 MHz
0	1	0	0	66.58 MHz
0	1	0	1	100.23 MHz
0	1	1	0	8.02 MHz
0	1	1	1	4.01 MHz
1	0	0	0	8.02 MHz
1	0	0	1	20.00 MHz
1	0	1	0	25.06 MHz
1	0	1	1	40.01 MHz
1	1	0	0	33.29 MHz
1	1	0	1	50.11 MHz
1	1	1	0	4.01 MHz
1	1	1	1	2.05 MHz

**Decoding Table for AV9108-10, 14.318 input**

FS1	FS0	CLK1
0	0	25.057 MHz
0	1	33.289 MHz
1	0	40.006 MHz
1	1	50.113 MHz

**Decoding Table for AV9108-11 (in MHz)**

FS3	FS2	FS1	FS0	CLK1
0	0	0	0	16.00 MHz
0	0	0	1	33.39 MHz
0	0	1	0	50.11 MHz
1	0	1	1	80.01 MHz
0	1	0	0	66.58 MHz
0	1	0	1	100.23 MHz
0	1	1	0	60.00 MHz
0	1	1	1	4.01 MHz
1	0	0	0	8.02 MHz
1	0	0	1	20.05 MHz
1	0	1	0	25.06 MHz
1	0	1	1	39.99 MHz
1	1	0	0	33.25 MHz
1	1	0	1	50.11 MHz
1	1	1	0	30.00 MHz
1	1	1	1	4.01 MHz

Note: The dash number following ICS9108 must be included when ordering product since it specifies the frequency decoding table being ordered. Decoding options can be created by a simple metal mask change.



# AV9108

---

## Frequency Accuracy and Calculation

The accuracy of the frequencies produced by the **ICS9108** depends on the input frequency and the desired actual output frequency. The formula for calculating the exact frequency is as follows:

$$\text{Output Frequency} = \text{Input Frequency} \times \frac{A}{B}$$

where A=2, 3, 4 ... 128, and  
B=2, 3, 4 ... 32.

For example, to calculate the actual output frequency for a video monitor expecting a 44.900 MHz clock and using a 14.318 MHz input clock, the closest A/B ratio is 69/22, which gives an output of 44.906 MHz (within 0.02% of the target frequency). Generally, the **ICS9108** can produce frequencies within 0.1% of the desired output.

## Frequency Transitions

A key **ICS9108** feature is the ability to provide glitch-free frequency transitions across its output frequency range. The **ICS9108** provides smooth transitions between any of the two groups of eight frequencies (when FS3=0 or FS3=1), so that the device will switch glitch-free between 4-100 MHz and 2-50 MHz.

## Allowable Input and Output Frequencies

The input frequency should be between 2 and 32 MHz and the A/B ratio should not exceed 24. The output should fall in the range of 2-120 MHz.

## Output Enable

The Output Enable feature tristates the specified output clock pins. This places the selected output pins in a high impedance state to allow for system level diagnostic testing.

## Power-Down

If equipped, the power-down shuts off the specified PLL or entire chip to save current. A few milliseconds are required to reach full functioning speed from a power-down state.



### Absolute Maximum Ratings

- AVDD, VDD referenced to GND . . . . . 7V
- Operating temperature under bias . . . . . 0°C to +70°C
- Storage temperature . . . . . -65°C to +150°C
- Voltage on I/O pins referenced to GND . . . . . GND -0.5V to VDD +0.5V
- Power dissipation . . . . . 0.5 Watts

Stresses above those listed under Absolute Maximum Ratings may cause permanent damage to the device. This is a stress rating only and functional operation of the device at these or any other conditions above those indicated in the operational sections of the specifications is not implied. Exposure to absolute maximum rating conditions for extended periods may affect product reliability.

### Electrical Characteristics at 5V

(Operating V<sub>DD</sub> = +4.5V to +5.5V; T<sub>A</sub> = 0°C to 70°C unless otherwise stated)

DC Characteristics						
PARAMETER	SYMBOL	TEST CONDITIONS	MIN	TYP	MAX	UNITS
Input Low Voltage	V <sub>IL</sub>		-	-	0.8	V
Input High Voltage	V <sub>IH</sub>		2.0	-	-	V
Input Low Current	I <sub>IL</sub>	V <sub>IN</sub> =0V	-	6.0	16	μA
Input High Current	I <sub>IH</sub>	V <sub>IN</sub> =V <sub>DD</sub>	-2.0	-	2.0	μA
Output Low Voltage	V <sub>OL</sub>	I <sub>OL</sub> =10mA	-	0.15	0.40	V
Output High Voltage, Note 1	V <sub>OH</sub>	I <sub>OH</sub> =-30mA	2.4	3.25	-	V
Output Low Current, Note 1	I <sub>OL</sub>	V <sub>OL</sub> =0.8V	22.0	35.0	-	mA
Output High Current, Note 1	I <sub>OH</sub>	V <sub>OH</sub> =2.0V	-	-50.0	-35.0	mA
Supply Current	I <sub>CC</sub>	Unload, 50 MHz	-	18.0	42.0	mA
Supply Current	I <sub>CC</sub> (PD low)	Unload, Logic Inputs 000	-	38.0	100.0	μA
Supply Current	I <sub>CC</sub> (PD low)	Unload, Logic Inputs 111	-	14.0	40.0	μA
Pull-up Resistor, Note 1	R <sub>pu</sub>		-	380.0	700.0	k ohms
AC Characteristics						
Rise Time 0.8 to 2.0V, Note 1	T <sub>r</sub>	15pf load	-	0.60	1.40	ns
Fall Time 2.0 to 0.8V, Note 1	T <sub>f</sub>	15pf load	-	0.40	1.00	ns
Rise Time 20% to 80%, Note 1	T <sub>r</sub>	15pf load	-	2.0	3.5	ns
Fall Time 80% to 20%, Note 1	T <sub>f</sub>	15pf load	-	1.0	2.5	ns
Duty Cycle, Note 1	D <sub>t</sub>	15pf load @ 1.4V	45.0	50.0	55.0	%
Jitter, One Sigma, Note 1	T <sub>jis</sub>	From 20 to 100 MHz	-	50.0	150.0	ps
Jitter, One Sigma, Note 1	T <sub>jis</sub>	From 14 to 16 MHz	-	100.0	200.0	ps
Jitter, One Sigma, Note 1	T <sub>jis</sub>	From 14 to Below	-	0.2	1.0	%
Jitter, Absolute, Note 1	T <sub>jab</sub>	From 20 to 100 MHz	-250.0	-	250.0	ps
Jitter, Absolute, Note 1	T <sub>jab</sub>	From 14 to 16 MHz	-500.0	-	500.0	ps
Jitter, Absolute, Note 1	T <sub>jab</sub>	From 14 to Below	-	1.0	3.0	%
Input Frequency, Note 1	F <sub>i</sub>		11.0	14.3	19.0	MHz
Output Frequency	F <sub>o</sub>		2.0	-	120.0	MHz
Power-up Time, Note 1	T <sub>pu</sub>		-	7.58	18.0	ms
Transition Time, Note 1	T <sub>ft</sub>	8 to 66.6 MHz	-	6.0	13.0	ms

Note 1: Parameter is guaranteed by design and characterization. Not 100% tested in production.



# AV9108

## Electrical Characteristics at 3.3V

(Operating  $V_{DD} = +3.0V$  to  $+3.7V$ ;  $T_A = 0^\circ C$  to  $70^\circ C$  unless otherwise stated)

DC Characteristics						
PARAMETER	SYMBOL	TEST CONDITIONS	MIN	TYP	MAX	UNITS
Input Low Voltage	$V_{IL}$		-	-	$0.20V_{DD}$	V
Input High Voltage	$V_{IH}$		$0.7V_{DD}$	-	-	V
Input Low Current	$I_{IL}$	$V_{IN}=0V$	-	2.5	7.0	$\mu A$
Input High Current	$I_{IH}$	$V_{IN}=V_{DD}$	-2.0	-	2.0	$\mu A$
Output Low Voltage	$V_{OL}$	$I_{OL}=6mA$	-	0.15	0.1	V
Output High Voltage	$V_{OH}$	$I_{OH}=-5mA$	0.85	0.92	-	V
Output Low Current	$I_{OL}$	$V_{OL}=0.2V_{DD}$	15.0	22.0	-	mA
Output High Current	$I_{OH}$	$V_{OL}=0.7V_{DD}$	-	-17.0	-10.0	mA
Supply Current	$I_{CC}$	Unloaded, 50 MHz	-	22.0	40.0	mA
Supply Current	$I_{CC}$ (PD low)	Unload, Logic Inputs 000	-	13.0	40.0	$\mu A$
Supply Current	$I_{CC}$ (PD low)	Unload, Logic Inputs 111	-	4.0	12.0	$\mu A$
Pull-up Resistor	$R_{pu}$		-	550.0	900.0	k ohms
AC Characteristics						
Rise Time 20% to 80%, Note 1	$T_r$	15pf load	-	2.2	3.5	ns
Fall Time 80% to 20%	$T_f$	15pf load	-	1.2	2.5	ns
Duty Cycle	$D_t$	15pf load @ 50%	40.0	46.0	60.0	%
Jitter, One Sigma	$T_{jis}$	From 25 to 85 MHz	-	50.0	150.0	ps
Jitter, One Sigma	$T_{jis}$	From 14 to 20 MHz	-	100.0	200.0	ps
Jitter, One Sigma	$T_{jis}$	From 14 to Below	-	0.4	1.0	%
Jitter, Absolute	$T_{jab}$	From 25 to 85 MHz	-250.0	-	250.0	ps
Jitter, Absolute	$T_{jab}$	From 14 to 20 MHz	-500.0	-	500.0	ps
Jitter, Absolute	$T_{jab}$	From 14 to Below	-	1.0	3.0	%
Input Frequency	$F_i$		13.3	14.3	15.3	MHz
Output Frequency	$F_o$		2.0	-	90.0	MHz
Power-up Time, Note 1	$T_{pu}$		-	7.58	18.0	ms
Transition Time, Note 1	$T_{ft}$	8 to 66.6 MHz	-	6.0	13.0	ms

Parameter is guaranteed by design and characterization.

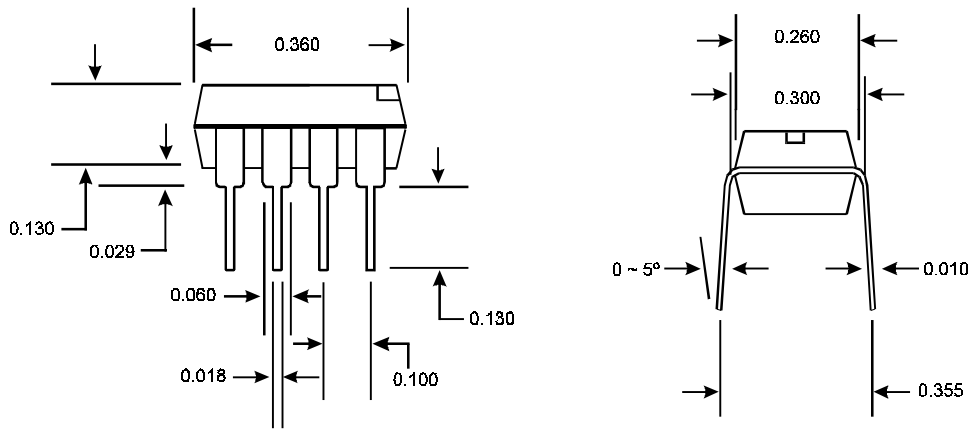

8-Pin DIP Package

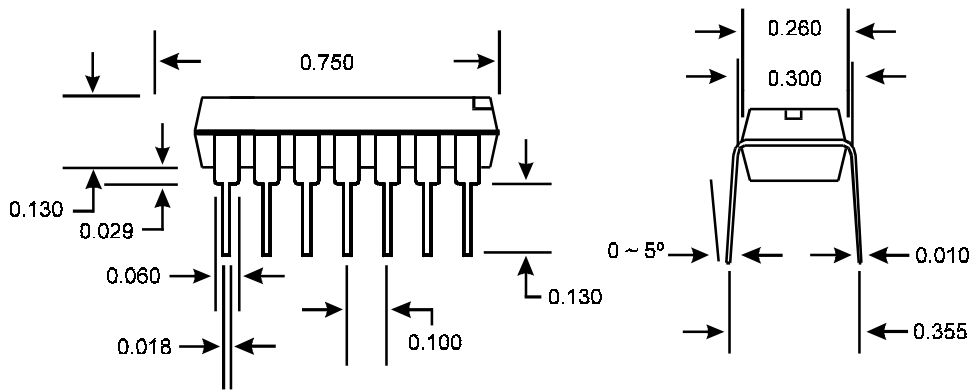

14-Pin DIP Package

### Ordering Information

AV9108-XXCN8, ICS9108-XXCN14

Example:

**XXX XXXX- XX M X#W**

- Lead Count & Package Width**  
Lead Count=1, 2 or 3 digits  
W=.3" SOIC or .6" DIP; None=Standard Width
- Package Type**  
N=DIP (Plastic)
- Pattern Number (2 or 3 digit number for parts with ROM code patterns)**
- Device Type (consists of 3 or 4 digit numbers)**
- Prefix**  
ICS, AV=Standard Device; GSP=Genlock Device

# AV9108

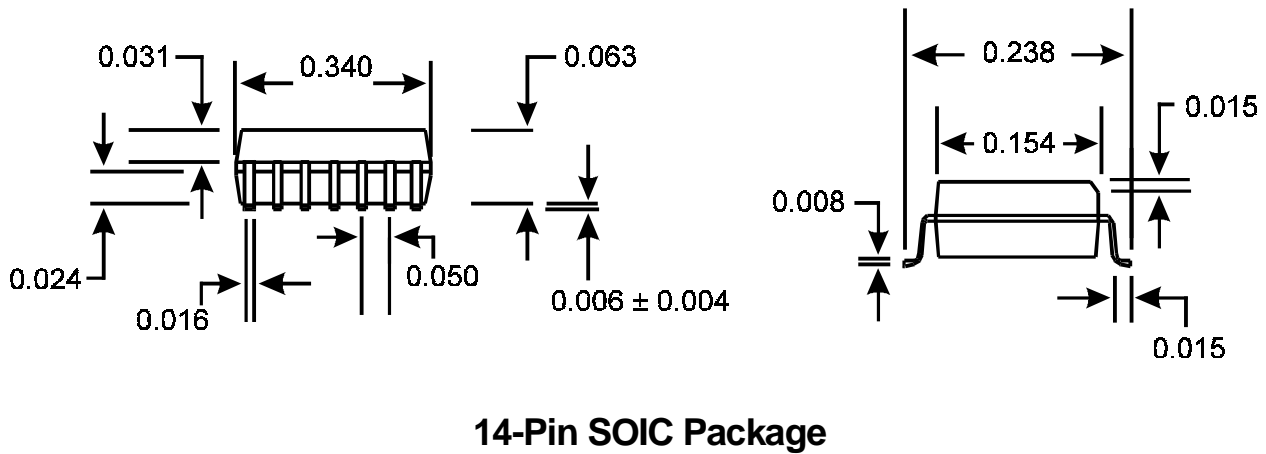
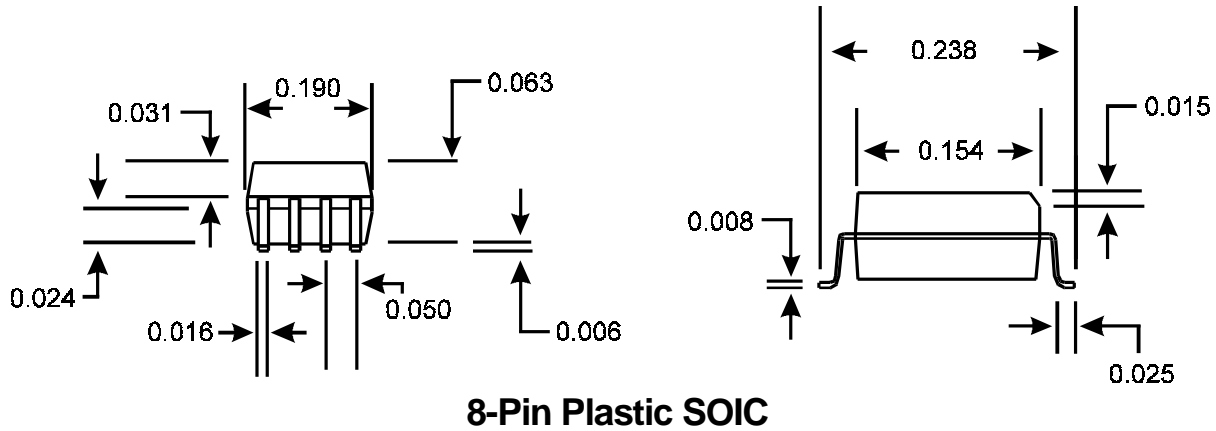

## Ordering Information

ICS9108-XXCS8, IS9108-XXCS14

Example:

**XXX XXXX- XX M X#W**

