

Fibre Optic LAN Components

VCSEL + BMPD

Honeywell
HFE4083-322/XBA

FEATURES

- High speed low cost VCSEL.
- Industry standard ST-LP fibre connector.
- Designed for drive currents between 5 and 15mA
Optimised for low temperature dependence

DESCRIPTION

The HFE4083-322/XBA is a high-performance 850nm VCSEL (vertical cavity surface emitting laser) packaged for high speed communications. This product combines all the performance advantages of the VCSEL with a custom designed power monitor diode. The power monitor diode can be used with appropriate feedback control circuitry to set a maximum power level for each VCSEL, simplifying design for high data rate communication and eye safety. It combines many of the desirable features of an LED with the desirable features of a laser diode, operating in a single longitudinal mode but with multiple transverse modes reducing coherence and consequent modal noise in multimode fibre applications.

APPLICATION

The HFE4083-322/XBA is a high radiance VCSEL packaged in an ST PCB mounting housing. The ST optical port enables efficient and convenient coupling of the optical power into a fibre network.

The component produces a circularly symmetric, narrow divergence beam. The HFE4083-322/XBA is designed to be used with inexpensive silicon or gallium arsenide detectors, but excellent performance can also be achieved with some indium gallium arsenide detectors.

The low drive current of the HFE4083-322/XBA makes direct drive from PECL or ECL logic gates feasible and eases driver design.

Fibre Optic LAN Components VCSEL + BMPD

Honeywell
HFE4083-322/XBA

ABSOLUTE MAXIMUM RATINGS

Storage temperature	-40 to +100°C
Operating temperature	0 to +70°C
Forward current	15mA
Reverse voltage	5V @ 10µA

NOTICE

Stresses greater than those listed under “Absolute Maximum Ratings” may cause permanent damage to the device. This is a stress rating only and functional operation of the device at these or any other conditions above those indicated in the operations section for extended periods of time may affect reliability.

ELECTRO-OPTICAL CHARACTERISTICS (Tests made at 25°C unless otherwise stated)

Parameter	Symbol	Min.	Typ.	Max.	Units	Test Conditions
Peak Operating Current	I_{PEAK}		12	20	mA	Adjustable to establish operating power
Optical output power	P_O	200 -7.0	500 -3.0	1000 0.0	µW dBm	$I_F = 10mA$ 50/125
Threshold Current	I_{TH}		3.6	6	mA	
Threshold current temperature variation	ΔI_{TH}	-1		1	mA	$T_A = 0^\circ C$ to $70^\circ C$
Slope Efficiency	η	0.1	0.2	0.4	mW/mA	$P_o = 1.3mW$
Slope efficiency temperature variation.	$\Delta\eta/\Delta T$		-0.4		%/°C	$T_A = 0^\circ C$ to $70^\circ C$
Peak Wavelength	λ_P	830	850	860	nm	$I_F = 12mA$ DC
λ_P Temperature variation	$\Delta\lambda/\Delta T$		0.06		nm/°C	$I_F = 12mA$ DC
Spectral Bandwidth	$\Delta\lambda$			0.85	nm	$I_F = 12mA$ DC
Laser forward voltage	V_F	1.6	1.75	2.2	V	$I_F = 12mA$ DC
Laser reverse voltage	BVR_{LD}	5	10		V	$I_R = 10\mu A$
Rise / fall time	t_R/t_F		100	300	pS	Bias above threshold (20% - 80%)
Relative intensity noise	RIN		-128	-122	dB/Hz	1GHz BW
Series Resistance	r_S	15	25	50	Ω	$I_F = 12mA$ DC
Monitor current	I_{PD}	0.020		0.044	mA	$P_o = 1.3mW$
Monitor current temperature variation	$\Delta I_{PD}/\Delta T$		0.2		%/°C	$P_o = 0.5mW$
Dark current	I_D			20	nA	$P_o = 0mW$, $V_R = 3V$
PD reverse voltage	BVR_{PD}	30	115		V	$P_o = 0mW$, $I_R = 10\mu A$
PD capacitance	C		100 55		pF	$V_R = 0V$, $F = 1MHz$ $V_R = 3V$, $F = 1MHz$

Fibre Optic LAN Components

VCSEL + BMPD

Honeywell

HFE4083-322/XBA

NOTICE

The inherent design of this component causes it to be sensitive to electrostatic discharge (ESD). To prevent ESD-induced damage and/or degradation to equipment, take normal ESD precautions when handling this product.

MOUNTING DIMENSIONS (for reference only)

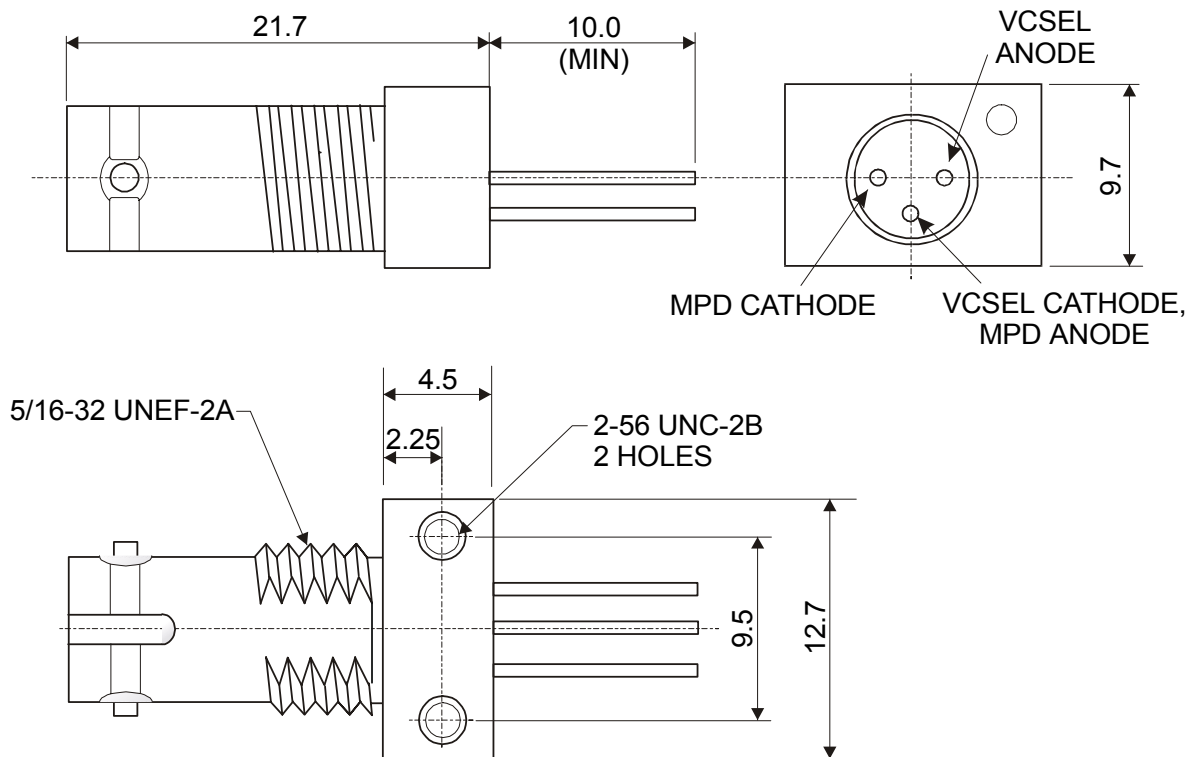

SALES AND SERVICE

Honeywell serves its customers through a world-wide network of sales offices and distributors. For application assistance, current specifications, pricing or name of the nearest Authorised Distributor, contact a nearby sales office or call:

+44 (0)1698 481735 UK

INTERNET

<http://www.honeywell.sensing.com>

info@micro.honeywell.com

Specifications may change at anytime and without notice. The information we supply is believed to be accurate and reliable as of this printing. However, we assume no responsibility for its use.

While we provide application assistance, personally and through our literature, it is up to the customer to determine the suitability of the product in the application.