

Subminiature Time Counters With Enhanced Appearance and Features

- Large display with 8.6 mm (0.338 in) height
- Available with backlit LCD
- PNP/NPN DC voltage input available
- Seven digits, time range 0 to 3999d23.9h
- Key-protect switch to prevent front resetting
- Selectable time range: 999999.9h or 3999d23.9h and 999h59m59s or 9999h59.9m
- NEMA 4/IP66 front
- Replaceable battery
- New black case



Ordering Information

■ TIME COUNTERS

Count input	Display	Time range	
		999999.9h or 3999d23.9h (selectable)	999h59m59s or 9999h59.9m (selectable)
PNP/NPN universal DC voltage input	7-segment LCD with backlight	H7ET-NV-BH	H7ET-NV1-BH
	7-segment LCD	H7ET-NV-B	H7ET-NV1-B
AC/DC multi-voltage input	7-segment LCD	H7ET-NFV-B	H7ET-NFV1-B
No-voltage input	7-segment LCD	H7ET-N-B	H7ET-N1-B

■ MODEL NUMBER LEGEND

H7ET - N -
1 2 3 4

1. Count Input

None: No-voltage input
 V: PNP/NPN universal DC voltage input
 FV: AC/DC multi-voltage input

2. Time Range

None: 999999.9h/3999d23.9h
 1: 999h59m59s/9999h59.9m

3. Case Color

B: Black

4. Display

None: 7-segment LCD without backlight
 H: 7-segment LCD with backlight

■ ACCESSORIES (ORDER SEPARATELY)

Item	Part number
Replacement battery	Y92S-36
Wire-wrap terminal (set of two terminals)	Y92S-37
Panel-mounting adapter	26 mm × 45 mm
	24.8 mm × 48.8 mm
	Y92F-75
	Y92F-77B

Specifications

■ GENERAL

Item	H7ET-NV-B H7ET-NV-BH	H7ET-NFV-B	H7ET-N-B	H7ET-NV1-B H7ET-NV1-BH	H7ET-NFV1-B	H7ET-N1-B
Operating mode	UP type					
Mounting method	Panel mounting					
External connections	Screw terminals, optional wire-wrap terminals (See Note 3.)					
Reset	External/Manual reset					
Display	7-segment LCD with or without backlight (character height: 8.6 mm) (See Note 1.)					
Number of digits	7					
Time range	0.0h to 999999.9h or 0.0h to 3999d23.9h (switchable with switch)			0s to 999h59m59s or 0.0m to 9999h59.9m (switchable with switch)		
Count input	PNP/NPN universal DC voltage input	AC/DC multi-voltage input	No-voltage input	PNP/NPN universal DC voltage input	AC/DC multi-voltage input	No-voltage input
Case color	Black					
Attachment	Waterproof gasket, panel-mounting bracket, time unit labels (See Note 2.)					
Approved standard	UL508, CSA C22.2 No.14, Lloyds Conforms to EN61010-1/IEC61010-1 (pollution degree2/overvoltage category III) Conforms to VDE0106/P100					

- Note: 1. Only PNP/NPN universal DC voltage input models (-H models) are available with a backlight.
 2. "-hours," "-d-h," "-h-m," and "-h-m-s" labels are included.
 3. Wire-wrap terminals (Y92S-37) can be ordered separately.

■ RATINGS

Item	H7ET-NV□-B, H7ET-NV□-BH	H7ET-NFV□-B	H7ET-N□-B
Supply voltage	Backlight model: 24 VDC (for backlight) No-backlight model: Not required (powered by battery)	Not required (powered by battery)	
Count input	High (logic) level: 4.5 to 30 VDC Low (logic) level: 0 to 2 VDC (Input impedance: Approx. 4.7 kΩ)	High (logic) level: 24 to 240 VAC/ VDC, 50/60 Hz Low (logic) level: 0 to 2.4 VAC/ VDC, 50/60 Hz	No voltage input Maximum short-circuit impedance: 10 kΩ max. Short-circuit residual voltage: 0.5 V max. Minimum open impedance: 750 kΩ min.
Reset input		No voltage input Maximum short-circuit impedance: 10 kΩ max. Short-circuit residual voltage: 0.5 V max. Minimum open impedance: 750 kΩ min.	
Minimum pulse width	1 s		
Reset system	External reset and manual reset: minimum signal width of 20 ms		
Terminal screw tightening torque	0.98 N • m max.		
Ambient temperature	Operating: -10°C to 55°C (14°F to 131°F) with no condensation or icing Storage: -25°C to 65°C (-13°F to 149°F) with no condensation or icing		
Ambient humidity	Operating: 25% to 85%		

■ CHARACTERISTICS

Item	H7ET-NV□-□ H7ET-NV□-H□	H7ET-NFV□-□	H7ET-N□-□
Time accuracy	±100 ppm (25°C)		
Insulation resistance	100 MΩ min. (at 500 VDC) between current-carrying metal parts and exposed non-current-carrying metal parts, and between the backlight power supply and count input terminals/reset terminals for backlight models	100 MΩ min. (at 500 VDC) between current-carrying metal parts and exposed non-current-carrying metal parts and between count input terminals and reset terminals	100 MΩ min. (at 500 VDC) between current-carrying metal parts and exposed non-current-carrying metal parts
Dielectric strength	1,000 VAC, 50/60 Hz for 1 min between current-carrying metal parts and exposed non-current-carrying metal parts and between the backlight power supply and count input terminals/reset terminals for backlight models	3,700 VAC, 50/60 Hz for 1 min between count input terminals and exposed non-current-carrying metal parts 2,200 VAC, 50/60 Hz for 1 min between reset terminals and exposed non-current-carrying metal parts and between count input terminals and reset terminals	1,000 VAC, 50/60 Hz for 1 min between current-carrying metal parts and exposed non-current-carrying metal parts
Impulse withstand voltage	4.5 kV between current-carrying terminal and exposed non-current-carrying metal parts	4.5 kV between current-carrying terminal and exposed non-current-carrying metal parts 3 kV between input terminals and reset terminals	4.5 kV between current-carrying terminal and exposed non-current-carrying metal parts
Noise immunity	Between input terminals: ±600 V in normal mode, ±1.5 kV in command mode For backlight power supply (backlight model): ±480 V in normal mode, ±1.5 kV in command mode	Between count input terminals: ±1.5 kV in normal mode, ±1.5 kV in command mode Between reset input terminals: ±500 V in normal mode, ±1.5 kV in command mode	±500 V in normal mode, ±1.5 kV in command mode
Static immunity	±8 kV (malfunction)		
Vibration resistance	Malfunction: 0.15-mm single amplitude at 10 to 55 Hz for 10 min each in 3 directions Destruction: 0.375-mm single amplitude at 10 to 55 Hz for 2 hrs each in 3 directions		
Shock resistance	Malfunction: 200 m/s ² {approx. 20G} 3 times each in 6 directions Destruction: 300 m/s ² {approx. 30G} 3 times each in 6 directions		
Battery life	10 years min. with continuous input at 25°C (lithium battery)		
EMC	(EMI) Emission Enclosure: (EMS) Immunity ESD: Immunity RF-interference from AM Radio Waves: Immunity RF-interference from Pulse-modulated Radio Waves: Immunity Conducted Disturbance: Immunity Burst:	EN50081-1 EN55022 class B EN50082-2 EN61000-4-2: 4-kV contact discharge (level 2) 8-kV air discharge (level 3) ENV50140: 10 V/m (80 MHz to 1 GHz) (level 3) ENV50204: 20 V/m (900 MHz ± 5 MHz) (level 3) ENV50141: 10 V (0.15 to 80 MHz) (level 3) EN61000-4-4: 2-kV power line (level 3) 2-kV I/O signal line (level 4)	
Enclosure rating	Front panel: IP66, NEMA4 with waterproof packing Terminal block: IP20		
Weight (see note)	Non-backlight model: Approx. 60 g Backlight model: Approx. 65 g	Approx. 60 g	Approx. 60 g

Note: Weight includes waterproof gasket and panel-mounting bracket.

Nomenclature

TIME COUNTER

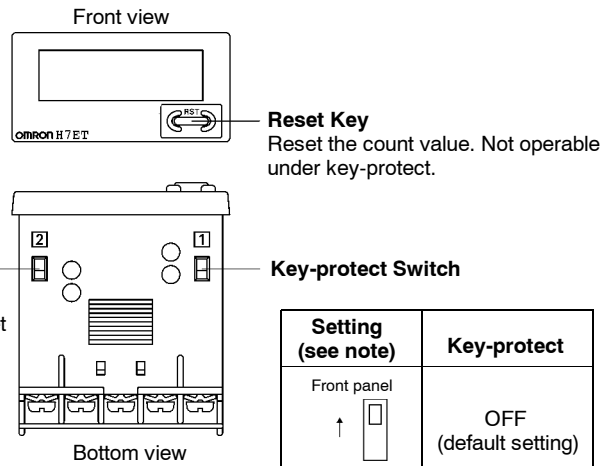

Setting (see note)	Time range	
	H7ET-N□□-□□	H7ET-N□□1-□□
Front panel 	0.0h to 3999d23.9h (default setting)	0s to 999h59m59s (default setting)
Terminal block 	0.0h to 999999.9h	0.0m to 9999h59.9m

Setting (see note)	Key-protect
Front panel 	OFF (default setting)
Terminal block 	ON

Note: Perform switch setting before mounting to a control panel.

Operation

OPERATING MODES

H7ET Time Counter

Incrementing Operation (Up)

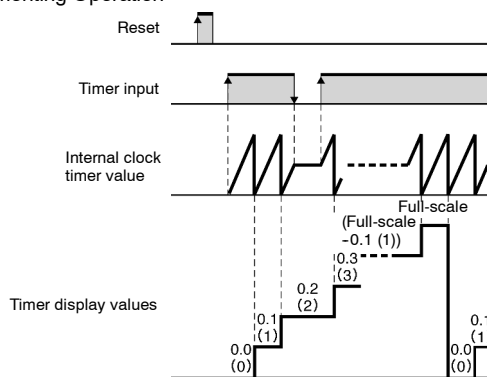

Dimensions

Unit: mm (inch)

■ H7ET-N

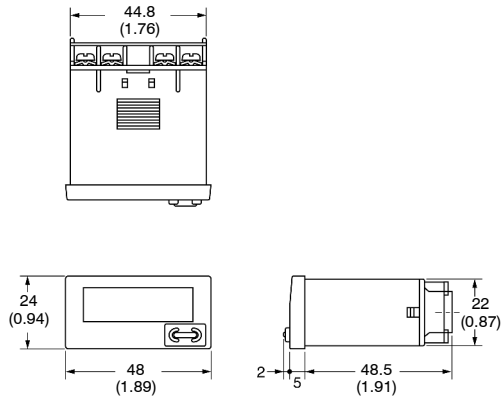
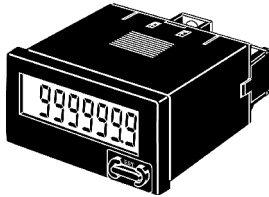

Panel Cutout

Separate mounting

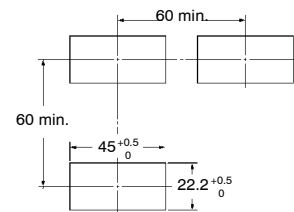

Joint mounting

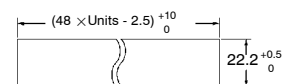

Waterproofing is not possible for joint mounting

- When mounting, insert the Counter into the cutout. Insert the adapter from the back and push in the Counter while making the gap between the front panel and the cutout panel as small as possible. Use screws to secure the Counter. If waterproofing is desired, insert the waterproof gasket.
- When several Counters are installed, ensure that the ambient temperature will not exceed specifications.
- The appropriate thickness of the panel is 1 to 5 mm.

Dimensions with Panel-Mounting Bracket

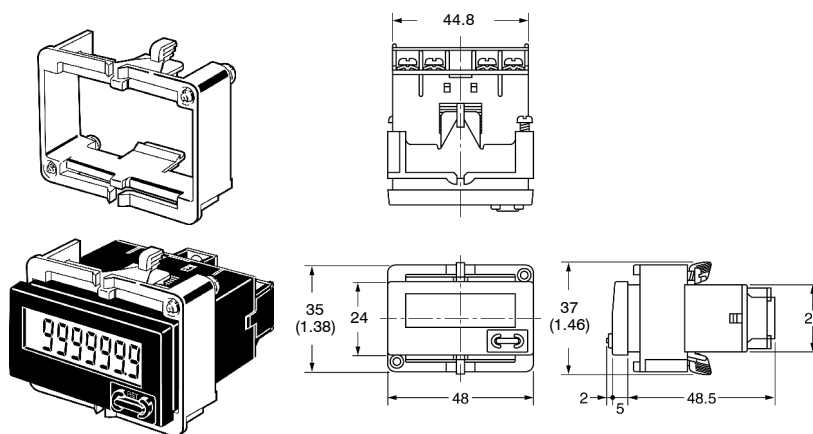

Installation

■ TERMINAL ARRANGEMENT

Bottom view: View of the Time Counter rotated horizontally 180°

Backlight Model

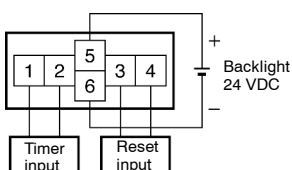

Non-backlight Model

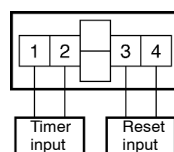

Connections

■ PNP/NPN UNIVERSAL DC VOLTAGE INPUT MODEL WITH BACKLIGHT

1. Contact Input (Input by a Relay or Switch Contact)

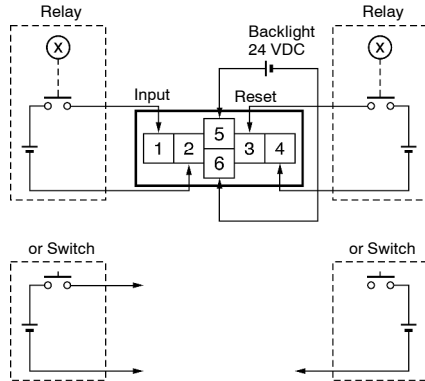

2. Solid-state Input

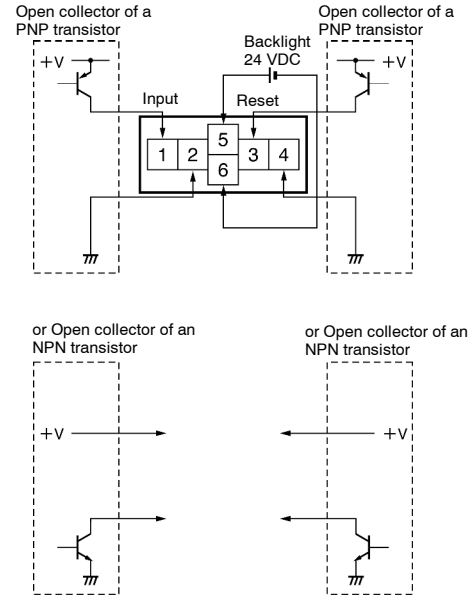

- Note:**
1. Terminals 2 and 4 (input circuit and reset circuit) are functionally isolated.
 2. Select input transistors according to the following:
Dielectric strength of the collector ≥ 50 V
Leakage current $< 1 \mu\text{A}$

PNP/NPN UNIVERSAL DC VOLTAGE INPUT MODEL WITHOUT BACKLIGHT

1. Contact Input (Input by a Relay or Switch Contact)

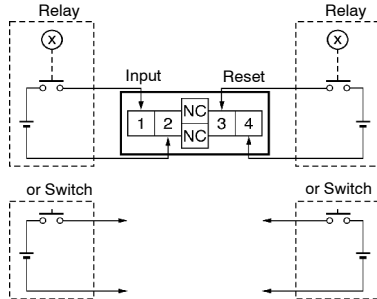

2. Solid-state Input

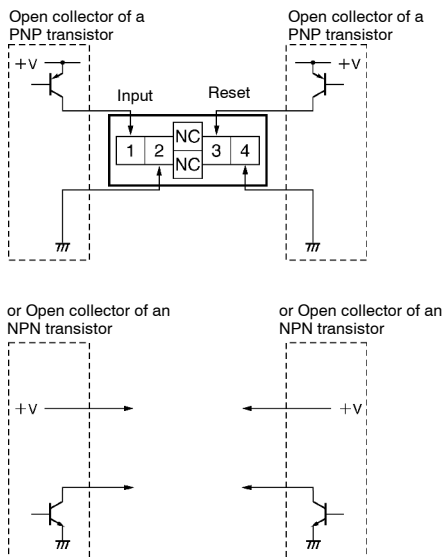

- Note: 1. Terminals 2 and 4 (input circuit and reset circuit) are functionally isolated.
 2. Select input transistors according to the following:
 Dielectric strength of the collector ≥ 50 V
 Leakage current $< 1 \mu\text{A}$

AC/DC MULTI-VOLTAGE INPUT MODEL

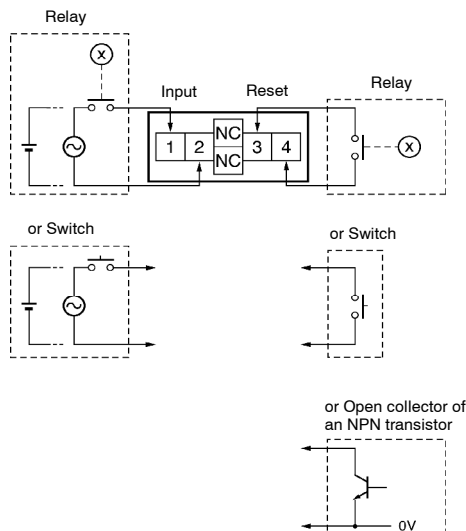

NO-VOLTAGE INPUT MODEL

1. Contact Input (Input by a Relay or Switch Contact)

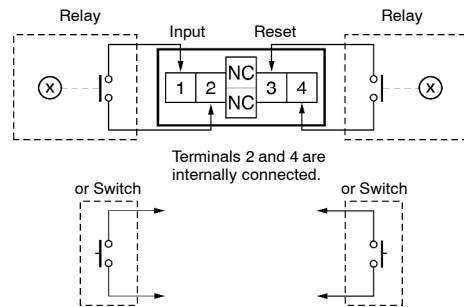

Note: Use Relays and Switches that have high contact reliability because the current flowing from terminals 1 or 3 is as small as approx. $10 \mu\text{A}$. OMRON's G3TA-IA/ID is recommended as the SSR.

2. Solid-state Input (Open Collector Input of an NPN Transistor)

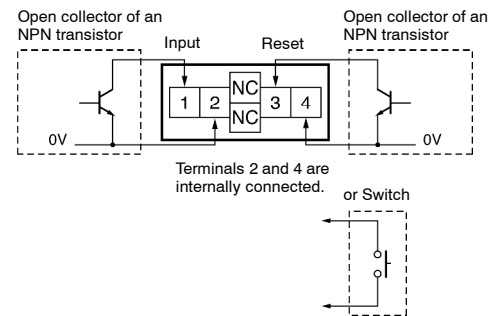

- Note: 1. Residual voltage in the output section of Proximity Sensors or Photoelectric Sensors becomes less than 0.5 V because the current flowing from terminals 1 or 3 is as small as approx. $10 \mu\text{A}$, allowing easy connection.
 2. Select input transistors according to the following:
 Dielectric strength of the collector ≥ 50 V
 Leakage current $< 1 \mu\text{A}$

Accessories (Order Separately)

An H7ET is supplied with a mounting bracket and nut. In addition, the panel-mounting adapters shown here allow the H7ET to be fitted to existing panel cutouts.

Y92F-75 PANEL-MOUNTING ADAPTER FOR 26 × 45 RECTANGULAR CUTOUT

Must be used with mounting bracket supplied with the Counter

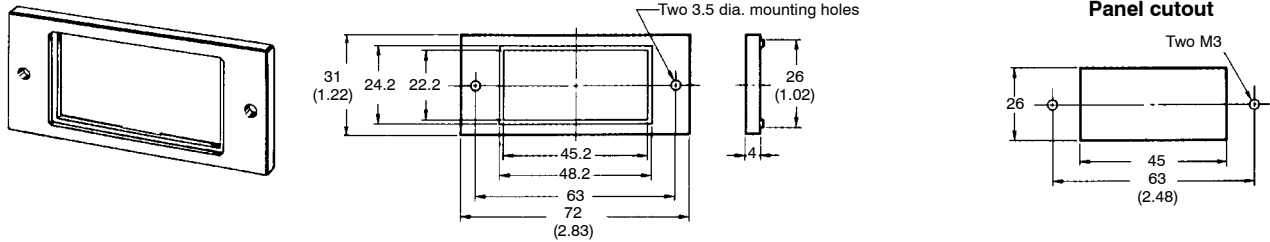

Y92F-77B PANEL-MOUNTING ADAPTER FOR 24.8 × 48.8 RECTANGULAR CUTOUT

Must be used with mounting bracket supplied with the Counter

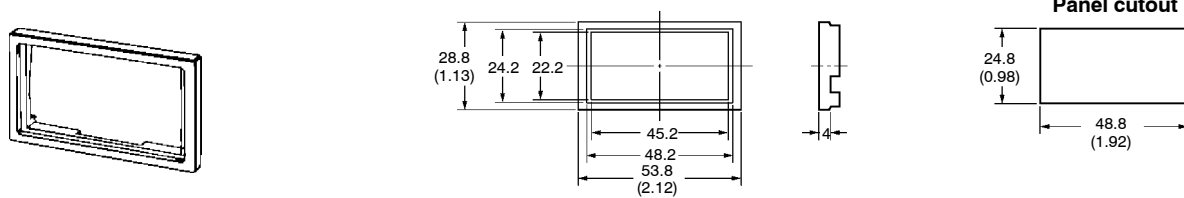

Y92S-37 Wire-Wrap Terminal (Set of Two Terminals)

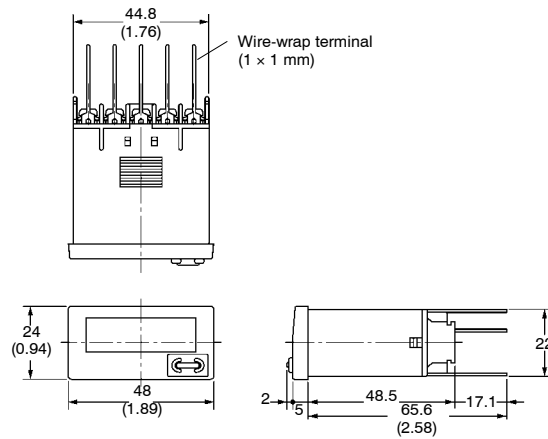
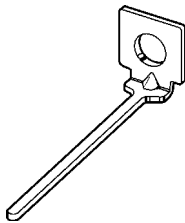

The wire-wrap terminals have a cross sectional dimension of 1x1 mm. Select one of three gauges of wire from the table at right. Also listed in the table is the appropriate wiring hardware.

Wire	Bit	Sleeve	Wrapped state
AWG22	2-A	2-B	Normal
AWG24	1-A	1-B	Normal
AWG26	1-B	1-B	Normal

■ Y92S-36 REPLACEMENT (LITHIUM) BATTERY (3 V)

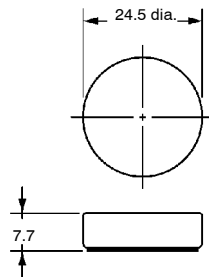

Precautions

⚠ WARNING

This product has a built-in lithium battery. Do not short-circuit the + and - terminals, charge, disassemble, deform, or expose the battery to fire. The battery may explode (break), catch fire, or cause liquid leakage.

⚠ Caution

Do not use any battery other than the specified one (Y92S-36). Using another battery may cause liquid leakage or breakage, resulting in malfunction or injury.

⚠ Caution

If a voltage other than the rated one is applied, internal elements may be damaged.

Do not use the Counter in the following places:

- Locations subject to direct sunlight.
- Locations subject to corrosive gases.
- Locations subject to dust.

■ BEFORE USE

An insulation sheet has been inserted to maintain the quality of the Totalizer in the event of a long period without use. Be sure to remove this sheet before attempting to use the product.

Remove the insulation sheet and press the Reset Key on the front panel of the Counter. (With the H7ET-N, -NV(-H), -NV1(-H), models, "0" or "0.0" will be displayed after 1 s.)

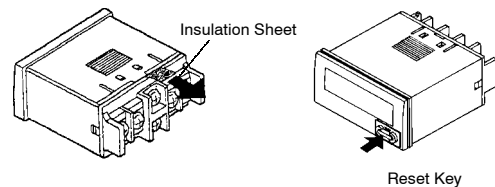

Switch settings on the Counter must be performed before mounting it to a control panel.

- Do not use the Counter in locations subject to:
- Severe changes in temperature.
 - Condensation as the result of high temperatures.

■ MOUNTING PRECAUTIONS FOR PANEL-MOUNTING

Although the operating section is watertight (conforming to NEMA 4, IP66), a rubber gasket is provided to avoid water leakage through the gap between the Counter and panel cutout. Unless this rubber gasket is tightly squeezed on, water may permeate inside the panel. For this reason, be sure to tighten the screws for fixing the panel-mounting bracket.

Screw for the Panel-Mounting Bracket

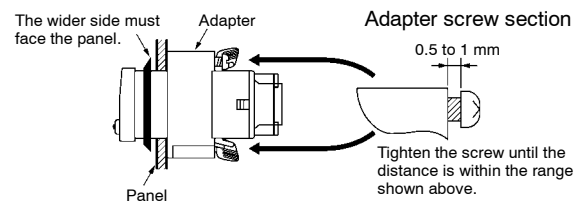

■ RESET INPUT AND COUNT INPUT

The H7ET operates using a Battery. If the H7ET is connected to a device that has +V and OUT terminals that are connected with a diode as shown in the circuit diagram, the circuit indicated by the arrow 1 or 2 will be formed when the device is turned OFF. As a result, the H7ET may be reset or count by one. Such devices should not be connected to the H7ER.

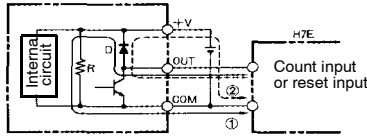

If an excessive voltage is applied to the count or reset input terminals, the internal elements may be damaged.

Ensure that the following voltages are not exceeded:

- PNP/NPN universal voltage input model: 30 VDC
- AC/DC voltage input model:
 - At count input: 240 VAC (peak voltage: 338V)
240 VDC
 - At reset input: 3 VDC (no-voltage input)
 - No-voltage input model: 3 VDC

Do not remove the outer case when voltage is being applied to the power supply terminals or to the input terminals.

The input for the H7E□-NFV□ is a high-impedance circuit so influence from an induced voltage may result in malfunction. When the input signal wiring is longer than 10 m (stray capacitance of 120 pF/m, at room temperature), a CR filter or a bleeder resistor should be connected.

■ COUNT INPUT OR RESET INPUT TO MORE THAN ONE H7ET COUNTER AT A TIME

PNP/NPN Universal DC Voltage Input

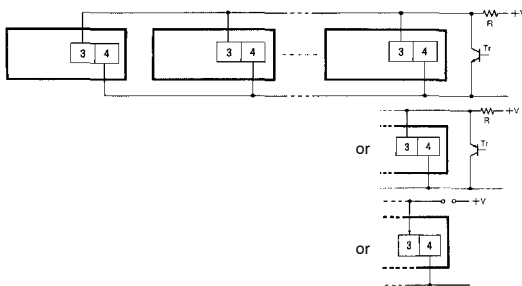

Note: H (Reset ON) level must be 4.5 V minimum.

$$H = \frac{4.7 (k\Omega)/N + V}{4.7 (k\Omega)/N + R}$$

No-voltage Input

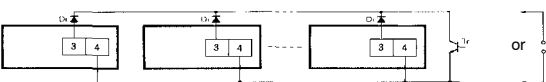

- Note:
1. The leakage current of the transistor used for input must be less than 1 μA.
 2. The forward voltage of the diode must be as low as possible (i.e., 0.1 V maximum with an I_F of 20 μA) so the voltage between terminals 3 and 4 will be 0.5 V when the reset input is ON.

■ INPUT AND POWER SUPPLY

Do not apply voltage on the Counter if the Counter is a model that operates with no-voltage input, or the internal circuit of the Counter may be damaged.

Do not connect any single input signal in parallel to Counter models operating with no-voltage input and those operating with voltage input, to avoid malfunction.

When connecting a sensor to the Counter that operates with no-voltage input, make sure that the sensor has open collector output.

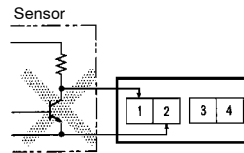

The operation of the Counter may be affected if the line voltage of the power supply exceeds 500 pF (about 10 m, with parallel wires of 2 x 2 mm). Keep all wires as short as possible. When using shielded wire, stray capacitance may occur.

When connecting an open collector input from a transistor to the Counter that operates with no-voltage input, make sure that the leakage current of the transistor is 5 μA maximum.

When connecting count input from an SSR to the Counter that operates with AC/DC voltage input, use OMRON's G3TA-1A or G3TA-ID SSR. Otherwise, make sure that the leakage current of the SSR is 0.1 mA maximum or connect a bleeder resistor in parallel to the input circuit of the Counter.

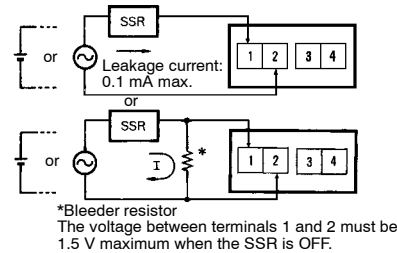

■ BACKLIGHT POWER SUPPLY

To reduce variation in the brightness of the backlight when using more than one H7ET with a backlight, use the same power supply for all the backlights.

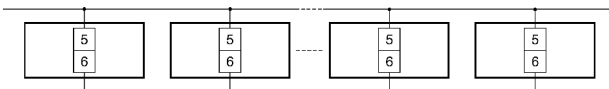

When connecting the DC power supply for the backlights, be sure to connect the polarities correctly.

■ INPUT VERIFICATION WITH THE H7ET TIME COUNTER

The decimal point of the LCD blinks every other second while an input signal is being applied. If the decimal point is not blinking, the input signal is not being received correctly. Check the input signal connections.

UNIT LABEL FOR TIME COUNTER AND TACHOMETER

A unit label has been packed with the Counter. Use in accordance with the application.

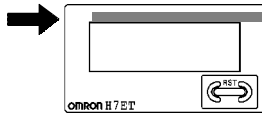

BATTERY REPLACEMENT

Remove the wiring when replacing the Battery. Do not come in contact with any item to which high voltage is being applied. Doing so may result in electric shock.

Before changing the Battery, be sure that you are not carrying any static electric charge.

Procedure for replacing the Battery (refer to the diagrams below):

1. Using the tool, pry open the lift-tab on the case. (1)
2. Pull the body out of its outer case. (2)
3. Lift the Battery up by the edge and remove it. (3)
When removing the Battery, do not come in contact with the display area or any internal parts.
4. Wipe the back of the new Battery before inserting it.
5. Ensure that the + and - terminals are correctly oriented.
6. After replacing the Battery, re-insert the body into its case. (4)
Check that the case is securely held in by the lift-tab.
7. Press the Reset Key before use (not necessary for H7ET-N,-NV,-NV1). (5)

When the internal Battery nears expiration, the display may flicker.

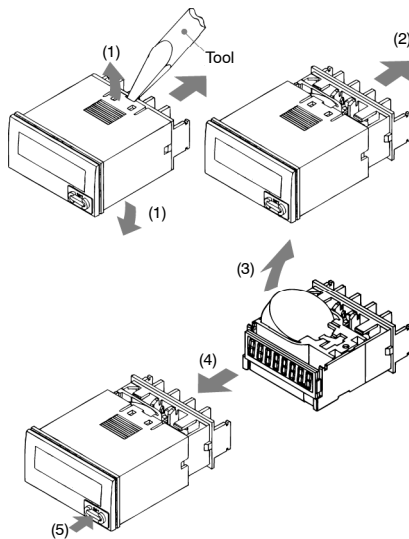

EN/IEC STANDARDS

The counter input, reset input, and backlight power supply terminals of the no-voltage input or PNP/NPN universal DC voltage input models (H7E□-N,-N1, H7E□-NV(-H),-NV1(-H)) are not isolated.

A SELV power supply conforming to Appendix H of IEC61010-1 should be used for the counter input, reset input and backlight power supply terminals. A SELV power supply is a power supply for which the input and output have double or reinforced insulation, and for which the output voltage is 30 Vrms with 42.4 V peak or 60 VDC max. (Only the H7E□-NV□-H has a backlight.)

The terminals for counter input and reset input for AC/DC multi-voltage input models have basic insulation.

Connect the reset input terminals to a device that does not have exposed current-carrying parts and has basic insulation for 240 VAC.

NOTE: DIMENSIONS SHOWN ARE IN MILLIMETERS. To convert millimeters to inches divide by 25.4.

OMRON[®]

OMRON ELECTRONICS LLC

One East Commerce Drive
Schaumburg, IL 60173

1-800-55-OMRON

OMRON ON-LINE

Global - <http://www.omron.com>
USA - <http://www.omron.com/oei>
Canada - <http://www.omron.com/oci>

OMRON CANADA, INC.

885 Milner Avenue
Scarborough, Ontario M1B 5V8

416-286-6465