

GP1A200HRS/GP1A201HRS Photointerrupter

Pachinko Ball (Pinball) Sensor with a Connector

General Description

The **GP1A200HRS/GP1A201HRS** is a pachinko ball sensor with a connector.

Features

- (1) Resists malfunction due to an optical system.
- (2) Connector output type (tamperproof)
- (3) Heat-sealed back cover (tamperproof)
- (4) Thin type (6mm): **GP1A200HRS**
For chukker gate: **GP1A201HRS**

Applications

- (1) Pachinko machines

Outline Dimensions

(Unit: mm)

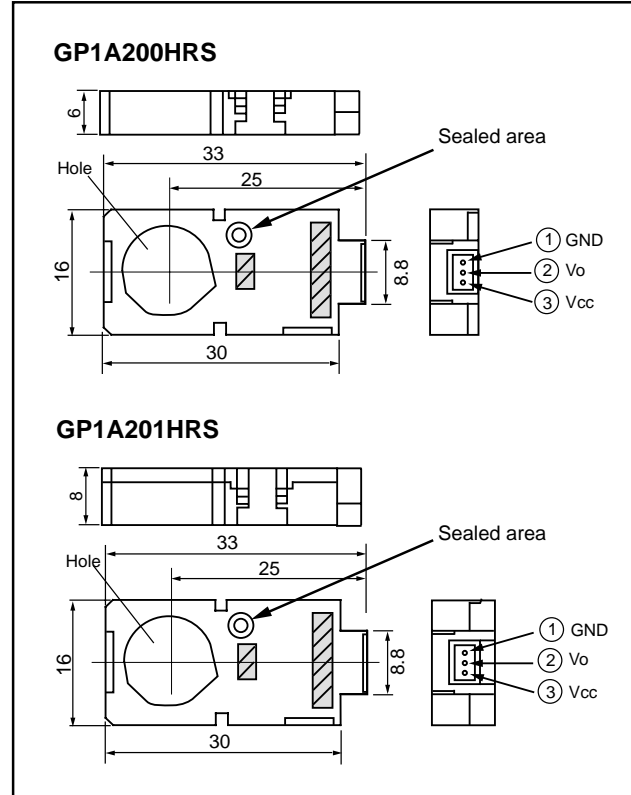

Absolute Maximum Ratings

(Ta=25°C)

Parameter	Symbol	Ratings	Unit
Supply voltage	V _{CC}	-0.5 to +16	V
Output voltage	V _{OUT}	-0.5 to +16	V
Low level output current	I _{OL}	50	mA
Operating temperature	T _{opr}	0 to +60	°C
Storage temperature	T _{stg}	-25 to +80	°C

(Notice) • In the absence of confirmation by device specification sheets, SHARP takes no responsibility for any defects that may occur in equipment using any SHARP devices shown in catalogs, data books, etc. Contact SHARP in order to obtain the latest device specification sheets before using any SHARP device.
• Specifications are subject to change without notice for improvement.

(Internet) • Data for Sharp's optoelectronic/power devices is provided on internet. (Address <http://www.sharp.co.jp/ecg/>)

SHARP

GP1A200HRS/GP1A201HRS Photointerrupter

■ Electro-optical Characteristics

(Ta=25°C)

Parameter	Symbol	Conditions	MIN.	TYP.	MAX.	Unit	
Operating supply voltage	V _{CC}	Ta=Topr	4.5	–	16	V	
Dissipation current	I _{CC}	V _{CC} =5V±10%, smoothing value	–	–	15	mA	
		V _{CC} =12V±20%, smoothing value	–	–	15	mA	
Dissipation current	I _{CCP}	V _{CC} =5V±10%, emitter value	–	–	85	mA	
		V _{CC} =12V±20%, emitter value	–	–	85	mA	
High level output voltage	V _{OH}	V _{CC} =4.5 to 16V light beam uninterrupted, no load	V _{CC} ×0.9	–	–	V	
High level output current	I _{OH}	V _{CC} =V _O =12V±20% light beam uninterrupted	–	–	50	μA	
Low level output voltage	V _{OL}	V _{CC} =5V±10%, I _{OL} =16mA light beam interrupted	–	–	0.4	V	
		V _{CC} =12V±20%, I _{OL} =16mA light beam interrupted	–	–	0.4	V	
*1 Permissible illuminance of interference level from other lights	E _{VDX}	V _{CC} =4.5 to 16V	2 000	–	–	lx	
Response characteristics	Minimum light-shielding time	T _H	V _{CC} =4.5 to 16V	1	0.4	–	ms
	Minimum light-through time	T _L		1	0.4	–	ms
Response frequency	f		–	–	500	Hz	
Pull-up resistance range	R	–	5	–	20	kΩ	

*1 Maximum illuminance value for normal operation when a CIE standard light source A is applied around the photointerrupter.

SHARP

As of May, 2000
Tec. GP990603-C