

**CONNECTOR  
DESIGNATORS**

**A-F-H-L-S  
ROTATABLE  
COUPLING**

**TYPE C OVERALL  
SHIELD TERMINATION**

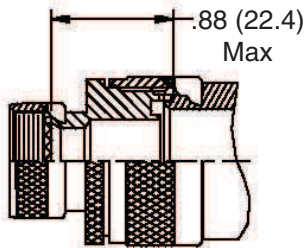
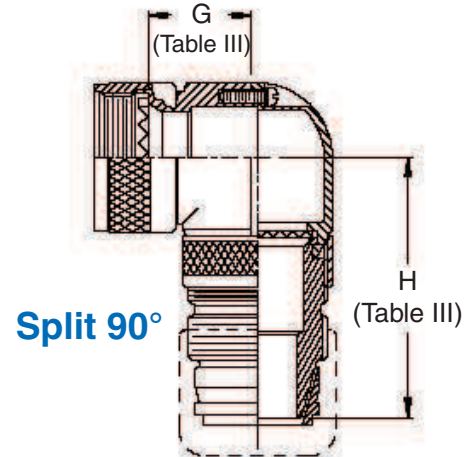
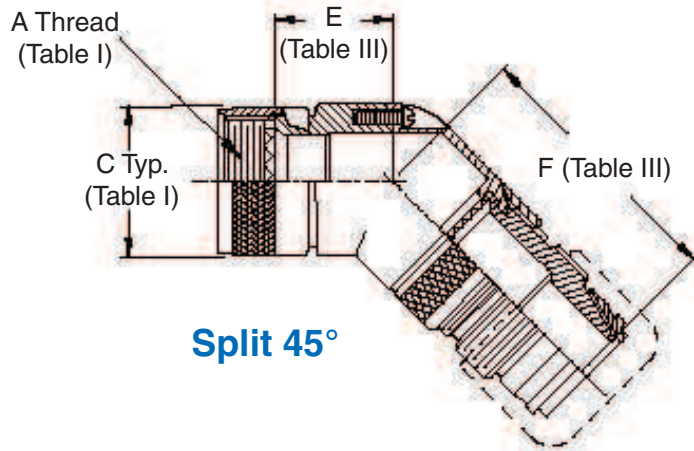
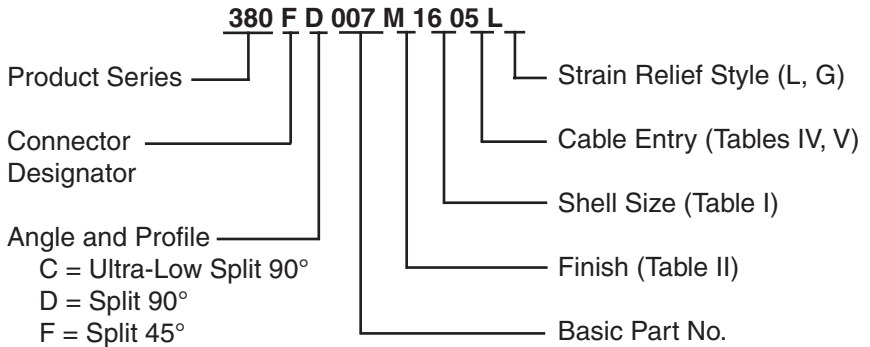

**STYLE 2**  
(See Note 1)

**STYLE L**  
Light Duty  
(Table IV)

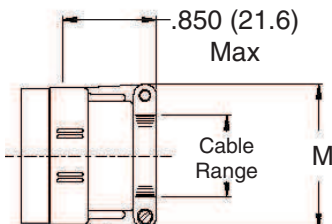

**STYLE G**  
Light Duty  
(Table V)

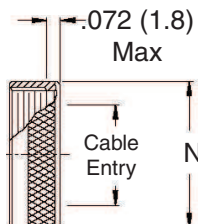

**Ultra Low-  
Profile Split  
90°**

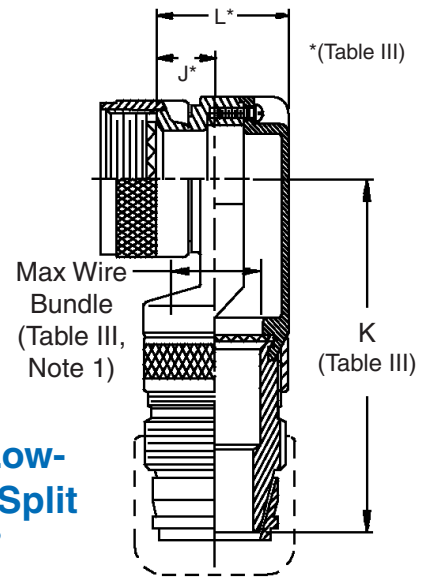

**380-007**  
**EMI/RFI Non-Environmental Backshell**  
 Light-Duty with Strain Relief  
 Type C - Rotatable Coupling - Split Shell



See inside back cover fold-out or pages  
 13 and 14 for unabridged Tables I and II.

TABLE III: DIMENSIONS								
Shell Size	E Max	F Max	G Max	H Max	J Max	K Max	L Max	Function C Max Wire Bundle
08/09	.440 (11.2)	1.782 (45.3)	.720 (18.3)	1.722 (43.7)	.340 (8.6)	2.062 (52.4)	.681 (17.3)	.250 (6.4)
10/11	.500 (12.7)	1.845 (46.9)	.720 (18.3)	1.785 (45.3)	.270 (6.9)	2.225 (56.5)	.731 (18.6)	.375 (9.5)
12/13	.560 (14.2)	1.908 (48.5)	.800 (20.3)	1.848 (46.9)	.270 (6.9)	2.218 (56.3)	.731 (18.6)	.375 (9.5)
14/15	.620 (15.7)	1.935 (49.1)	.850 (21.6)	1.875 (47.6)	.320 (8.1)	2.285 (58.0)	.831 (21.1)	.500 (12.7)
16/17	.680 (17.3)	2.040 (51.8)	.910 (23.1)	1.980 (50.3)	.420 (10.7)	2.340 (59.4)	.981 (24.9)	.625 (15.9)
18/19	.750 (19.1)	2.095 (53.2)	1.000 (25.4)	2.035 (51.7)	.640 (16.3)	2.365 (60.1)	1.181 (30.0)	.625 (15.9)
20/21	.820 (20.8)	2.160 (54.9)	1.050 (26.7)	2.100 (53.3)	.640 (16.3)	2.370 (60.2)	1.181 (30.0)	.625 (15.9)
22/23	.880 (22.4)	2.220 (56.4)	1.100 (27.9)	2.160 (54.9)	.540 (13.7)	2.520 (64.0)	1.181 (30.0)	.750 (19.1)
24/25	.940 (23.9)	2.280 (57.9)	1.200 (30.5)	2.220 (56.4)	.540 (13.7)	2.360 (59.9)	1.181 (30.0)	.750 (19.1)

TABLE II: STANDARD FINISHES	
GLENAIR	
SYMBOL	FINISH
B	Cadmium Plate, Olive Drab
M	Electroless Nickel
NF	Cadmium Plate, Olive Drab Over Electroless Nickel
See Inside Back Cover for Additional Finish Options	

TABLE IV: CABLE ENTRY			
Dash No.	M Max	Cable Range	
		Min	Max
01	.781 (19.8)	.062 (1.6)	.125 (3.2)
02	.968 (24.6)	.125 (3.2)	.250 (6.4)
03	1.046 (26.6)	.250 (6.4)	.375 (9.5)
04	1.156 (29.4)	.250 (6.4)	.500 (12.7)
05	1.218 (30.9)	.375 (9.5)	.625 (15.9)
06	1.343 (34.1)	.500 (12.7)	.750 (19.1)
07	1.468 (37.3)	.625 (15.9)	.875 (22.2)
08	1.593 (40.5)	.625 (15.9)	1.000 (25.4)
09	1.718 (43.6)	.750 (19.1)	1.125 (28.6)
10	1.843 (46.8)	.875 (22.2)	1.250 (31.8)

TABLE V: CABLE ENTRY		
Dash No.	N Max	Cable Entry Max
01	.593 (15.1)	.125 (3.2)
02	.718 (18.2)	.250 (6.4)
03	.843 (21.4)	.375 (9.5)
04	.968 (24.6)	.500 (12.7)
05	1.109 (28.2)	.625 (15.9)
06	1.218 (30.9)	.750 (19.1)
07	1.343 (34.1)	.875 (22.2)
08	1.468 (37.3)	1.000 (25.4)
09	1.593 (40.5)	1.125 (28.6)
10	1.718 (43.6)	1.250 (31.8)

1. When maximum cable entry (page 21) is exceeded, Style 2 will be supplied (not available in Function C). Dimensions E, F, G and H will not apply. Please consult factory.
2. Metric dimensions (mm) are indicated in parentheses.
3. Cable range is defined as the accommodations range for the wire bundle or cable. Dimensions shown are not intended for inspection criteria.
4. Angular function "C", low-profile split elbow, not available with "S" connector designator.