

**CONNECTOR**  
**DESIGNATORS**  
**A-F-H-L-S**  
**ROTATABLE**  
**COUPLING**

**TYPE C OVERALL**  
**SHIELD TERMINATION**

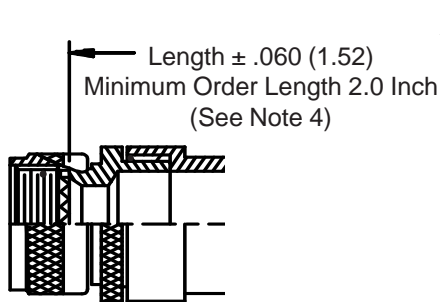

**STYLE 2**  
**(STRAIGHT**  
**See Note 1)**

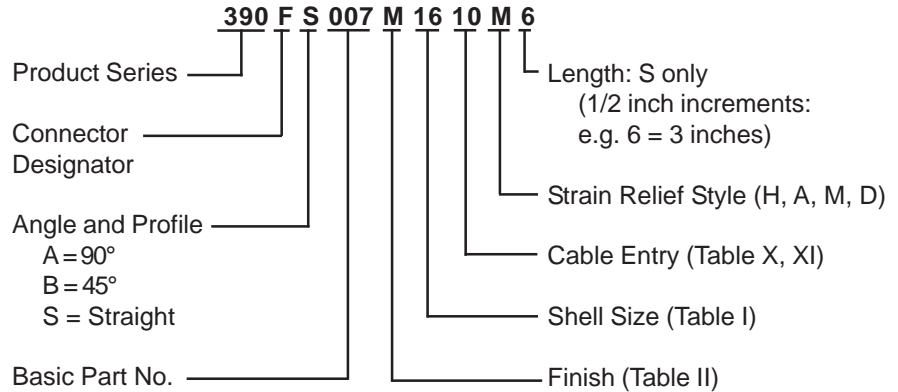
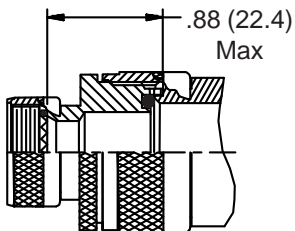

**STYLE 2**  
**(45° & 90°**  
**See Note 1)**

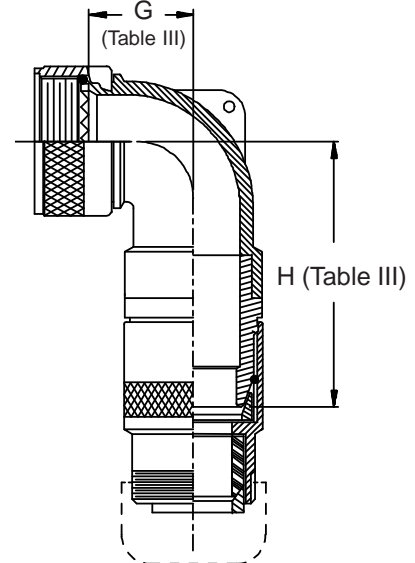
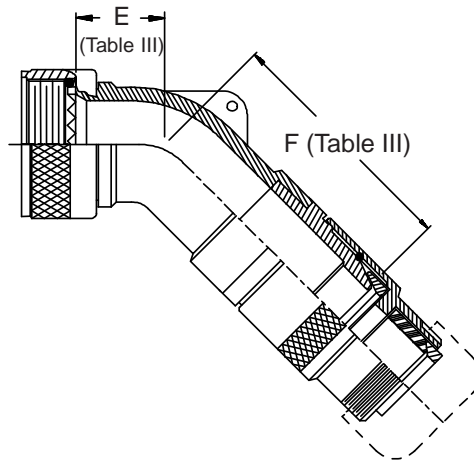
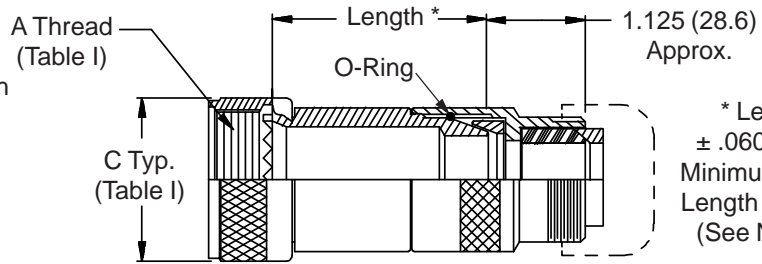

**STYLE H**  
**Heavy Duty**  
**(Table X)**

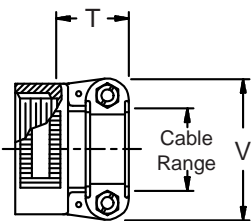

**STYLE A**  
**Medium Duty**  
**(Table XI)**

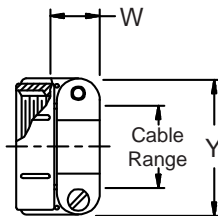

**STYLE M**  
**Medium Duty**  
**(Table XI)**

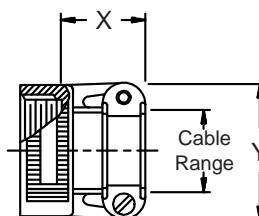

**STYLE D**  
**Medium Duty**  
**(Table XI)**

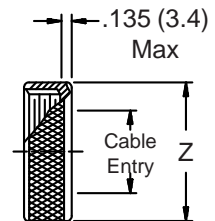

**390-007**  
**Submersible EMI/RFI Cable Sealing Backshell**  
 with Strain Relief  
**Type C - Rotatable Coupling - Low Profile**



See inside back cover fold-out or pages 13 and 14 for Tables I and II.

**TABLE III: ELBOW DIMENSIONS**

Shell Size		E		F		G		H	
Conn. Desig.	H	Max		Max		Max		Max	
A-F-L-S	H								
08	09					.500	(12.7)	2.725	(69.2)
10	11	.520	(13.2)	2.775	(70.5)	.595	(15.1)	2.845	(72.3)
12	13	.582	(14.8)	2.835	(72.0)	.610	(15.5)	2.865	(72.8)
14	15	.645	(16.4)	3.554	(90.3)	.700	(17.8)	3.564	(90.5)
16	17	.738	(18.7)	3.664	(93.1)	.885	(22.5)	3.654	(92.8)
18	19	.926	(23.5)	3.854	(97.9)	.975	(24.8)	3.824	(97.1)
20	21	.926	(23.5)	3.854	(97.9)	.975	(24.8)	3.824	(97.1)
22	23	1.020	(25.9)	4.192	(106.5)	1.125	(28.6)	4.122	(104.7)
24	25	1.020	(25.9)	4.192	(106.5)	1.125	(28.6)	4.122	(104.7)
28		1.145	(29.1)	4.225	(107.3)	1.225	(31.1)	4.275	(108.6)
32		1.207	(30.7)	4.325	(109.9)	1.575	(40.0)	4.525	(114.9)
36		1.238	(31.4)	4.465	(113.4)	1.775	(45.1)	4.575	(116.2)

**TABLE X: CABLE ENTRY**

Dash No.	T Max	V Max	Cable Range			
			Min		Max	
04	.780 (19.8)	.957 (24.3)	.125 (3.2)	.312 (7.9)		
06	.780 (19.8)	1.145 (29.1)	.250 (6.4)	.437 (11.1)		
08	.780 (19.8)	1.332 (33.8)	.387 (9.8)	.562 (14.3)		
10	.780 (19.8)	1.332 (33.8)	.350 (8.9)	.625 (15.9)		
12	.811 (20.6)	1.551 (39.4)	.500 (12.7)	.750 (19.1)		
16	.905 (23.0)	1.770 (45.0)	.625 (15.9)	.937 (23.8)		
20	1.092 (27.7)	2.113 (53.7)	.875 (22.2)	1.250 (31.8)		
24	1.124 (28.5)	2.363 (60.0)	1.000 (25.4)	1.375 (34.9)		
28	1.399 (35.5)	2.770 (70.4)	1.250 (31.8)	1.625 (41.3)		
32	1.399 (35.5)	3.020 (76.7)	1.437 (36.5)	1.875 (47.6)		

1. When maximum cable entry (page 21) is exceeded, Style 2 will be supplied. Dimensions E, F, G and H will not apply. Please consult factory.
2. Metric dimensions (mm) are indicated in parentheses.
3. Cable range is defined as the accommodations range for the wire bundle or cable. Dimensions shown are not intended for inspection criteria.
4. Consult factory for shorter lengths on straight backshells.
5. Interface O-Ring not supplied with connector designator A.

**TABLE XI: CABLE ENTRY**

Dash No.	W Max	X Max	Y Max	Z Max	Cable Range		
					Min **		Max
03*	.437 (11.1)	.760 (19.3)	.843 (21.4)	.630 (16.0)	.156 (4.0)	.250 (6.4)	
04*	.437 (11.1)	.760 (19.3)	.906 (23.0)	.755 (19.2)	.188 (4.8)	.312 (7.9)	
06*	.500 (12.7)	.760 (19.3)	1.093 (27.8)	.942 (23.9)	.281 (7.1)	.438 (11.1)	
08	.563 (14.3)	.760 (19.3)	1.187 (30.1)	1.067 (27.1)	.387 (9.8)	.562 (14.3)	
10	.563 (14.3)	.760 (19.3)	1.281 (32.5)	1.192 (30.3)	.375 (9.5)	.625 (15.9)	
12	.563 (14.3)	.760 (19.3)	1.500 (38.1)	1.380 (35.1)	.438 (11.1)	.750 (19.1)	
16	.656 (16.7)	1.073 (27.3)	1.719 (43.7)	1.535 (39.0)	.625 (15.9)	.938 (23.8)	
20	.656 (16.7)	1.323 (33.6)	2.062 (52.4)	1.848 (46.9)	.875 (22.2)	1.250 (31.8)	
24	.656 (16.7)	1.323 (33.6)	2.312 (58.7)	2.255 (57.3)	1.000 (25.4)	1.375 (34.9)	
28	1.188 (30.2)	1.572 (39.9)	2.719 (69.1)	2.505 (63.6)	1.250 (31.8)	1.625 (41.3)	
32*	1.187 (30.1)	1.572 (39.9)	2.969 (75.4)	2.755 (70.0)	1.437 (36.5)	1.875 (47.6)	
40*	1.125 (28.6)	1.572 (39.9)	3.531 (89.7)	3.255 (82.7)	1.875 (47.6)	2.375 (60.3)	

\* Not available in Style M clamp (Style A clamp supplied).      \*\* Not Applicable Style D