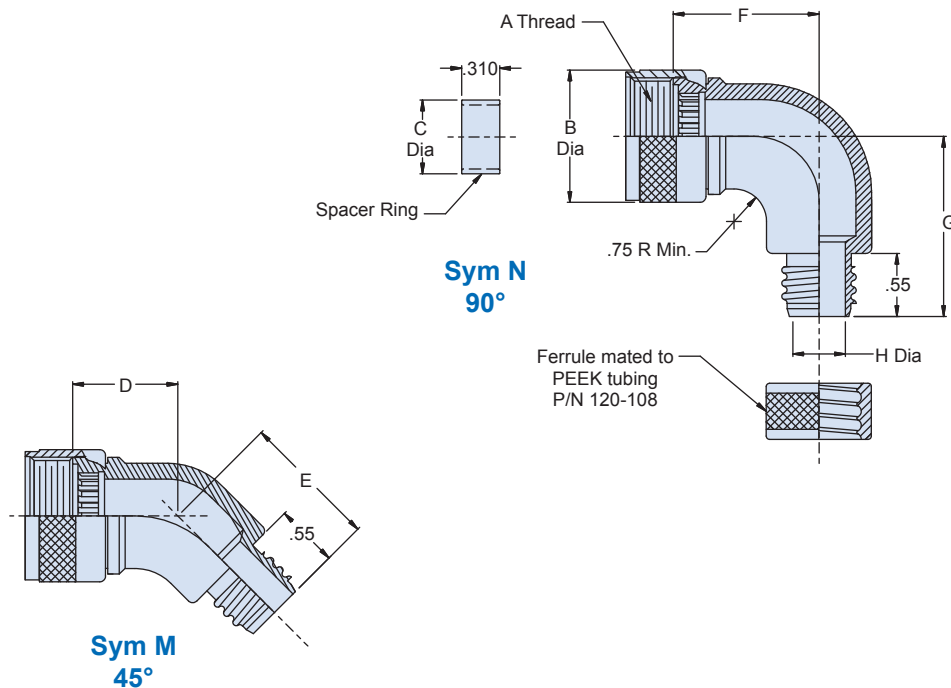

MIL-PRF-28876 fiber optic backshell, 90° and 45°, with compression nut for easy termination of PEEK convoluted tubing
How To Order
Product Series
189
Basic No.
M
021
Finish Sym (Table II)
NF
11
**Angular Function
*N or M***
**Shell Size
(Table III)**

Material/Finish

- Adapter, Coupling Nut, and Ferrule: See Table II
- Spacer Ring: Al Alloy/Gold Iridite

Notes

- Spacer Ring is packaged loose and must be installed with Connector at time of assembly to retain Terminus Insert.
- For Straight Backshell option, see Glenair drawing 189-014

189-021
90° and 45° Backshell for PEEK Convolute Tubing
to be used with MIL-PRF-28876 Fiber Optic Connectors



Table III: Shell Size/Dimensions/Conduit Size

Shell Size	Designator (Ref)	A Thread Class 2B	Ø B Max	Ø C Max	D Max	E Max	F Max	G Max	H Max	PEEK Conduit Size	
										Frac. Size	Dash No.
11	A	3/4-20 UNEF	.960 (24.4)	.410 (10.4)	0.900 (22.9)	0.950 (24.1)	1.985 (50.4)	2.035 (51.7)	.390 (9.91)	1/2	16
13	B	7/8-20 UNEF	1.085 (27.6)	.532 (13.5)	0.960 (24.4)	1.010 (25.7)	2.110 (53.6)	2.160 (54.9)	.390 (9.91)	1/2	16
15	C	1-20 UNEF	1.255 (31.9)	.710 (18.0)	1.020 (25.9)	1.070 (27.2)	2.115 (53.7)	2.165 (55.0)	.390 (9.91)	1/2	16
23	F	17/16-18 UNEF	1.695 (43.1)	1.116 (28.3)	1.270 (32.3)	1.320 (33.5)	2.485 (63.1)	2.535 (64.4)	.890 (22.6)	1	32

Table II: Material/Finish

Class	Shell Material	Finish Description
B	AL Alloy	Cadmium Plate/Olive Drab
J		Gold Iridite over Cadmium Plate over Nickel
M		Electroless Nickel
N		Cadmium Plate/Olive Drab over Nickel
NF		Cadmium/Olive Drab over Electroless Nickel (1000 Hours Salt Spray)
T		Cadmium Plate/Bright Dip over Nickel