

FW26025A1

PNP POWER DARLINGTON TRANSISTOR

- INTEGRATED ANTIPARALLEL COLLECTOR-EMITTER DIODE

APPLICATIONS

- LINEAR AND SWITCHING INDUSTRIAL EQUIPMENT

DESCRIPTION

The FW26025A1 is a silicon Epitaxial-Base PNP power transistor in monolithic Darlington configuration mounted in Jedec TO-3 metal case. It is intended for general purpose amplifier and low frequency switching applications.

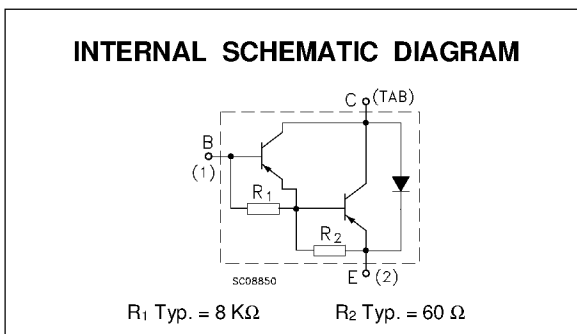
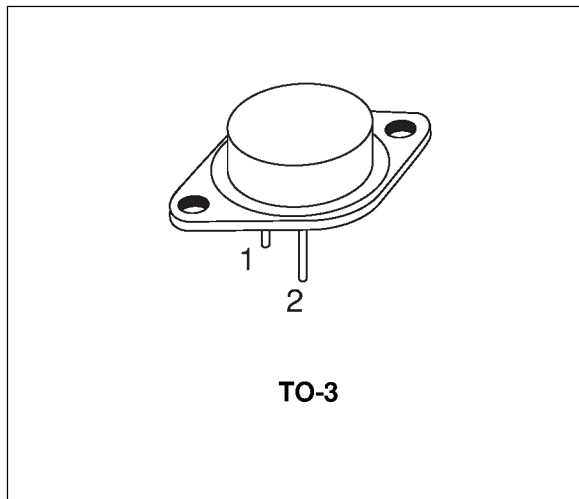

ABSOLUTE MAXIMUM RATINGS

Symbol	Parameter	Value	Unit
V _{CBO}	Collector-Base Voltage (I _E = 0)	100	V
V _{CEO}	Collector-Emitter Voltage (I _B = 0)	100	V
V _{EBO}	Emitter-Base Voltage (I _C = 0)	5	V
I _C	Collector Current	20	A
I _{CM}	Collector Peak Current	40	A
I _B	Base Current	0.5	A
P _{tot}	Total Dissipation at T _c ≤ 25 °C	160	W
T _{stg}	Storage Temperature	-65 to 200	°C
T _j	Max. Operating Junction Temperature	200	°C

THERMAL DATA

$R_{thj-case}$	Thermal Resistance Junction-case	Max	1.09	$^{\circ}C/W$
----------------	----------------------------------	-----	------	---------------

ELECTRICAL CHARACTERISTICS ($T_{case} = 25^{\circ}C$ unless otherwise specified)

Symbol	Parameter	Test Conditions	Min.	Typ.	Max.	Unit
I_{CEV}	Collector Cut-off Current ($V_{BE} = -1.5V$)	$V_{CE} = 100 V$ $V_{CE} = 100 V \quad T_C = 150^{\circ}C$			0.5 5	mA mA
I_{CEO}	Collector Cut-off Current ($I_B = 0$)	$V_{CE} = 50 V$			1	mA
I_{EBO}	Emitter Cut-off Current ($I_C = 0$)	$V_{EB} = 5 V$			2	mA
$V_{CEO(sus)*}$	Collector-Emitter Sustaining Voltage ($I_B = 0$)	$I_C = 2 mA$ $I_C = 100 mA$	90 100			V V
$V_{CE(sat)*}$	Collector-Emitter Saturation Voltage	$I_C = 10 A \quad I_B = 40 mA$ $I_C = 20 A \quad I_B = 200 mA$			2 3	V V
$V_{BE(sat)*}$	Base-Emitter Saturation Voltage	$I_C = 20 A \quad I_B = 200 mA$			4	V
V_{BE*}	Base-Emitter Voltage	$I_C = 10 A \quad V_{CE} = 3 V$			2.8	V
h_{FE*}	DC Current Gain	$I_C = 2 A \quad V_{CE} = 3 V$ $I_C = 10 A \quad V_{CE} = 3 V$ $I_C = 30 A \quad V_{CE} = 3 V$	5000 750 200		18000	
h_{fe}	Small Signal Current Gain	$I_C = 3 A \quad V_{CE} = 10 V \quad f = 1KHz$	300			
C_{CBO}	Collector Base Capacitance	$I_E = 0 \quad V_{CB} = 10 V \quad f = 100KHz$			600	pF

* Pulsed: Pulse duration = 300 μs , duty cycle 1.5 %

TO-3 MECHANICAL DATA

DIM.	mm			inch		
	MIN.	TYP.	MAX.	MIN.	TYP.	MAX.
A	11.00		13.10	0.433		0.516
B	0.97		1.15	0.038		0.045
C	1.50		1.65	0.059		0.065
D	8.32		8.92	0.327		0.351
E	19.00		20.00	0.748		0.787
G	10.70		11.10	0.421		0.437
N	16.50		17.20	0.649		0.677
P	25.00		26.00	0.984		1.023
R	4.00		4.09	0.157		0.161
U	38.50		39.30	1.515		1.547
V	30.00		30.30	1.187		1.193

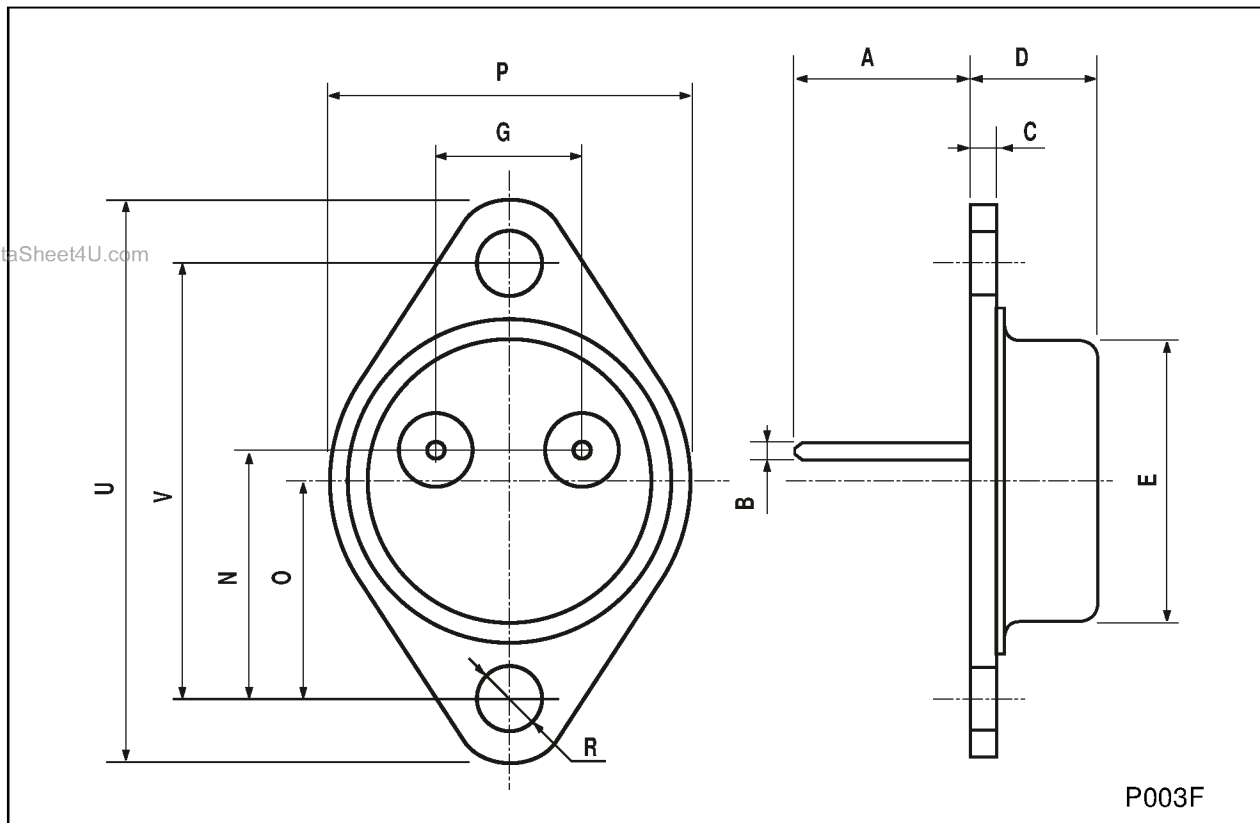

www.DataSheet4U.com

Information furnished is believed to be accurate and reliable. However, STMicroelectronics assumes no responsibility for the consequences of use of such information nor for any infringement of patents or other rights of third parties which may result from its use. No license is granted by implication or otherwise under any patent or patent rights of STMicroelectronics. Specification mentioned in this publication are subject to change without notice. This publication supersedes and replaces all information previously supplied. STMicroelectronics products are not authorized for use as critical components in life support devices or systems without express written approval of STMicroelectronics.

The ST logo is a trademark of STMicroelectronics.

All other names are the property of their respective owners.

© 2003 STMicroelectronics – All Rights reserved

STMicroelectronics GROUP OF COMPANIES

Australia - Belgium - Brazil - Canada - China - Czech Republic - Finland - France - Germany - Hong Kong - India - Israel - Italy - Japan - Malaysia - Malta - Morocco - Singapore - Spain - Sweden - Switzerland - United Kingdom - United States.

<http://www.st.com>

