

# Touch Screens

Toggles

Rockers

Pushbuttons

Illuminated PB

Programmable

Keylocks

Rotaries

Slides

Tactiles

Tilt

**Touch**

Indicators

Accessories

Supplement

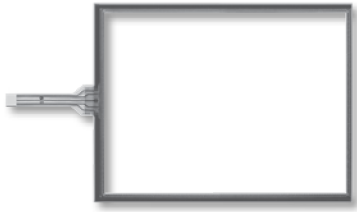

5-Wire Touchscreens .....L5

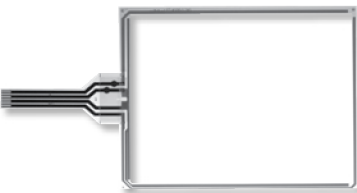

4-Wire Touchscreens .....L8

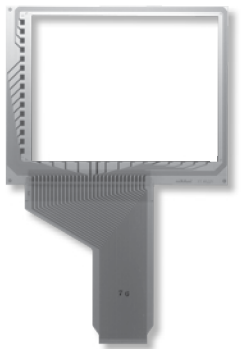

Digital Touchscreens .....L14

# Resistive Touch Screens

## 5-Wire, 4-Wire & Digital Solutions

NKK's transparent touch screens are engineered to complement the application of choice while offering superior durability and flexibility. With options in multiple sizes, and choices of input by finger, gloved finger or stylus, we maintain a consistent focus on impeccable quality and value added solutions with the diverse needs of our customers at the forefront.

Whether an application requires the 5- or 4-wire technology, the features include metal tails (analog), contact reliability with a connector, and ANR film, eliminating many of the typical visual artifacts. The film surface is non-glare and hard coated for ease of use and integrity of the surface.

Additional benefits of NKK's 5-wire touch screens include:

- Screens highly resistant to static electricity and noise pollution
- Drift-free operation despite any temperature fluctuation
- Greater touch point density translating to more precision and reduction of false actuations
- Quicker response time

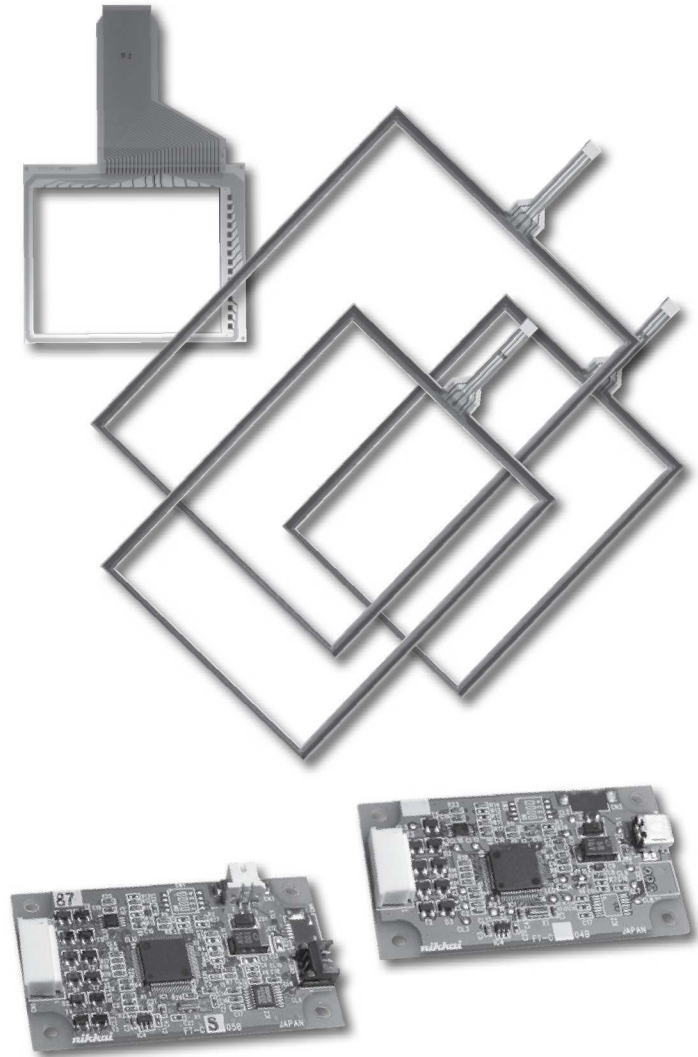

### DISTINCTIVE CHARACTERISTICS

- Wide Range of Available Sizes
- Custom Solutions a Specialty
- Digital and Analog Solutions
- Controllers Available
- Anti-Newton Ring (ANR) Technology
- Design Minimizes Visual Artifacts
- RoHS Compliant

### APPLICATIONS

- Information Kiosks
- Industrial Automation
- Banking, Exchange Management Systems
- Broadcast
- Office Automation
- Medical Equipment
- Hand-held Devices
- Hospitality and Restaurant
- Gaming

# Customization Options

Parameter	Notes & Options
Resistive Analog Touch Screen	4-Wire or 5-Wire
Integrate LCD & Touchscreen	Yes - No
5-Wire - Screen Size Diagonal Inches	Standard 10.4, 12.1, 15 (min 10.4, max 19)
4-Wire - Screen Size Diagonal Inches	Standard 5.7, 6.5, 8.4, 10.4, 12.1, 15 (min 2.5, max 19)
Data Entry Area mm x mm	Same as the dimensions of the display area of the LCD
Viewable Area mm x mm	Same as the dimensions of the bezel opening of the LCD
Perimeter Dimensions mm x mm	
Tail Type	PCB standard, FPC option
Tail Pitch	1.25mm is standard
Tail Pins	8 is standard, 4 is option
Tail Length	2 standard options: 65mm or 80mm
Tail Base Width	28.2mm is standard
Tail Location	Left side is standard, non-std options top or bottom
Tail Material	Carbon-coated silver is standard, option is copper-gold
Glass Thickness	1.1 and 1.8mm are standard (note: total thickness = glass thickness + 0.3mm)
Hardcoat Treatment	Standard
Anti-Newton Ring Treatment	Standard
Optical Transmission Factor	80% is standard
Controller	Yes - No (no = customer will supply)
Communication	USB or RS232
Operating System	Windows 7 or Windows XP

Touch

**GENERAL SPECIFICATIONS FOR 5-WIRE**

**5-Wire Resistive Analog Touch Screens**

Optical	
Light Transmission	80% standard
Film Options	Anti-glare, anti-Newton ring standard
Electrical	
Power Level	5.5V DC
X Y Resistive Value	20 ~ 80Ω
Insulation Impedance	10MΩ minimum @ 25V DC
Linearity	±2% maximum (after adjustment made by control board or device driver)
Chattering Time	10 milliseconds maximum
Mechanical	
Touch Activation Force	1.47N
Available Sizes	10.4", 12.1" and 15.0"
Durability	
Surface Hardness	2H (JIS K5600)
Expected Operational Life	Writing: 50,000 minimum operations (approximately 30mm movement with stylus)
	Tapping: 10,000,000 operations minimum (using silicon rubber)
Environmental	
Operating Temperature Range	-20°C ~ +70°C (-4°F ~ +158°F)
Storage Temperature Range	-40°C ~ +80°C (-22°F ~ +158°F)
Relative Humidity	+60°C (+140°F), humidity 90%, 240 hours

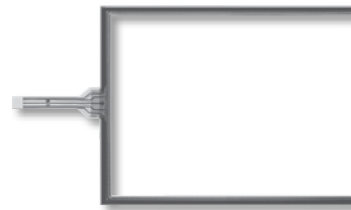

**FTAS00-104A5**

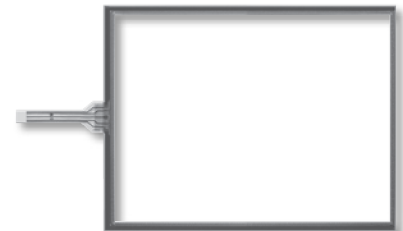

**FTAS00-121A5**

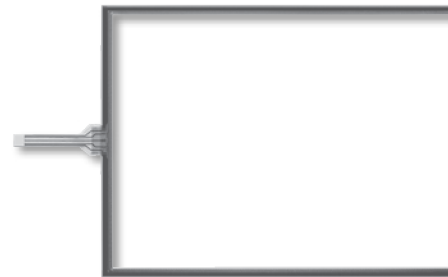

**FTAS00-150A5**

**PART NUMBERS & DESCRIPTIONS FOR 5-WIRE**

5-Wire Analog Touch Screens						
Part Number	Screen Size in Inches	Key Area Dimensions	Viewing Area Dimensions	External Dimensions	Panel Thickness	Terminal Detail 8 Pin .049" (1.25mm) Pitch
<b>FTAS00-104A5</b>	10.4	8.5" x 6.45" (215.9mm x 163.9mm)	8.66" x 6.61" (219.9mm x 167.9mm)	9.31" x 7.22" (236.5mm x 183.3mm)	.083" (2.1 mm)	Length 3.15" (80.0mm)
<b>FTAS00-121A5</b>	12.1	9.8" x 7.37" (249.0mm x 187.2mm)	9.94" x 7.50" (252.4mm x 190.6mm)	10.52" x 8.1" (267.1mm x 205.8mm)	.083" (2.1 mm)	Length 3.15" (80.0mm)
<b>FTAS00-150A5</b>	15.0	12.05" x 9.06" (306.1mm x 230.1mm)	12.19" x 9.19" (309.5mm x 233.5mm)	12.79" x 9.79" (324.8mm x 248.7mm)	.083" (2.1 mm)	Length 3.15" (80.0mm)

Note: See web site for dimensioned drawings for all 5-Wire Analog Touch Screens.

Toggles  
Rockers  
Pushbuttons  
Illuminated PB  
Programmable  
Keylocks  
Rotaries  
Slides  
Tactiles  
Tilt  
Touch  
Indicators  
Accessories  
Supplement

## GENERAL SPECIFICATIONS FOR 5-WIRE

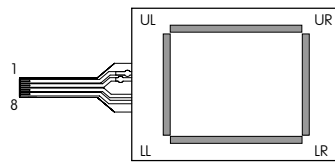
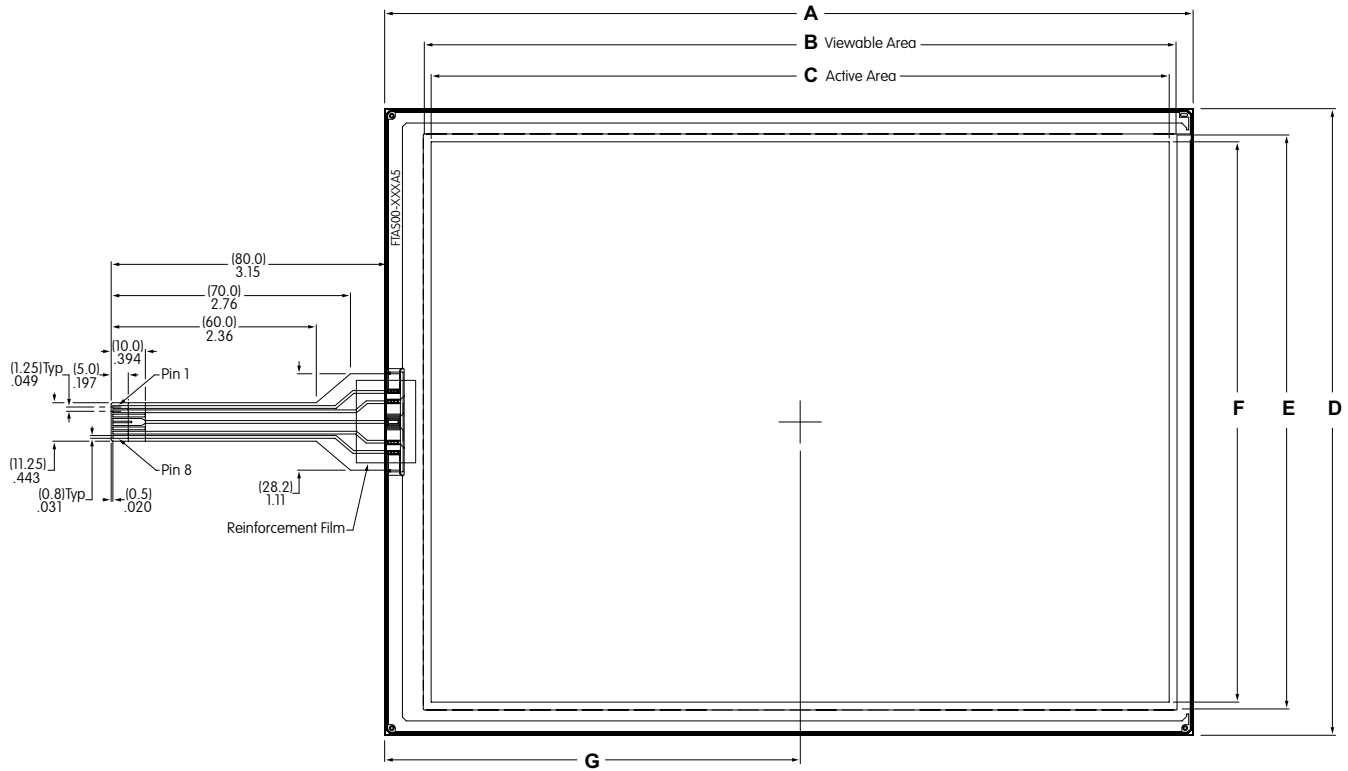

UL, LL, UR, LR: Bottom Electrode Terminal  
SENSE: Top Electrode Terminal

Pins	Signal
1	UR
2	UL
3	NC
4,5	SENSE
6	NC
7	LL
8	LR

### 5-Wire Analog Touch Screen Dimensions

Part Number	Screen Size in Inches	Dim A	Dim B Viewable Area	Dim C Active Area	Dim D	Dim E Viewable Area	Dim F Active Area	Dim G Center of Active Area
<b>FTAS00-104A5</b>	10.4	9.31 (236.5) +/-0.3	8.66 (219.9)	8.50 (215.9)	7.22 (183.3) +/-0.3	6.61 (167.9)	6.45 (163.9)	4.79 (121.55)
<b>FTAS00-121A5</b>	12.1	10.52 (267.1) +/-0.3	9.94 (252.4)	9.80 (249.0)	8.10 (205.8) +/-0.3	7.50 (190.6)	7.37 (187.2)	5.37 (136.4)
<b>FTAS00-150A5</b>	15.0	12.79 (324.8) +/-0.3	12.19 (309.5)	12.05 (306.1)	9.79 (248.7) +/-0.3	9.19 (233.5)	9.06 (230.1)	6.49 (164.95)

**5-Wire Touch Screen Controller Boards & Drivers**

**DISTINCTIVE CHARACTERISTICS**

- High Quality and Reliability
- Easy Integration Replacing Mouse Functionality
- Compatible with Control Board USB/RS232C
- Device Driver Compatible with Vista and Windows XP Operating Systems

**Controller Boards Available for RS232C**

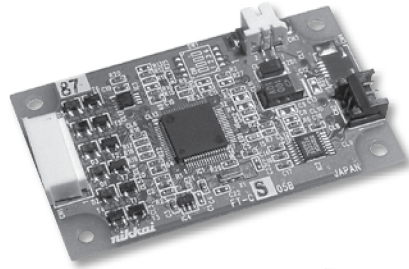

**Controller Boards Available for USB**

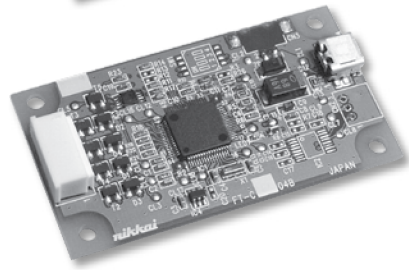

NKK offers controller boards compatible with USB or with RS232C. See web site or contact factory for specifications and technical data.

Controller Boards		
Type	Part No.	Communication Protocol
5-Wire	<b>FTCS05B</b>	RS232C
5-Wire	<b>FTCU05B</b>	USB

See web site for dimensioned drawings or technical data for any of the controller boards and drivers.

**IC & Accessories**

**DISTINCTIVE CHARACTERISTICS**

- Interface: USB and RS232C
- High Speed and Accuracy
- Built-in Calibration Function
- Data Function Removal Built In to Eliminate Noise

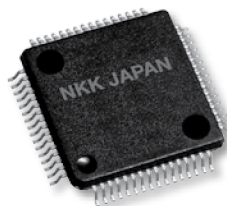

**IC FTCSU564**

The IC is for use with the 5- and 4-wire transparent touch screens, and is available for those who prefer to design their own controller boards. When the screen is touched, it recognizes the position of the touch by the level of analog voltage detected by the A/D. The A/D converter receives the value and sends a set of coordinate values as serial data or USB.

See web site or contact factory for IC specifications.

**OPTIONAL ACCESSORIES**

**AT713 Receptacle Connector**

This Receptacle Connector with code connects to RS232C communication of the controller boards.

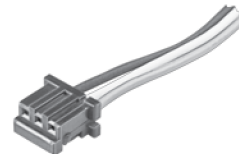

**AT714 Receptacle Connector**

AT714 is a Receptacle Connector with code to connect to power source of the control boards.



For more details and dimensioned drawings of the accessories, go to the web site or call our engineering support personnel.

## GENERAL SPECIFICATIONS FOR 4-WIRE

### 4-Wire Analog Resistive Touch Screens

Optical	
Light Transmission	Analog: 80% standard Digital: 78% standard
Film Options	Anti-glare, anti-Newton ring standard
Electrical	
Power Level	1 mA @ 5V DC (resistive load)
Insulation Impedance	10MΩ minimum @ 25V DC
Linearity	3% maximum (analog)
Chattering Time	10 milliseconds maximum
Mechanical	
Touch Activation Force	1.4N maximum
Available Sizes	5.7" ~ 15" standard
Durability	
Surface Hardness	2H (JIS K5600)
Expected Operational Life	1,000,000 operations minimum
Environmental	
Operating Temperature Range	-10°C ~ +60°C (+14°F ~ +140°F)
Storage Temperature Range	-20°C ~ +70°C (-4°F ~ +158°F)
Relative Humidity	+60°C (+140°F), humidity 90%, 240 hours

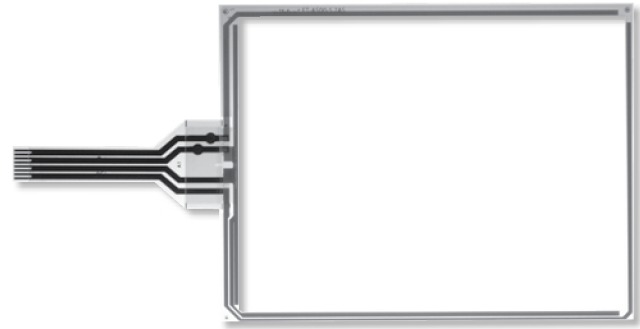

Analog  
FTAS00-57AS4

## PART NUMBERS & DESCRIPTIONS FOR 4-WIRE

4-Wire Analog Touch Screens						
Part Number	Screen Size in Inches	Key Area Dimensions	Viewing Area Dimensions	External Dimensions	Panel Thickness	* Terminal Detail 8 Pin .049" (1.25mm) Pitch
FTAS00-57AS4	5.7	4.54" x 3.40" (115.2mm x 86.4mm)	4.76" x 3.61" (121.0mm x 91.6mm)	5.16" x 3.98" (131.0mm x 101.0mm)	.055" (1.4mm)	Length 2.56" (65.0mm)
FTAS00-65AS4	6.5	5.20" x 3.90" (132.0mm x 99.0mm)	5.43" x 4.13" (138.0mm x 105.0mm)	5.91" x 4.57" (150.0mm x 116.0mm)		Length 2.56" (65.0mm)
FTAS00-84AS4	8.4	6.73" x 5.10" (170.9mm x 129.6mm)	6.95" x 5.33" (176.5mm x 135.4mm)	7.34" x 5.69" (186.5mm x 144.4mm)	.083" (2.1mm)	Length 3.15" (80.0mm)
FTAS00-104AS4	10.4	8.32" x 6.24" (211.2mm x 158.4mm)	8.47" x 6.39" (215.0mm x 162.4mm)	8.88" x 6.75" (225.6mm x 171.4mm)		Length 3.15" (80.0mm)
FTAS00-104AV4	10.4	8.35" x 6.28" (212.2mm x 159.4mm)	8.52" x 6.43" (216.4mm x 163.4mm)	8.92" x 7.21" (226.5mm x 183.0mm)		Length 3.15" (80.0mm)
FTAS00-121A4	12.1	9.72" x 7.30" (246.76mm x 185.32mm)	10.04" x 7.53" (255.0mm x 191.32mm)	10.67" x 8.07" (271.0mm x 205.0mm)		Length 3.15" (80.0mm)
FTAS00-121AS4	12.1	9.69" x 7.26" (246.0mm x 184.5mm)	9.84" x 7.42" (250.0mm x 188.5mm)	10.28" x 7.80" (261.0mm x 198.0mm)		Length 3.15" (80.0mm)
FTAS00-150A4	15.0	12.05" x 9.06" (306.1mm x 230.1mm)	12.21" x 9.25" (310.0mm x 235.0mm)	12.91" x 9.84" (328.0mm x 250.0mm)		Length 3.15" (80.0mm)

Note: Input methods are finger or stylus.

\* 4 pin available with 1.0mm or 1.25mm pitch. Contact factory for details.



**4-Wire with Horizontal Tail**

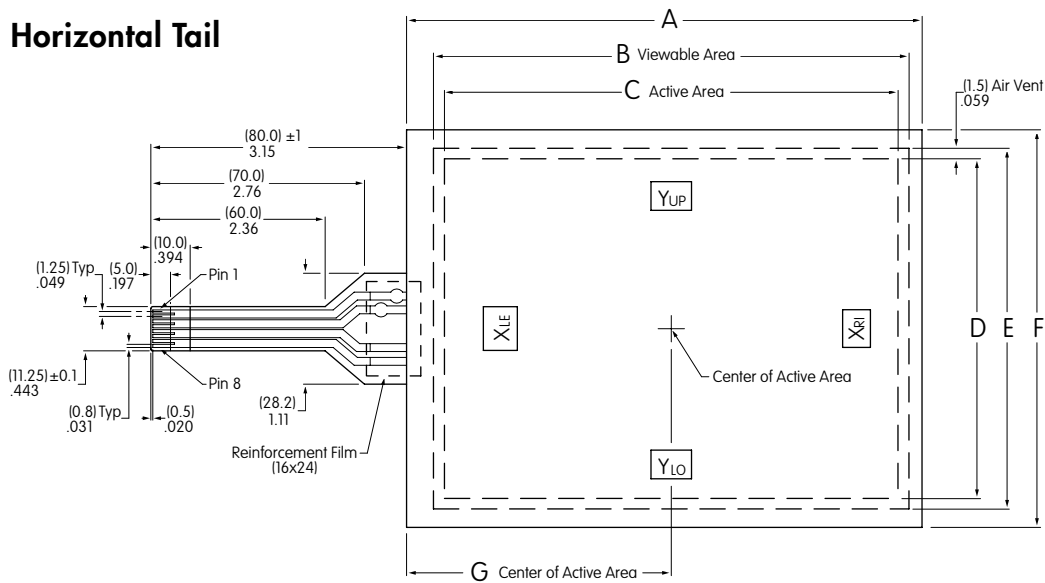

Tail Dimensions for FTAS00-57AS4 FTAS00-65AS4

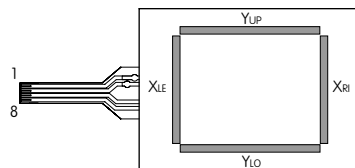
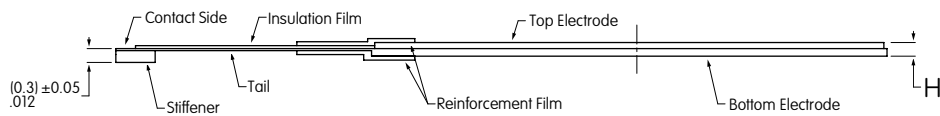
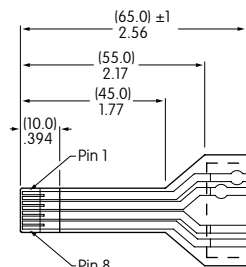

XLE, XRI: Top Electrode Terminal  
YUP, YLO: Bottom Electrode Terminal

Pins	Signal
1,2	Y <sub>UP</sub>
3,4	Y <sub>LO</sub>
5,6	X <sub>LE</sub>
7,8	X <sub>RI</sub>

**4-Wire Analog Touch Screen Dimensions**

Part Number	Screen Size in Inches	Dim A	Dim B Viewable Area	Dim C Active Area	Dim D	Dim E Viewable Area	Dim F Active Area	Dim G Center of Active Area	Dim H
<b>FTAS00-57AS4</b>	5.7	5.16" (131±0.3mm)	4.76" (121mm)	4.54" (115.2mm)	3.40" (86.4mm)	3.61" (91.6mm)	3.98" (101±0.3mm)	2.65" (67.25mm)	.055" (1.4mm)
<b>FTAS00-65AS4</b>	6.5	5.91" (150±0.3mm)	5.43" (138mm)	5.20" (132mm)	3.90" (99mm)	4.13" (105mm)	4.57" (116±0.3mm)	3.03" (77mm)	.055" (1.4mm)
<b>FTAS00-84AS4</b>	8.4	7.34" (186.5±0.3mm)	6.95" (176.5mm)	6.73" (170.9mm)	5.10" (129.6mm)	5.33" (135.4mm)	5.69" (144.4±0.3mm)	3.73" (94.85mm)	.083" (2.1mm)
<b>FTAS00-104AS4</b>	10.4	8.88" (225.6±0.3mm)	8.46" (215mm)	8.31" (211.2mm)	6.24" (158.4mm)	6.39" (162.4mm)	6.75" (171.4±0.3mm)	4.49" (114.1mm)	.083" (2.1mm)
<b>FTAS00-121AS4</b>	12.1	10.28" (261±0.3mm)	9.84" (250mm)	9.69" (246mm)	7.26" (184.5mm)	7.42" (188.5mm)	7.80" (198±0.3mm)	5.18" (131.6mm)	.083" (2.1mm)
<b>FTAS00-150A4</b>	15.0	12.91" (328±0.3mm)	12.20" (310mm)	12.05" (306.1mm)	9.06" (230.1mm)	9.25" (235mm)	9.84" (250±0.3mm)	6.52" (165.6mm)	.083" (2.1mm)

Toggle  
Rocker  
Pushbutton  
Illuminated PB  
Programmable  
Keylocks  
Rotaries  
Slides  
Tactiles  
Tilt  
Touch  
Indicators  
Accessories  
Supplement

## 4-Wire with Vertical Tail

FTAS00-104AV4

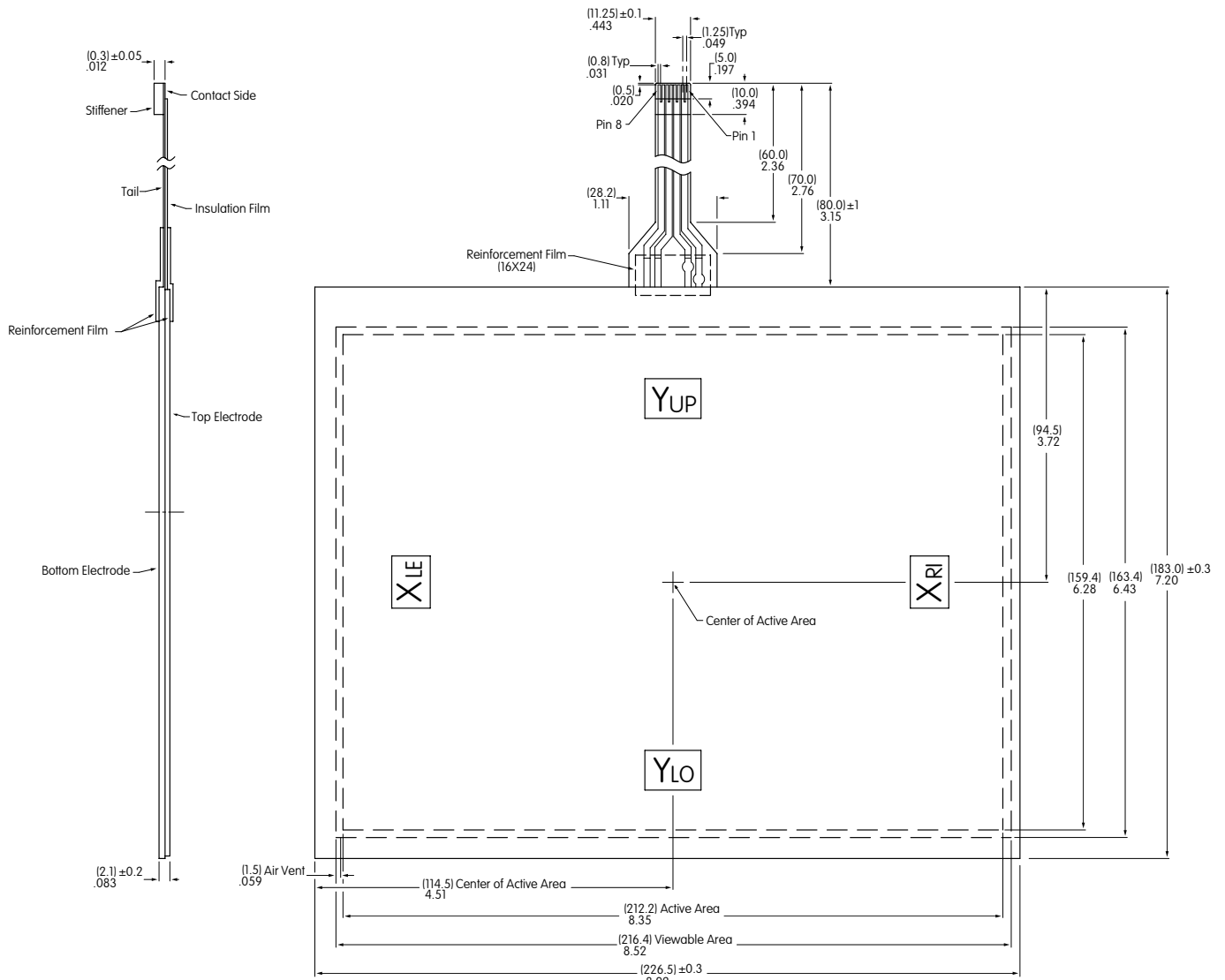

Pins	Signal
1,2	Y <sub>UP</sub>
3,4	Y <sub>LO</sub>
5,6	X <sub>RI</sub>
7,8	X <sub>LE</sub>

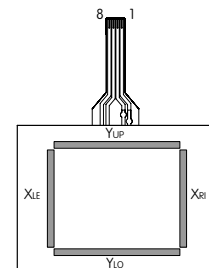

XLE, XRI: Top Electrode Terminal  
YUP, YLO: Bottom Electrode Terminal

Toggles

Rockers

Pushbuttons

Illuminated PB

Programmable

Keylocks

Rotaries

Slides

Tactiles

Tilt

Touch

Indicators

Accessories

Supplement

**4-Wire with Horizontal Tail (Off-Center)**

**FTAS00-121A4**

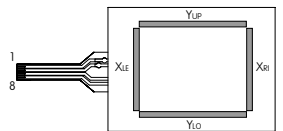
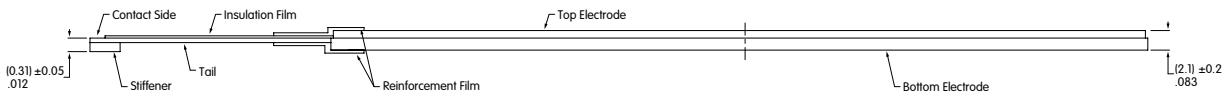
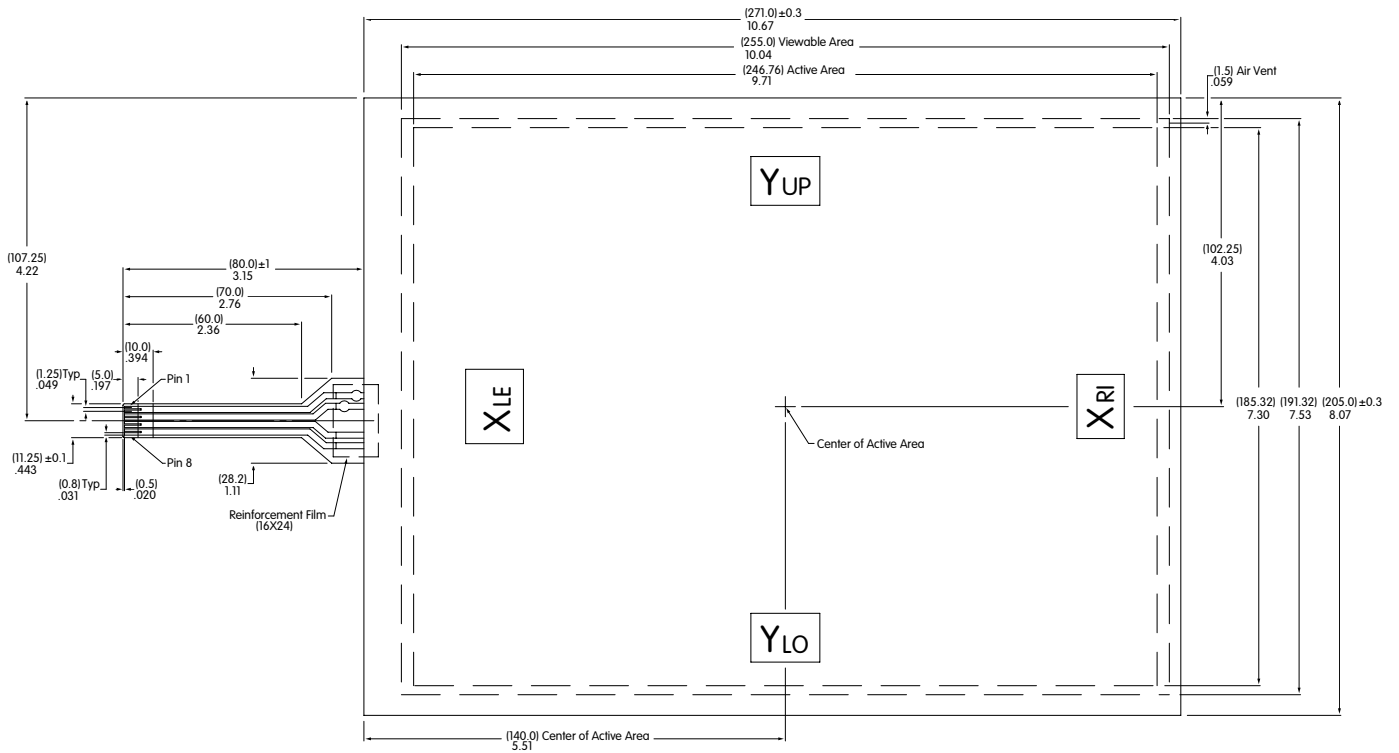

XLE, XRI: Top Electrode Terminal  
YUP, YLO: Bottom Electrode Terminal

Pins	Signal
1,2	Y <sub>UP</sub>
3,4	Y <sub>LO</sub>
5,6	X <sub>LE</sub>
7,8	X <sub>RI</sub>

Toggles

Rockers

Pushbuttons

Illuminated PB

Programmable

Keylocks

Rotaries

Slides

Tactiles

Tilt

Tilt

**L** Touch

Indicators

Accessories

Supplement

Supplement

## 4-Wire Touch Screen Controller Boards & Drivers

### DISTINCTIVE CHARACTERISTICS

- High Quality and Reliability
- Easy Integration Replacing Mouse Functionality
- Compatible with Control Board USB/RS232C
- Device Driver Compatible with Vista and Windows XP Operating Systems

**Controller Boards Available for RS232C**

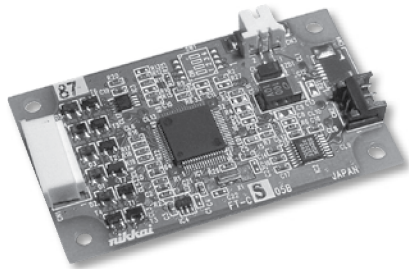

**Controller Boards Available for USB**

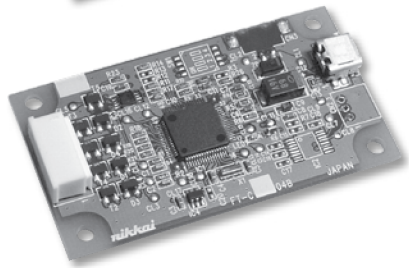

NKK offers controller boards compatible with USB or with RS232C. See web site or contact factory for specifications and technical data.

Controller Boards		
Type	Part No.	Communication Protocol
4-Wire	<b>FTCS04B</b>	RS232C
4-Wire	<b>FTCU04B</b>	USB

See web site for dimensioned drawings or technical data for any of the controller boards and drivers.

### IC & Accessories

#### DISTINCTIVE CHARACTERISTICS

- Interface: USB and RS232C
- High Speed and Accuracy
- Built-in Calibration Function
- Data Function Removal Built In to Eliminate Noise

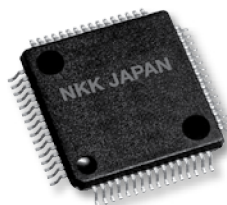

**IC FTCSU564**

The IC is for use with the 5- and 4-wire transparent touch screens, and is available for those who prefer to design their own controller boards. When the screen is touched, it recognizes the position of the touch by the level of analog voltage detected by the A/D. The A/D converter receives the value and sends a set of coordinate values as serial data or USB.

See web site or contact factory for IC specifications.

#### OPTIONAL ACCESSORIES

##### AT713 Receptacle Connector

This Receptacle Connector with code connects to RS232C communication of the controller boards. It is compatible with FTCS04A and FTCS04A2.



##### AT714 Receptacle Connector

AT714 is a Receptacle Connector with code to connect to power source of the control boards.



For more details and dimensioned drawings of the accessories, go to the web site or call our engineering support personnel.

## Storage, Handling & Installation

Below are some general precautions for the 5-wire & 4-wire touch screen devices. Please check web site for complete documentation.

### Installation (4-wire, 5-wire)

- Do not pull on the tail. Do not apply stress to the tail area.
- Avoid vibration or shock.
- The touch screen mounting should not be loose.
- Ensure there are no burrs around the edges of the case or housing that can cause false actuation. The edges of the case or housing should not enter the keying area.
- The case or housing and upper electrode should have a space of about 0.5 mm to accommodate expansion or shrinkage due to humidity variances. If a shock barrier is used do not press hard on the upper electrode area. Any shock barrier should be installed more than 0.6 mm above the screen.
- To secure the touch screen, secure the lower portion with an item such as the LCD display panel. Do not secure the upper electrode with double-sided tape or similar items to avoid stress that can damage the upper or lower electrode.
- In order to balance upper and lower pressure, an air vent may be installed. Ensure that no liquid or oil will enter into the device.

### Handling Precautions (4-wire, 5-wire)

- When opening product, take precaution with up/down and front/back directions. Glass edges are not chamfered, corners or edges can be sharp. Wear gloves when handling the product.
- Do not pick up the product by the tail or pull the tail area.
- Use gloves or finger cots to prevent fingerprints on surface.
- When handling the product, hold it outside of the viewing area.
- Avoid stacking multiple products or placing other items on the product.
- Remove protective film after installation is completed.

### Operating Precautions (4-wire, 5-wire)

- Only operate with fingers or a touch screen stylus.
- Do not press hard with pen or similar objects between viewing area and key area.

### Design Precautions (4-wire, 5-wire)

- With analog type, resistive value change can dislocate the input area. Input area can be calibrated with software.
- When installing on top of a LCD, noise from the display device can create misoperation. To avoid noise, implement actions such as grounding the display device frame.
- Do not create software for simultaneous touch points as analog type will read the center point between two touch points.
- When used to draw a line, analog type will have a break at dot spacer. Compensate for this with software.

### Other Precautions (4-wire, 5-wire)

- Clean with a soft cloth and ethanol. Do not use any cleaning agents other than ethanol.
- Store product in original package and store at the temperature and humidity range specified.
- Do not store in an environment with acids or other corrosive gases or dew.
- Not suited for use in critical control systems such as nuclear power, aerospace, medical or transportation equipment, without proper failsafe design consideration.

### Handling Precautions (5-wire)

- NKK warranties the 5-wire touch panel when it is used with the NKK control board and driver. Do not use third party control boards.
- 5-wire devices can misalign cathode position or touch position even after calibration. See web site for details.
- Create a larger input area. If you have the input button at the edge of a screen, it might not operate properly.
- Complete 9 point calibration with NKK driver. If more precision is desired, 25 point calibration is recommended.

### Handling of Controller Board (5-wire)

- Warranty for one year after delivery. We do not warranty the controller board unless used with NKK touch panel.
- Use arc prevention to protect device from static electricity.
- Power source should be activated after host and touch panel are connected.
- When inserting connector CN1 and touch panel tail, be sure the slider of connector CN1 is pulled. Do not pull more than 10 times.
- Do not alter the product.
- Do not use any commands other than the ones specified in specifications.
- Place the product away from noise source (such as inverter from LCD operation) since tail can be affected by noise.
- If device driver (USB) does not work after installation, reboot the host computer while connected to the controller board.
- This product does not support suspended mode (USB).
- Protocol of USB transmission is one frame per one transaction.
- Contact factory if not using protocol above.

Toggle

Rockers

Pushbuttons

Illuminated PB

Programmable

Keylocks

Rotaries

Slides

Tactiles

Tilt

Touch

Indicators

Accessories

Supplement

## Digital Touch Screen

Part Number	Screen Size in Inches	Key Area Dimensions	Viewing Area Dimensions	External Dimensions	Panel Thickness	Terminal Detail 30 Pin .039" (1.0mm) Pitch
<b>FTAS225-57AN</b>	5.7	4.54" x 3.39" (115.2mm x 86.04mm)	4.80" x 3.62" (122.0mm x 92.0mm)	5.51" x 4.45" (140.0mm x 113.0mm)	.083" (2.1mm)	Length 3.94" (100.0mm)

Notes: Input method is finger. Number of keys for Digital Touch Screen: 15 x 15. See web site for dimensioned drawings for the Digital Touch Screen.

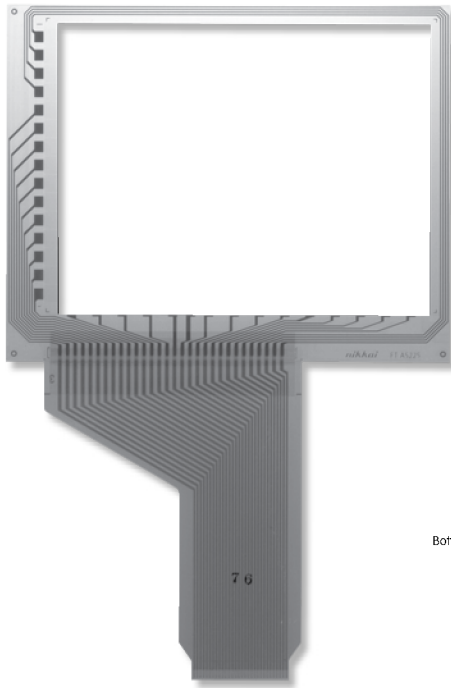

**Digital FTAS225-57AN**

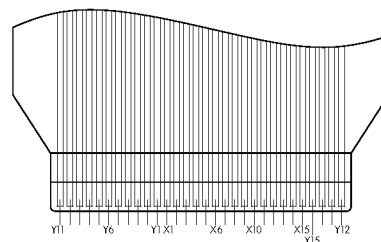
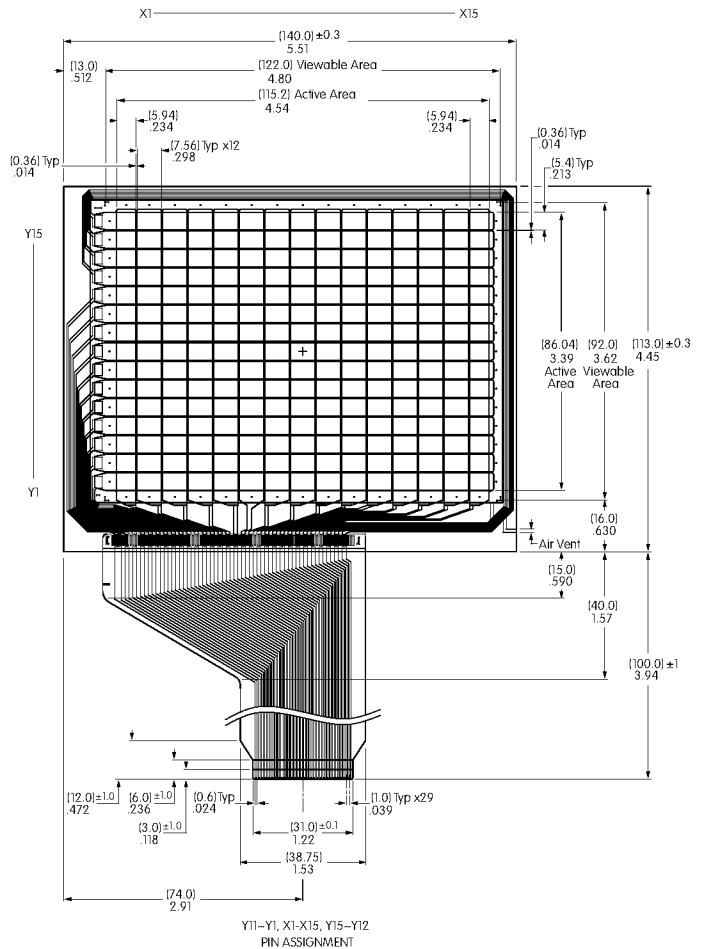
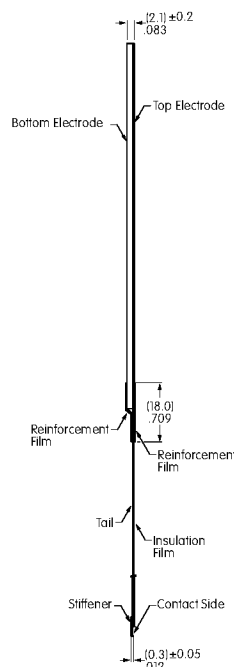

Y11-Y1, X1-X15, Y15-Y12  
PIN ASSIGNMENT