



Frontier Electronics Corp.

667 E. COCHRAN STREET, SIMI VALLEY, CA 93065

TEL: (805) 522-9998 FAX: (805) 522-9989

E-mail: frontiersales@frontierusa.com

Web: <http://www.frontierusa.com>

1A FAST RECOVERY PLASTIC RECTIFIER

1N4933-LFR THRU 1N4937-LFR

FEATURES

- LOW COST
- PLASTIC PACKAGE HAS UNDERWRITERS LABORATORY FLAMMABILITY CLASSIFICATION 94V-0
- 1 AMPERE OPERATION AT TA=55°C WITH NO THERMAL RUNAWAY
- FAST SWITCHING FOR HIGH EFFICIENCY
- EXCEEDS ENVIRONMENTAL STANDARDS OF MIL-STD-19500
- HIGH TEMPERATURE SOLDERING GUARANTEED: 250°C / 10S/0.375" (9.5mm) LEAD LENGTH / 5 LBS (2.3KG) TENSION
- ROHS

MECHANICAL DATA

- CASE: JEDEC DO-41, MOLDED CASE, DIMENSIONS IN INCHES AND (MILLIMETERS)
- TERMINAL: AXIAL LEADS, SOLDERABLE PER MIL-STD-202, METHOD 208
- POLARITY: COLOR BAND DENOTES CATHODE
- MOUNTING POSITION: ANY
- WEIGHT: 0.34 GRAMS

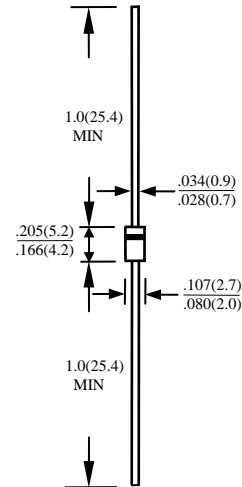

MAXIMUM RATINGS AND ELECTRICAL CHARACTERISTICS RATINGS AT 25°C AMBIENT TEMPERATURE UNLESS OTHERWISE SPECIFIED SINGLE PHASE, HALF WAVE, 60 HZ, RESISTIVE OR INDUCTIVE LOAD. FOR CAPACITIVE LOAD, DERATE CURRENT BY 20%

RATINGS	SYMBOL	1N4933-LF R	1N4934-LF R	1N4935-LF R	1N4936-LF R	1N4937-LF R	UNITS
MAXIMUM RECURRENT PEAK REVERSE VOLTAGE	V _{RRM}	50	100	200	400	600	V
MAXIMUM RMS VOLTAGE	V _{RMS}	35	70	140	280	420	V
MAXIMUM DC BLOCKING VOLTAGE	V _{DC}	50	100	200	400	600	V
MAXIMUM AVERAGE FORWARD RECTIFIED CURRENT 0.375"(9.5mm) LEAD LENGTH AT TA=55°C	I _O	1.0					A
PEAK FORWARD SURGE CURRENT, 8.3ms SINGLE HALF SINE-WAVE SUPERIMPOSED ON RATED LOAD	I _{FSM}	30					A
TYPICAL JUNCTION CAPACITANCE (NOTE 1)	C _J	15					PF
TYPICAL THERMAL RESISTANCE (NOTE 2)	R _{θja}	50					°C/W
STORAGE TEMPERATURE RANGE	T _{STG}	- 55 TO + 150					°C
OPERATING TEMPERATURE RANGE	T _{OP}	- 55 TO + 150					°C

ELECTRICAL CHARACTERISTICS (A_T T_A =25°C UNLESS OTHERWISE NOTED)

CHARACTERISTICS	SYMBOL	1N4933-LF R	1N4934-LF R	1N4935-LF R	1N4936-LF R	1N4937-LF R	UNITS
MAXIMUM FORWARD VOLTAGE AT I _O DC	V _F	1.2					V
MAXIMUM REVERSE CURRENT AT 25°C	I _R	5					μA
MAXIMUM REVERSE CURRENT AT 100°C	I _R	50					μA
MAXIMUM REVERSE RECOVERY TIME (NOTE 2)	T _{RR}	120					nS

- NOTE: 1. MEASURED AT 1 MHZ AND APPLIED REVERSE VOLTAGE OF 4.0 VOLTS
 2. BOTH LEADS ATTACHED TO HEAT SINK 20x20x1t(mm) COPPER PLATE AT LEAD LENGTH 5mm
 3. REVERSE RECOVERY TEST CONDITIONS: I_F=0.5A, I_R=1.0A, I_{RR}=0.25A

RATINGS AND CHARACTERISTIC CURVE 1N4933-LFR THRU 1N4937-LFR

FIG. 1-TEST CIRCUIT DIAGRAM AND REVERSE RECOVERY TIME CHARACTERISTIC

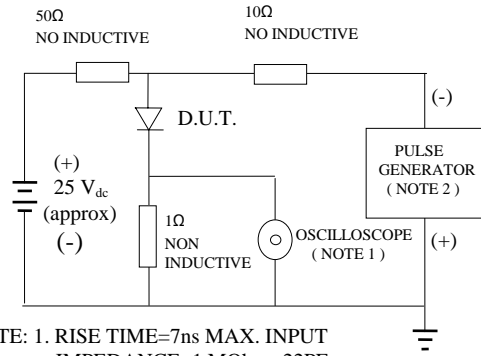

NOTE: 1. RISE TIME=7ns MAX. INPUT IMPEDANCE=1 MOhms 22PF
 2. RISE TIME=10ns MAX. SOURCE IMPEDANCE=50 OHMS

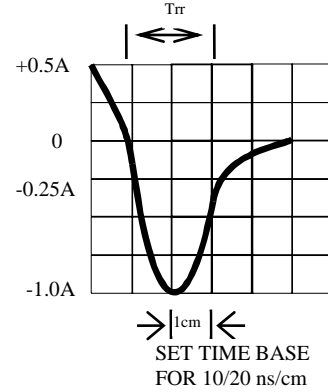

Fig. 2-MAXIMUM CURRENT DERATING CURVE

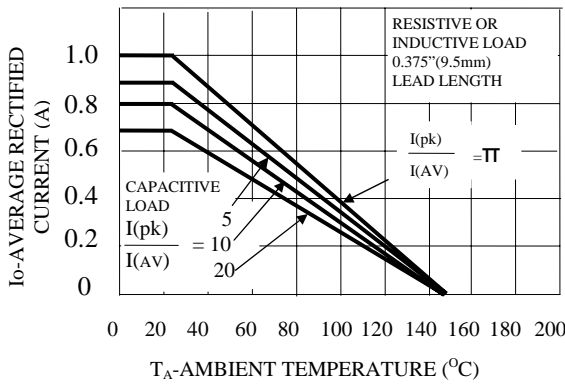

Fig. 5-MAXIMUM FORWARD SURGE CURRENT NUMBER OF CYCLES

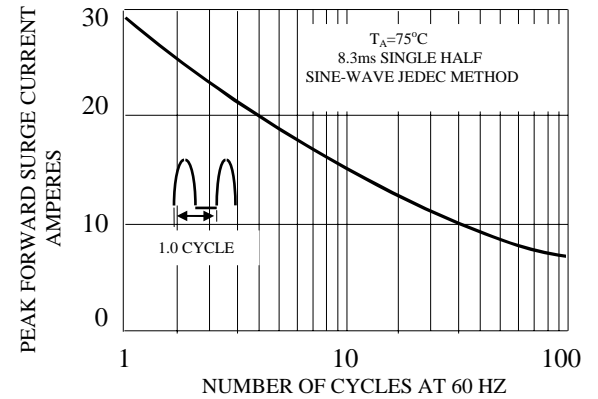

FIG. 3-TYPICAL JUNCTION CAPACITANCE

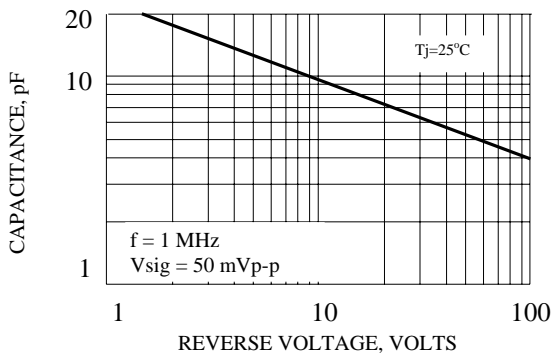

FIG. 6-TYPICAL INSTANTANEOUS FORWARD CHARACTERISTICS

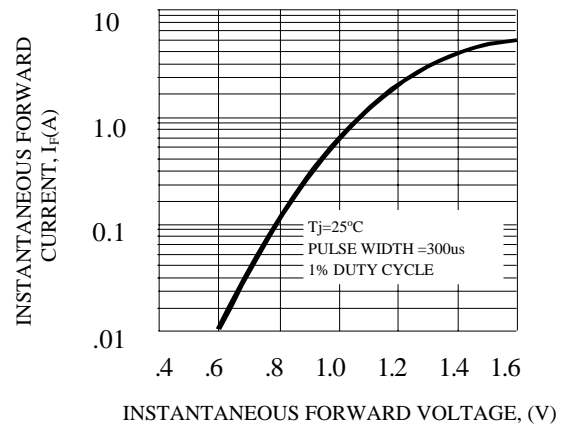

FIG. 4-TYPICAL REVERSE CHARACTERISTICS

