

CONNECTOR ASSY

<P/N composition> <P/N構成>
10051922-24 1 LF

- Lead free 鉛フリー
- Contact point plating variation (1: Au plating) 接点鍍膜のバリエーション (1: ゴールド)
- The number of contacts 極数
- Series name シリーズ名

PARTS TABLE 部品表

No.	Part name 部品名	Material 材質	Finish めっき	Note 備考
①	Housing ハウジング	Enter glass fiber LCP resin ガラス繊維入り LCP 樹脂	---	色: 黒色, ULS4V-0 Color: Black, ULS4V-0
②	Actuator アクチュエーター	Enter glass fiber SPPA resin ガラス繊維入り SPPA樹脂	---	色: 黒, ULS4V-0 Color: Black, ULS4V-0
③	Contact コンタクト	Copper alloy 銅合金	Au plating (Nickel underplating) 金めっき (ニッケル下地めっき)	ニッケル下地あり With Ni dam on the contact
④	Fitting nail (right side) 挿着金具 (右側)	Copper alloy 銅合金	Tin alloy plating (Nickel underplating) スズ合金めっき (ニッケル下地めっき)	---
⑤	Fitting nail (left side) 挿着金具 (左側)	Copper alloy 銅合金	Tin alloy plating (Nickel underplating) スズ合金めっき (ニッケル下地めっき)	---

Au	14.5	15.72	17.5	1	1	30	1	1	10051922-301LF
	13.5	14.72	16.5	1	1	28	1	1	10051922-281LF
12.5	13.72	15.5	1	1	26	1	1	10051922-261LF	
11.5	12.72	14.5	1	1	24	1	1	10051922-241LF	
10.5	11.72	13.5	1	1	22	1	1	10051922-221LF	
9.5	10.72	12.5	1	1	20	1	1	10051922-201LF	
9	10.22	12	1	1	19	1	1	10051922-191LF	
8.5	9.72	11.5	1	1	18	1	1	10051922-181LF	
7.5	8.72	10.5	1	1	16	1	1	10051922-161LF	
7	8.22	10	1	1	15	1	1	10051922-151LF	
6.5	7.72	9.5	1	1	14	1	1	10051922-141LF	
5.5	6.72	8.5	1	1	12	1	1	10051922-121LF	
5	6.22	8	1	1	11	1	1	10051922-111LF	
4.5	5.72	7.5	1	1	10	1	1	10051922-101LF	
3.5	4.72	6.5	1	1	8	1	1	10051922-081LF	

CONTACT PLATING	DIM "C"	DIM "B"	DIM "A"	⑤ FITTING NAIL(L) QTY	④ FITTING NAIL(R) QTY	③ CONTACT QTY	② ACTUATOR QTY	① HOUSING QTY	PRODUCT NO.
mat'l. code	---			surface	ISO 1302	tolerance	ISO 406	projection	product family
tr	description	ecn no	dr	date	tolerances unless otherwise specified		ISO 1101	mm	59GF FLEX 0.5
A	RELEASED	J05-0356	N.S	6/20/05	angles	linear	0.XX ±0.3	→	ASSEMBLY
					±2°	0.XXX ±0.3	0.XXX ±0.3	scale 10:1	0.5mm PITCH CONNECTOR FOR FPC VLL Series
E	REVISED	J08-0283	N.S	2008-7-1	dr	N.SASAME	2010-6-23		sheet 2 of 5 size
F	REVISED	J08-0178	N.S	2008-5-7	enrg	N.SASAME	2010-6-23		10051922
G	ADDED/P	J10-0142	N.S	2010-6-4	chr	N.SASAME	2010-6-23		A3
H	REVISED	J10-0171	N.S	2010-6-23	appd	N.SASAME	2010-6-23		type Product Customer Drawing
sheet index	revision sheet								Rev.

CONNECTOR ASSY
HALOGEN FREE

<P/N composition> <P/N 構成>
10051922-24 1 H LF

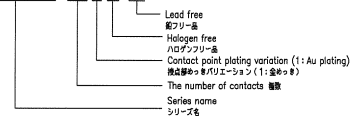

PARTS TABLE 部品表

No.	Part name	Material	Finish	Note
①	Housing ハウジング	Enter glass fiber LCP resin ガラス繊維入り LCP 樹脂	—	色: 無色, UL94V-0 Color: Natural, UL94V-0
②	Actuator アクチュエーター	Enter glass fiber LCP resin ガラス繊維入り LCP 樹脂	—	色: 無色, UL94V-0 Color: Natural, UL94V-0
③	Contact コンタクト	Copper alloy 銅合金	Au plating (Nickel underplating) 金めっき (ニッケル下地めっき)	ニッケル下地 With Ni dam on the contact
④	Fitting nail (Right side) 挿込金 (右側)	Copper alloy 銅合金	Tin alloy plating (Nickel underplating) スズ合金めっき (ニッケル下地めっき)	—
⑤	Fitting nail (Left side) 挿込金 (左側)	Copper alloy 銅合金	Tin alloy plating (Nickel underplating) スズ合金めっき (ニッケル下地めっき)	—

	14.5	15.72	17.5	1	1	30	1	1	10051922-301HLF
	13.5	14.72	16.5	1	1	28	1	1	10051922-281HLF
	12.5	13.72	15.5	1	1	26	1	1	10051922-261HLF
	11.5	12.72	14.5	1	1	24	1	1	10051922-241HLF
	10.5	11.72	13.5	1	1	22	1	1	10051922-221HLF
	9.5	10.72	12.5	1	1	20	1	1	10051922-201HLF
	9	10.22	12	1	1	19	1	1	10051922-191HLF
	8.5	9.72	11.5	1	1	18	1	1	10051922-181HLF
	7.5	8.72	10.5	1	1	16	1	1	10051922-161HLF
	7	8.22	10	1	1	15	1	1	10051922-151HLF
	6.5	7.72	9.5	1	1	14	1	1	10051922-141HLF
	5.5	6.72	8.5	1	1	12	1	1	10051922-121HLF
	5	6.22	8	1	1	11	1	1	10051922-111HLF
	4.5	5.72	7.5	1	1	10	1	1	10051922-101HLF
	3.5	4.72	6.5	1	1	8	1	1	10051922-081HLF

CONTACT PLATING	DIM "c"	DIM "b"	DIM "a"	⑤ FITTING NAIL(L) QTY	④ FITTING NAIL(R) QTY	③ CONTACT QTY	② ACTUATOR QTY	① HOUSING QTY	PRODUCT NO.	
mat'l. code	---			surface	ISO 1302	tolerance	ISO 406	projection	product family	CODE
ltr	description	ecn no	dr	date	tolerances unless otherwise specified	linear	0.XX ±0.3	mm	59GF FLEX 0.5	JP
					angles	0.XXX ±0.3	scale 10:1		ASSEMBLY	
					±2°	0.XXX ±0.3			0.5mm PITCH CONNECTOR FOR FPC	
					dr	N.SASAME 2010-6-23			VLL Series	
					enrg	N.SASAME 2010-6-23			sheet 3 of 5 size	
G	ADDEDP/N	J10-0142	N.S	2010-6-4	chr	N.SASAME 2010-6-23			10051922	A3
H	REVISED	J10-0171	N.S	2010-6-23	appd	N.SASAME 2010-6-23			type	Product Customer Drawing
sheet index	revision								Rev.	
	sheet								H	

PRODUCT NO.	DIM "A"	DIM "B"	DIM "C"	DIM "D"	DIM "E"	CONTACT PLATING	Emboss QTY.	TOOLING AVAILABLE
10051922-081OELF	16	7.5	21.5	8	--	Au	4500	YES
10051922-101OELF								YES
10051922-111OELF								YES
10051922-121OELF								YES
10051922-141OELF								YES
10051922-151OELF	24	11.5	29.5	8	--	Au	4500	YES
10051922-161OELF								YES
10051922-181OELF								YES
10051922-191OELF								YES
10051922-201OELF								YES
10051922-221OELF								YES
10051922-241OELF								YES
10051922-261OELF	32	14.2	37.5	8	28.4	Au	4500	YES
10051922-281OELF								YES
10051922-301OELF								YES

No.	Part name	Material	QTY.	Notes
①	The reel for packaging	Polyethylene	1	Color: White, Electrification prevention processing
②	Emboss tape	PET	1	Electrification prevention processing
③	Cover tape	Polyester	1	
④	Connector	See sheet 1	4500	APPLIED FOR 8mm PITCH EMBOS TAPE

EMBOSS PACKAGE

NOTE

- This article carries out the emboss tape package of the 0.5mm pitch connector for FPC.
- The shape and dimension of this article are based on JIS C 0806. (Taping of electronic parts (Surface mounted device))

注記

- 本品は 0.5mm ピッチ FPC 用コネクタをエンボステープ梱包したものである。
- 本品の形状及び寸法規定は JIS C 0806 (電子部品のテーピング (表面実装部品)) に準拠する。

<P/N composition> <P/N 構成>

10051922-16 1 0E LF

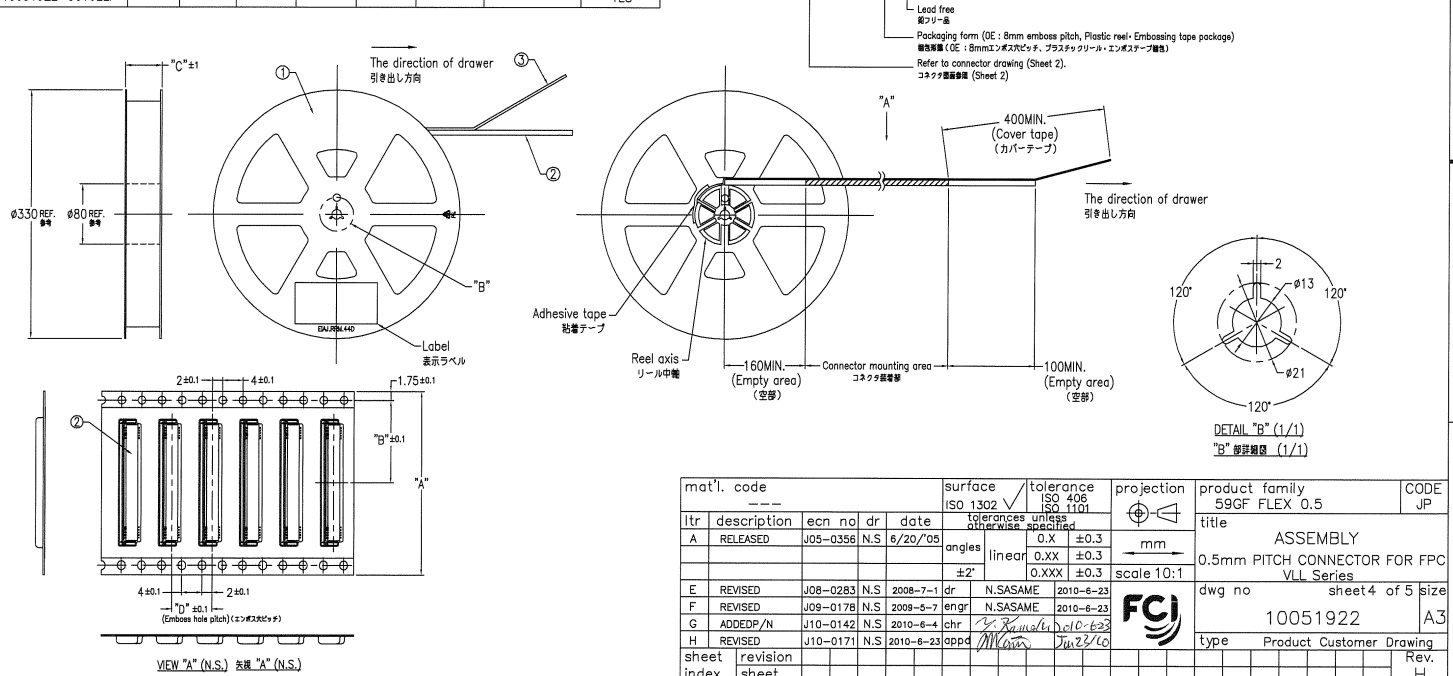

mat'l. code	surface	tolerance	projection	product family	CODE
---	ISO 1302	ISO 406	mm	59GF FLEX 0.5	JP
ISO 1101	tolerances unless otherwise specified	0.XX ± 0.3	mm	ASSEMBLY	
angles ± 2°	linear 0.XXX ± 0.3	0.XXX ± 0.3	scale 10:1	0.5mm PITCH CONNECTOR FOR FPC	
E REVISION	J08-0283	N.S	2008-7-1	dr	N.SASAME 2010-6-23
F REVISION	J08-0178	N.S	2008-5-7	enrg	N.SASAME 2010-6-23
G ADDED P/N	J10-0142	N.S	2010-6-4	chr	Y. Yamada, c10-623
H REVISION	J10-0171	N.S	2010-6-23	appd	M. Iwata, Jun 23/10
sheet index	revision sheet				

PRODUCT NO.	DIM "A"	DIM "B"	DIM "C"	DIM "D"	DIM "E"	CONTACT PLATING	Emboss QTY.	TOOLING AVAILABLE
10051922-0810EHLF	16	7.5	21.5	8	--	Au	4500	YES
10051922-1010EHLF								YES
10051922-1110EHLF								YES
10051922-1210EHLF								YES
10051922-1410EHLF								YES
10051922-1510EHLF	24	11.5	29.5	8	--	Au	4500	YES
10051922-1610EHLF								YES
10051922-1810EHLF								YES
10051922-1910EHLF								YES
10051922-2010EHLF								YES
10051922-2210EHLF	32	14.2	37.5	8	28.4	Au	4500	YES
10051922-2410EHLF								YES
10051922-2610EHLF								YES
10051922-2810EHLF								YES
10051922-3010EHLF								YES

No.	Part name	Material	QTY.	Note
①	The reel for packaging 巻取用リール	Polyethylene ポリエチレン	1	Color: White, Electrification prevention processing 色:白、帯電防止処理品
②	Emboss tape エンボステープ	PET	1	Electrification prevention processing 帯電防止処理品
③	Cover tape カバーテープ	Polyester ポリエステル	1	
④	Connector コネクタ	See sheet 1	4500	APPLIED FOR 6mm PITCH EMBOS TAPE

EMBOSS PACKAGE
HALOGEN FREE

NOTE

- This article carries out the emboss tape package of the 0.5mm pitch connector for FPC.
- The shape and dimension of this article are based on JIS C 0806.
(Taping of electronic parts (Surface mounted device))

注 記

- 本品は 0.5mm ピッチ FPC 用コネクタをエンボステープ梱包したものである。
- 本品の形状及び寸法規定は JIS C 0806 (電子部品のテーピング (表面実装部品)) に準拠する。

<P/N composition> <P/N 構成>

10051922-16 1 0E H LF

- Lead free
鉛フリー品
- Halogen free
ハロゲンフリー品
- Packaging form (IE: 6mm emboss pitch, Plastic reel-Embossing tape package)
梱包形態 (IE: 6mmピッチエンボステープ、プラスチックリール-エンボステープ梱包)
- Refer to connector drawing (Sheet 2).
コネクタ参照図表 (Sheet 2)

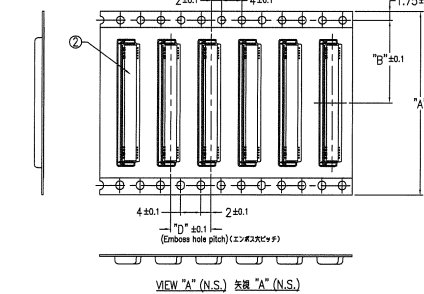
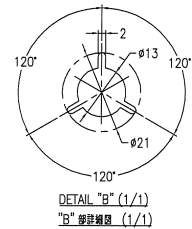
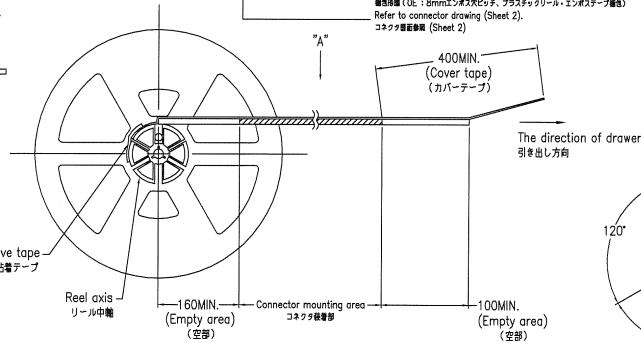
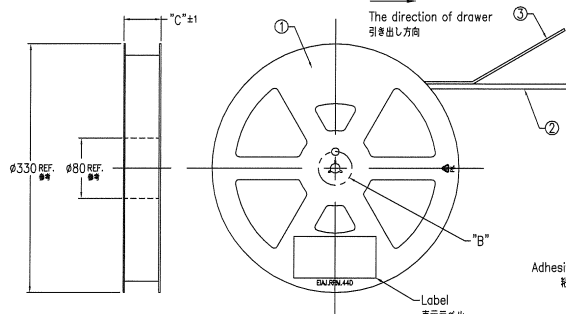

mat'l. code	surface	tolerance	projection	product family	CODE
---	ISO 1302	ISO 406	ISO 1101	59GF FLEX 0.5	JP
l/r description	ecn no	dr	date	title	
				ASSEMBLY	
				0.5mm PITCH CONNECTOR FOR FPC	
				VLL Series	
				dwg no	sheet 5 of 5 size
				10051922	A3
				type	Product Customer Drawing
					Rev.
					H