

PRODUCT NUMBER  
SEE TABLE

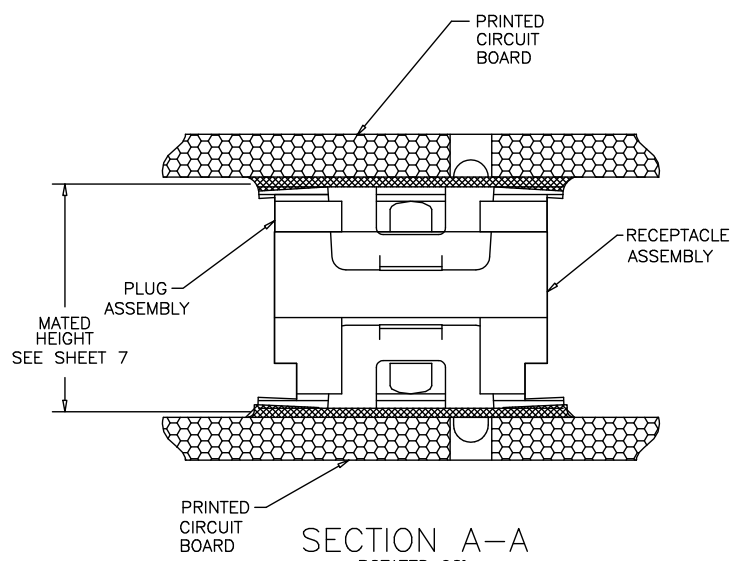
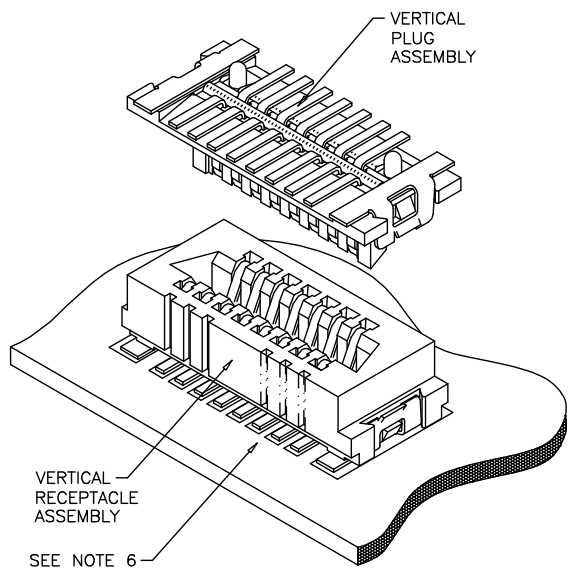

mat'l. code		surface ISO 1302		tolerance ISO 406 ISO 1101		projection		product family CONAN®	
ltr	ecm no	dr	date	tolerances unless otherwise specified		INCH/MM		title	
A	-	GM	2013-01-14	angles	linear	scale 5:1		CONAN® CONNECTOR ASSEMBLY	
B	ELX-N-13992	GM	2013-02-05	0°±2'	linear	scale 5:1		dwg no	
C	ELX-N-14209	GM	2013-03-07			scale 5:1		sheet 1 of 7	
-	-	-	-	dr	GM SUN	2013-01-14		size	
-	-	-	-	enrg	GM SUN	2013-01-14		A3	
-	-	-	-	chr	RICK BIAN	2013-01-14		10124017	
-	-	-	-	appd	RICK BIAN	2013-01-14		type	
sheet index	revision sheet	C	C	C	C	C	C	Product Customer Drawing	
		1	2	3	4	5	6		

PDS: Bw :C

STATUS: Released Printed: Mar 08, 2013

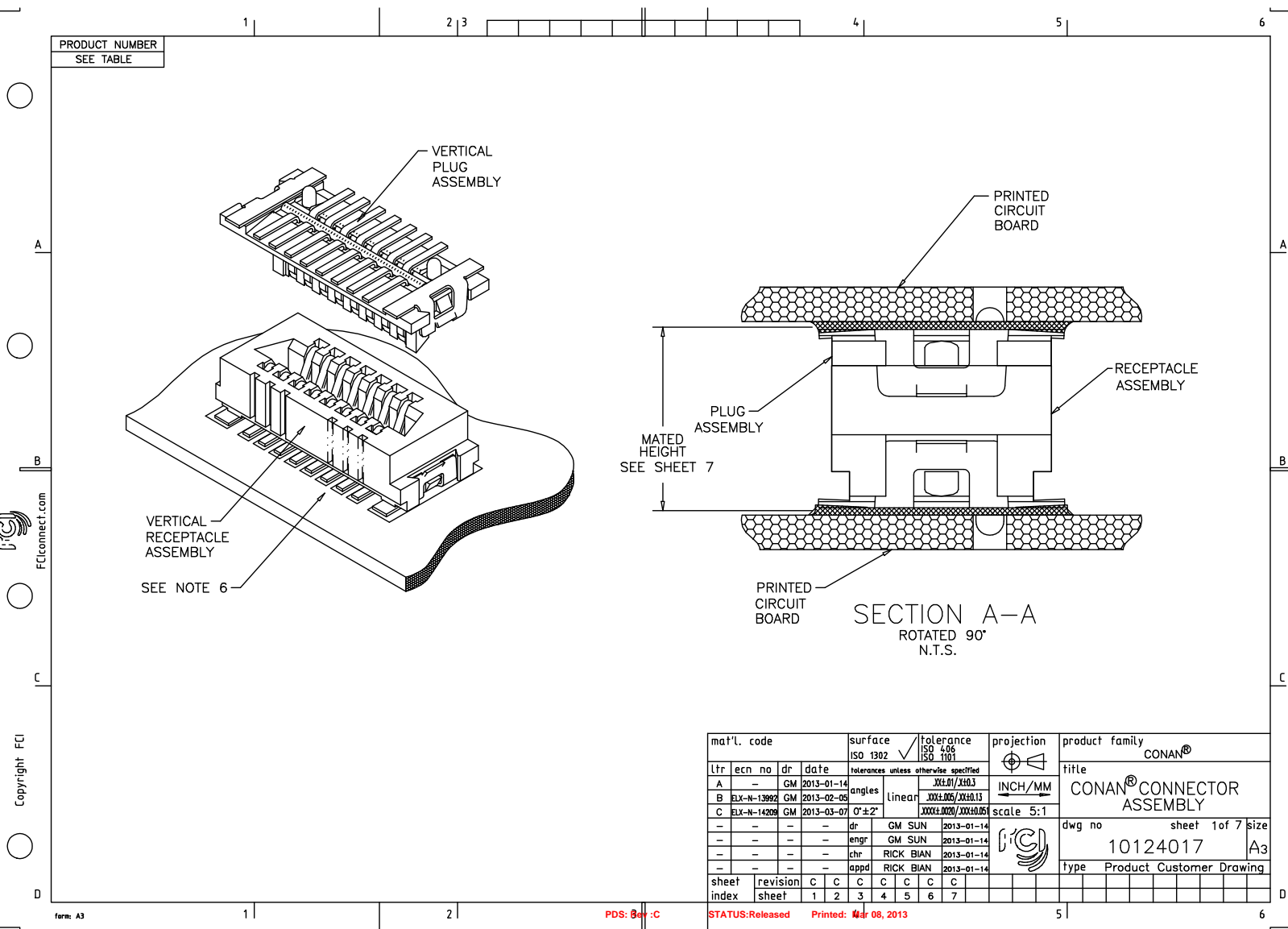

Copyright FCI

PRODUCT NUMBER  
SEE TABLE

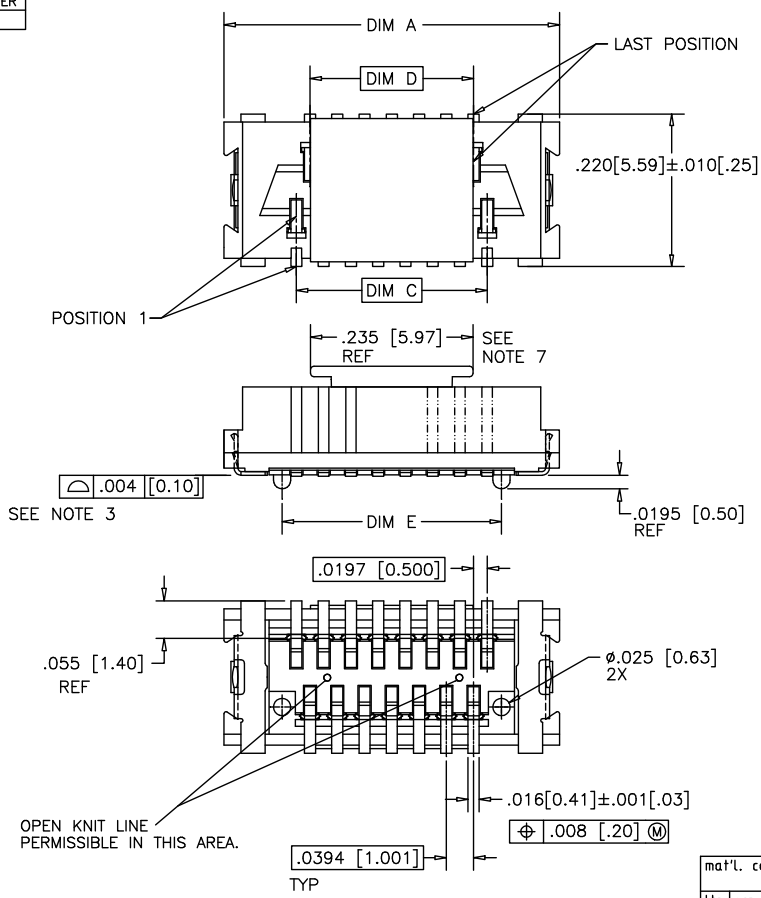

RECEPTACLE

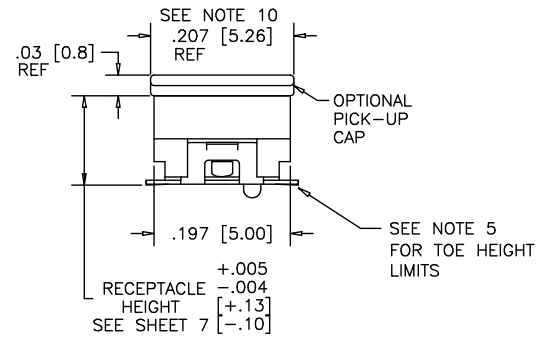

Copyright FCI  
FCIconnect.com

mat'l. code	surface ISO 1302	tolerance ISO 406 ISO 1101	projection INCH/MM	product family CONAN®
ltr	ecn no	dr	date	title CONAN® CONNECTOR ASSEMBLY
c				dwg no 10124017
	angles	Linear	scale 5:1	sheet 2 of 7 size A3
	0°±2'	XXX±.01/XX±0.3 XXX±.005/XX±0.13 XXX±.000/XX±0.05		type Product Customer Drawing
	dr	GM SUN	2013-01-14	
	enr	GM SUN	2013-01-14	
	chr	RICK BIAN	2013-01-14	
	appd	RICK BIAN	2013-01-14	
sheet index	revision sheet			

PRODUCT NUMBER  
SEE TABLE

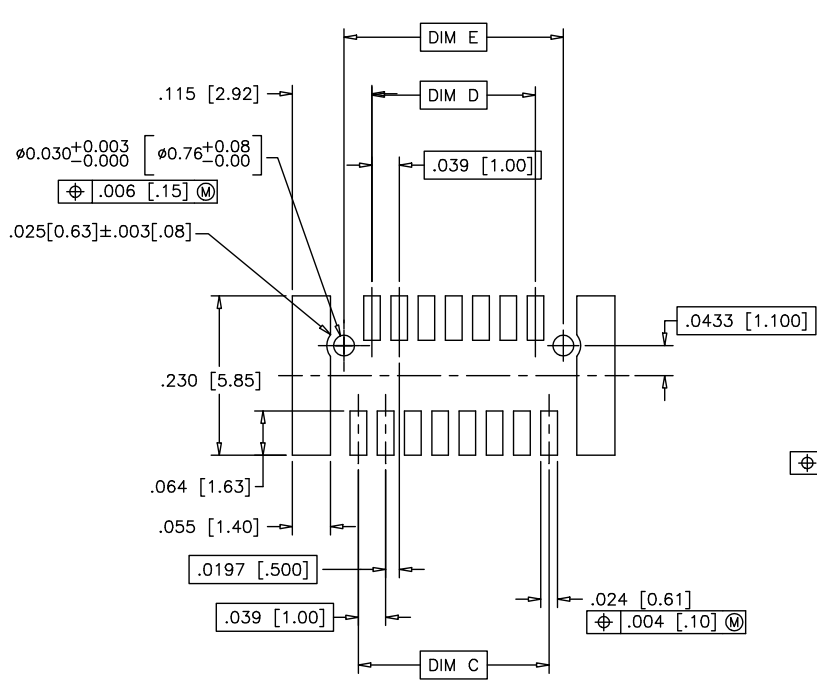

RECOMMENDED  
PAD LAYOUT  
FOR RECEPTACLE

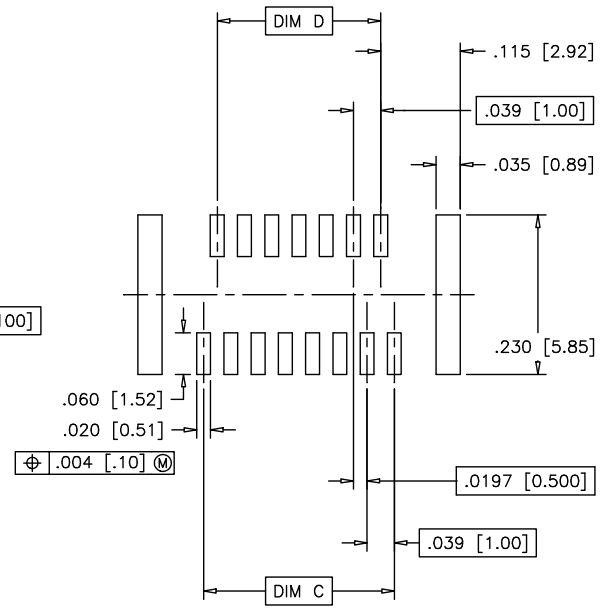

RECOMMENDED  
STENCIL LAYOUT  
FOR RECEPTACLE

mat'l. code		surface ISO 1302		tolerance ISO 406 ISO 1101		projection FIRST ANGLE		product family CONAN®	
ltr	ecm no	dr	date	tolerances unless otherwise specified		INCH/MM		title CONAN® CONNECTOR ASSEMBLY	
c				angles	Linear	scale 5:1		dwg no 10124017	
				0°±2°	XXX±.01/XX±0.3 XXX±.005/XX±0.13 XXX±.002/XX±0.05			sheet 3 of 7 size A3	
				dr	GM SUN	2013-01-14		type Product Customer Drawing	
				enr	GM SUN	2013-01-14			
				chr	RICK BIAN	2013-01-14			
				appd	RICK BIAN	2013-01-14			
sheet index	revision sheet								

PRODUCT NUMBER  
SEE TABLE

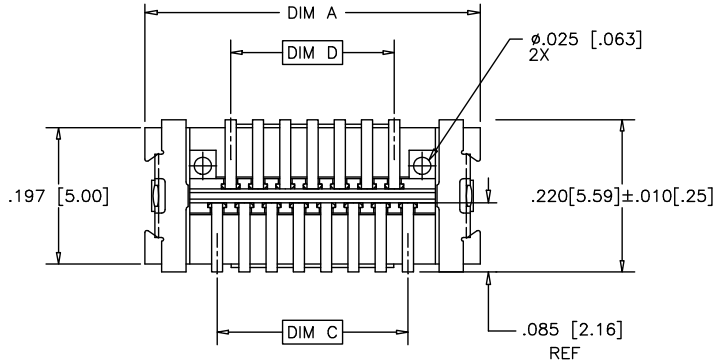

PLUG

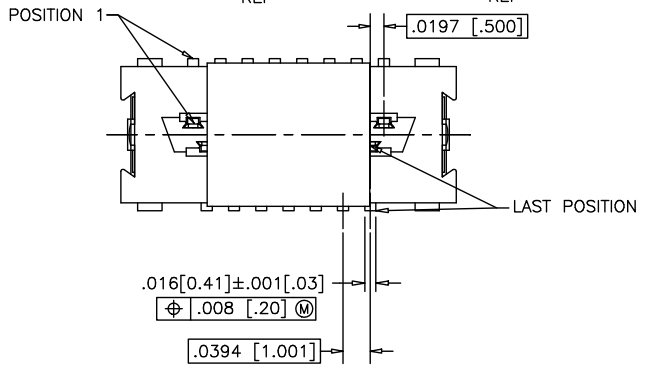
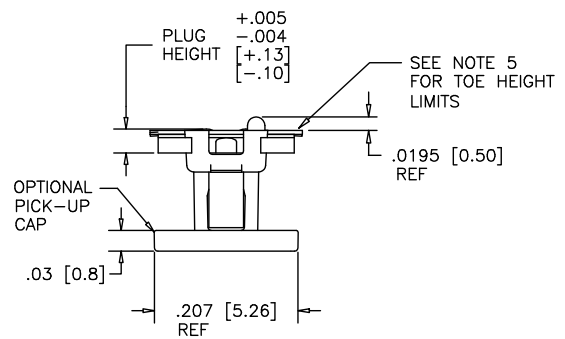
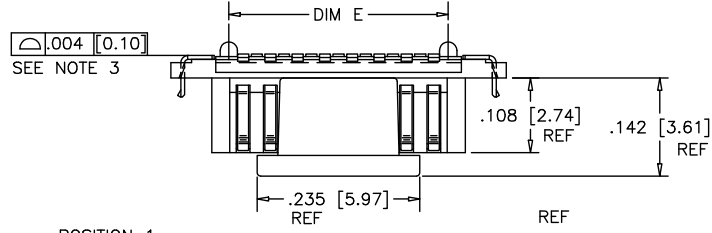

mat'l. code		surface	tolerance	projection	product family
ISO 1302		ISO 406	ISO 1101		CONAN®
tolerances unless otherwise specified		linear	XX1.01/XX0.3		INCH/MM
angles		0°±2'	XX1.05/XX0.13	scale 5:1	CONAN® CONNECTOR ASSEMBLY
dr		GM SUN	2013-01-14		dwg no
engr		GM SUN	2013-01-14		10124017
chr		RICK BIAN	2013-01-14		sheet 4 of 7
appd		RICK BIAN	2013-01-14		size
sheet index		revision sheet			A3
					type Product Customer Drawing

form: A3

PDS: Rev :C

STATUS: Released Printed: Mar 08, 2013

Copyright FCI  
FCIconnect.com

PRODUCT NUMBER  
SEE TABLE

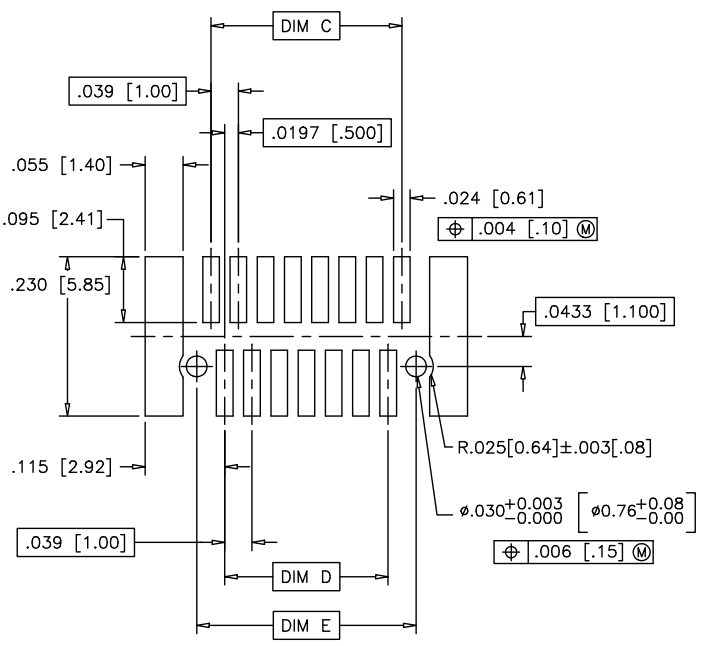

RECOMMENDED  
PAD LAYOUT  
FOR PLUG

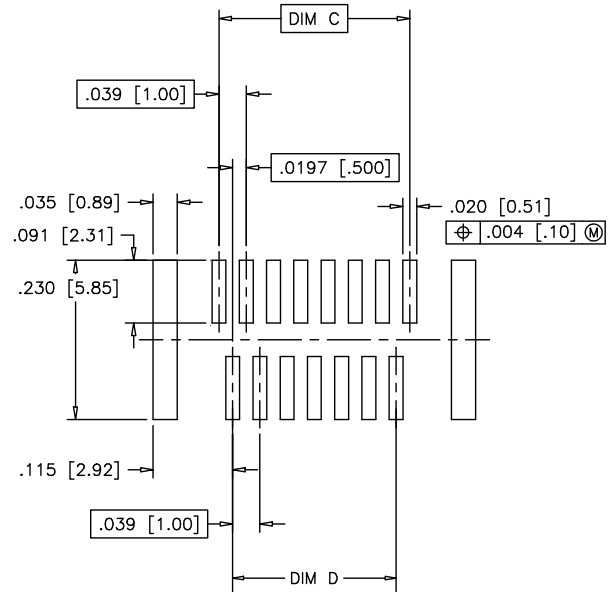

RECOMMENDED  
STENCIL LAYOUT  
FOR PLUG

mat'l. code		surface ISO 1302	tolerance ISO 406 ISO 1101	projection FIRST ANGLE	product family CONAN®
ltr	ecm no	dr	date	tolerances unless otherwise specified	title CONAN® CONNECTOR ASSEMBLY
c				linear XX±.01/XX±0.3 XX±.005/XX±0.13	INCH/MM
				angles 0°±2° XX±.000/XX±0.05	scale 5:1
		dr	GM SUN 2013-01-14		dwg no 10124017 sheet 5 of 7 size A3
		enrg	GM SUN 2013-01-14		type Product Customer Drawing
		chr	RICK BIAN 2013-01-14		
		appd	RICK BIAN 2013-01-14		
sheet index	revision sheet				

PRODUCT NUMBER	POS	DIM "A"	DIM "C"	DIM "D"	DIM "E"
10124017-TCWXY09LF	9	.366 [9.30]	.157 [4.00]	.118 [3.00]	.1990 [5.055]
-TCWXY11LF	11	.406 [10.30]	.197 [5.00]	.157 [4.00]	.2380 [6.045]
-TCWXY15LF	15	.484 [12.30]	.276 [7.00]	.236 [6.00]	.3170 [8.052]
-TCWXY21LF	21	.602 [15.30]	.394 [10.00]	.354 [9.00]	.4350 [11.049]
-TCWXY25LF	25	.681 [17.30]	.472 [12.00]	.433 [11.00]	.5140 [13.056]
-TCWXY31LF	31	.800 [20.30]	.591 [15.00]	.551 [14.00]	.6320 [16.053]
-TCWXY41LF	41	.996 [25.30]	.787 [20.00]	.748 [19.00]	.8290 [21.057]
-TCWXY51LF	51	1.193 [30.30]	.984 [25.00]	.945 [24.00]	1.0260 [26.060]
-TCWXY69LF	69	1.547 [39.30]	1.339 [34.00]	1.299 [33.00]	1.3800 [35.052]

NOTES:

- MATERIALS:  
 RECEPTACLE HOUSING - LCP, UL-94V-0. COLOR: NATURAL.  
 RECEPTACLE TERMINALS - COPPER ALLOY, PLATED WITH GOLD IN CONTACT AREA AND OTHER ALL AREA PLATING G/F WITH AN OVERALL 50u"/1.27u Ni UNDERPLATE.  
 PLUG HOUSING - LCP, UL-94V-0. COLOR: NATURAL.  
 PLUG TERMINALS - COPPER ALLOY, PLATED WITH GOLD IN CONTACT AREA AND OTHER ALL AREA PLATING G/F WITH AN OVERALL 50u"/1.27u Ni UNDERPLATE.  
 HOLD DOWN - COPPER ALLOY, PLATED WITH GOLD FLISH OVER NICKEL.
- REFERENCE GS-12-0977 FOR PRODUCT PERFORMANCE AND ENVIRONMENTAL RESISTANCE DATA.
- SEE TA-774 FOR FURTHER DESCRIPTION OF HOW THIS DIMENSION IS APPLIED.
- RECOMMENDED SOLDER PASTE THICKNESS IS .006 TO .008 INCHES THICK.
- THE TOE HEIGHT OF THE SOLDER TAIL SHALL BE MEASURED FROM THE LOWEST POINT OF THE .004 CO-PLANARITY GRAVITY PLANE. THIS MEASUREMENT IS NOT TO EXCEED A WINDOW OF .000 TO .007 INCHES.
- THREE SLOTS MAY BE LOCATED AT EITHER END OF HOUSING.
- THE HOUSING WILL WITHSTAND EXPOSURE TO 260°C PEAK TEMPERATURE FOR 30 SECONDS IN A CONVECTION INFRA RED OR VAPOR PHASE REFLOW OVEN. SEE APPLICATION/PROCEDURES IF THEY ARE AVAILABLE
- PRODUCT WITH "LF" AT THE END MEETS EUROPEAN UNION DIRECTIVES AND OTHER COUNTRY REGULATION AS DESCRIBED IN GS-22-008.

mat'l. code	surface ISO 1302	tolerance ISO 406 ISO 1101	projection	product family CONAN®
ltr	ecn no	dr	date	title
C				CONAN® CONNECTOR ASSEMBLY
	angles	Linear	INCH/MM	scale 5:1
	0°±2"	XXX±.01/XX±0.3 XXX±.005/XX±0.13 XXX±.002/XX±0.05		
	dr	GM SUN	2013-01-14	dwg no
	enrg	GM SUN	2013-01-14	sheet 6 of 7
	chr	RICK BIAN	2013-01-14	size
	appd	RICK BIAN	2013-01-14	A3
sheet index	revision sheet			type Product Customer Drawing

form: A3

1

2

PDS: Bay :C

STATUS:Released Printed: Mar 08, 2013

5

6

Copyright FCI  
FCIconnect.com

PRODUCT NUMBER  
SEE TABLE

CONAN® ASSEMBLY PART NUMBER

10124017 - T C W X Y ZZ LF

LEAD FREE  
SEE NOTE 8

TYPE	T
PLUG NO PEGS	0
PLUG WITH PEGS	1
RECEPTACLE NO PEGS	2
RECEPTACLE WITH PEGS	3

PICK AND PLACE CAP OR TAPE	C
WITHOUT CAP OR TAPE	0
WITH CAP	1
WITH TAPE (RECEPTACLE ONLY)	2

PACKAGING	W
TUBE	2
PRESSURE SEALED TAPE & REEL	3

Y	PLUG HEIGHT	RECEPTACLE HEIGHT	MATED HEIGHT	+0.010 -0.008 [+.25] [-.20]	ZZ	NUMBER OF POSITIONS
1	.034 [.86]	.129 [3.28]	.163 [4.15]		09	9
2	.048 [1.23]		.177 [4.50]		11	11
3	.068 [1.73]		.197 [5.00]		15	15
4	.107 [2.72]	SEE Y=1 FOR ALL RECEPTACLES	.236 [6.00]		21	21
5	.1465 [3.721]		.276 [7.00]		25	25
					31	31
					41	41
					51	51
					69	69

X	PLATING
1	15u" Au ON CONTACT AREA, OTHER ALL AREA PLATING G/F.
2	30u" Au ON CONTACT AREA, OTHER ALL AREA PLATING G/F.

EXAMPLE: 10124017-3131125LF  
IS A CONAN® RECEPTACLE ASSEMBLY,  
HAVING PEGS AND WITH A PICK AND PLACE CAP.  
IT IS .13 [3.2] HIGH AND 25 POSITIONS AND IS  
PACKAGED IN PRESSURE SEALED TAPE, REEL AND LEAD FREE.

mat'l. code		surface	tolerance	projection	product family
ISO 1302		ISO 406	ISO 1101		CONAN®
tolerances unless otherwise specified		linear			INCH/MM
ltr	ecr no	dr	date	scale 5:1	title
C					CONAN® CONNECTOR ASSEMBLY
					dwg no
					10124017
					sheet 7 of 7
					A3
					type
					Product Customer Drawing

PDS: Bep :C

STATUS: Released

Printed: Mar 08, 2013