

NOTES:

- MATERIAL:  
 BOX: FIBREBOARD, CORRUGATED, DOUBLE WALL.  
 COVER TAPE: PET, 120C° HEAT-RESISTANT TEMPERATURE, TRANSPARENT COLOR.  
 CARRIER TAPE: POLYSTYRENES, 120C° HEAT-RESISTANT TEMPERATURE, TRANSPARENT COLOR.  
 REEL: HIPS, 70C° HEAT-RESISTANT TEMPERATURE, BLUE COLOR.  
 BAG: POLYETHYLENES, 100C° HEAT-RESISTANT TEMPERATURE, TRANSPARENT COLOR.
- EACH BAG SHALL BE INCLUDED DESICCANT.
- PEELING STRENGTH: 0.1 ~ 1.3 N (10 ~ 130 GRAMS).
- PEELING SPEED: 300 mm/min.

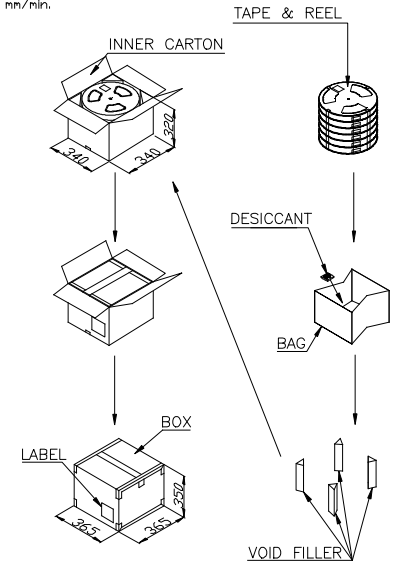

STANDARD TAPE & REEL  
(FOR -XXOLF)

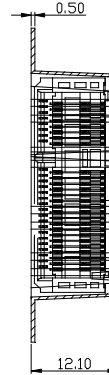
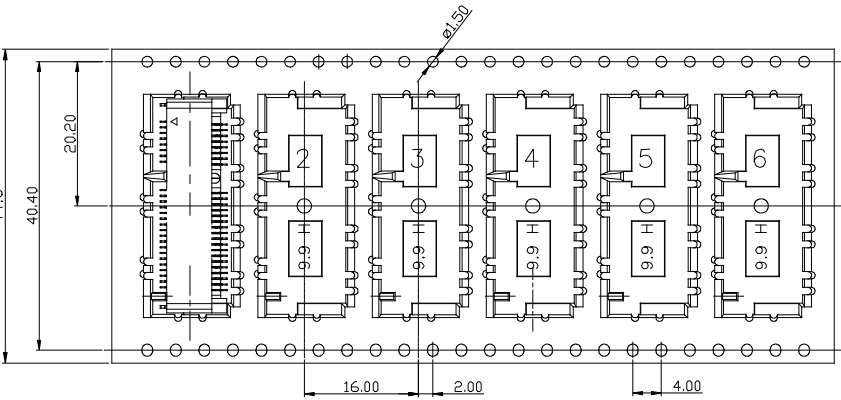
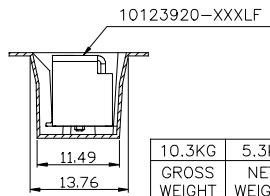

10.3KG	5.3KG	300	6	1800
GROSS WEIGHT	NET WEIGHT	PCS/ REEL	REEL/ BOX	PCS/ BOX

mat'l. code	surface	tolerance	projection	product family
itr	ecn	no	dr	date
A	TAI	2013-01-29	TAI	2013-01-29
B	ELX-T-14985	TAI	2013-06-17	2013-06-17
tolerances unless otherwise specified		ASME Y14.5	MM	title
angles	SI	X.X ± 0.30	MM	0.80MM PITCH MINI PCI EXPRESS
SI	IN	X.XX ± 0.20	MM	HIGH=9.9mm 52 PIN CONNECTOR
X'±4"		X.XXX ± 0.15	scale	FCI
dr	KENNY TAI	2013-01-29		dwg no
enr	KENNY TAI	2013-01-29		sheet 2 of 3
chr	KENNY TAI	2013-01-29		10123920
appd	PM ZHENG	2013-01-29		A4
sheet index	revision sheet	B B B		type
1	2	3		CUSTOMER Drawing

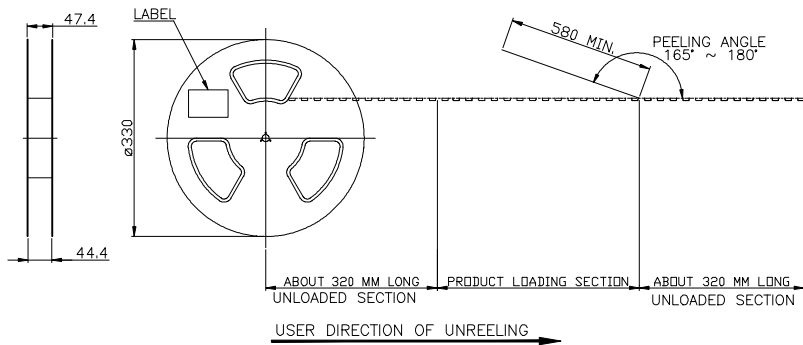

NOTES:

1. MATERIAL:  
 BOX: FIBREBOARD, CORRUGATED, DOUBLE WALL.  
 COVER TAPE: PET, 120C° HEAT-RESISTANT TEMPERATURE, TRANSPARENT COLOR.  
 CARRIER TAPE: POLYSTYRENES, 120C° HEAT-RESISTANT TEMPERATURE, TRANSPARENT COLOR.  
 REEL: HIPS, 70C° HEAT-RESISTANT TEMPERATURE, BLUE COLOR.  
 BAG: POLYETHYLENES, 100C° HEAT-RESISTANT TEMPERATURE, TRANSPARENT COLOR.
2. EACH BAG SHALL BE INCLUDED DESICCANT.
3. PEELING STRENGTH: 0.1 ~ 1.3 N (10 ~ 130 GRAMS).
4. PEELING SPEED: 300 mm/min.

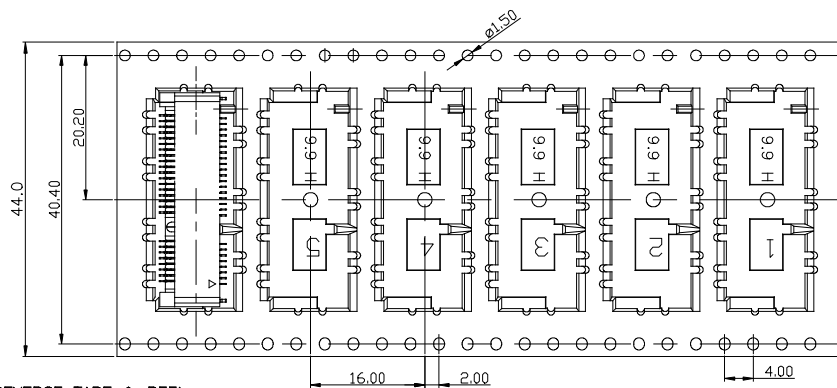
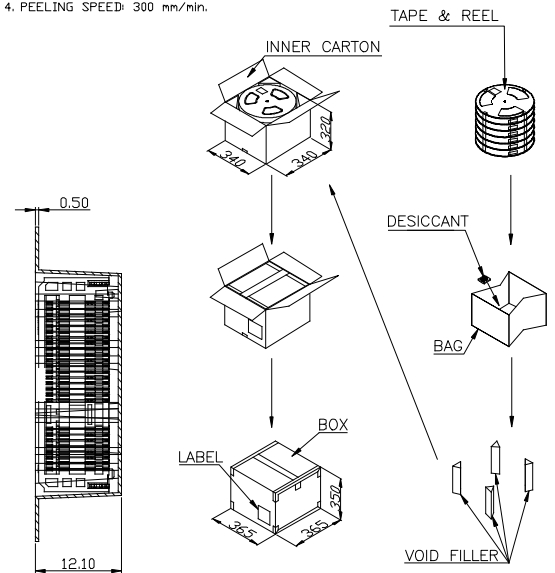

REVERSE TAPE & REEL (FOR -XX1LF)

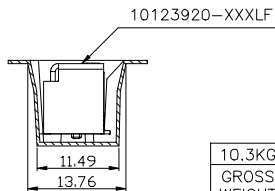

10.3KG	5.3KG	300	6	1800
GROSS WEIGHT	NET WEIGHT	PCS/ REEL	REEL/ BOX	PCS/ BOX

mat'l. code		surface	tolerance	projection	product family
A		ASME Y14.5	ASME Y14.5	MM	0.80MM PITCH MINI PCI EXPRESS
B		tolerances unless otherwise specified	angles	scale	HIGH=9.9mm 52 PIN CONNECTOR
B		ELX-T-14985	TAI	2013-06-17	FCI
sheet index		revision sheet	B	B	B
1		2	3		