



## 24-Bit Ultra-Low Power Serializer / Deserializer Supporting Single and Dual Displays

### Features

- Ultra-Low Operating Power: ~4mA at 5.44MHz
- Supports Dual-Display Implementations with RGB or Microcontroller Interface
- No External Timing Reference Needed
- SPI Mode Support
- Single Device Operates as a Serializer or Deserializer
- Direct Support for Motorola®-Style R/W Microcontroller Interface
- Direct Support for Intel®-Style /WE, /RE Microcontroller Interface
- 15MHz Maximum Strobe Frequency
- Utilizes Fairchild's Proprietary CTL Serial I/O Technology
- Available in BGA and MLP packages
- Wide Parallel Supply Voltage Range: 1.60 to 3.0V
- Low Power Core Operation:  $V_{DDSA}=2.5$  to 3.0V
- Voltage Translation Capability Across Pair with No External Components
- High ESD Protection: >15kV IEC 61000
- Power-Saving Burst-Mode Operation

### Applications

- Single or Dual 16/18-Bit RGB Cell Phone Displays
- Single or Dual 16/18-Bit Cell Phone Displays with Microcontroller Interface
- Single or Dual Mobile Display at QVGA or HVGA Resolution

### Description

The FIN324C is a 24-bit serializer / deserializer with dual strobe inputs. The device can be configured as a master or slave device through the master/slave select pin (M/S). This allows for the same device to be used as either a serializer or deserializer, minimizing component types in the system. The dual strobe inputs allow implementation of dual-display systems with a single pair of  $\mu$ SerDes. The FIN324C can accommodate RGB, microcontroller, or SPI mode interfaces. Read and write transactions are supported when operating with a microcontroller interface for one or both displays. Unlike other SerDes solutions, no external timing reference is required for operation.

The FIN324C is designed for ultra-low power operation. Reset (/RES) and standby (/STBY) signals put the device in an ultra-low power state. In standby mode, the outputs of the slave device maintain state, allowing the system to resume operation from the last-known state.

The device utilizes Fairchild's proprietary ultra-low power, low-EMI Current Transfer Logic™ (CTL) technology. The serial interface disables between transactions to minimize EMI at the serial interface and to conserve power. CMOS parallel output buffers have been implemented with slew rate control to adjust for capacitive loading and to minimize EMI.

### Related Application Notes

- For additional information, please visit: <http://www.fairchildsemi.com/userdes>
- AN-5058  $\mu$ SerDes™ Frequently Asked Questions
- AN-5061  $\mu$ SerDes™ Layout Guidelines
- AN-6047 FIN324C Reset and Standby

## Ordering Information

Order Number	Package	Operating Temperature Range	Package Description	Packing Method
FIN324CMLX	MLP040A	-30 C to 70 C	40-Terminal Molded Leadless Package (MLP), Quad, JEDEC MO-220, 6mm Square	Tape & Reel
FIN324CGFX	BGA42A	-30 C to 70 C	42-Ball, Ultra Small Scale Ball Grid Array (USS-BGA), JEDEC MO-195, 3.5 x 4.5mm Wide, 0.5mm Ball Pitch	Tape & Reel

 All packages are lead free per JEDEC: J-STD-020B standard.

## Typical Application Diagram

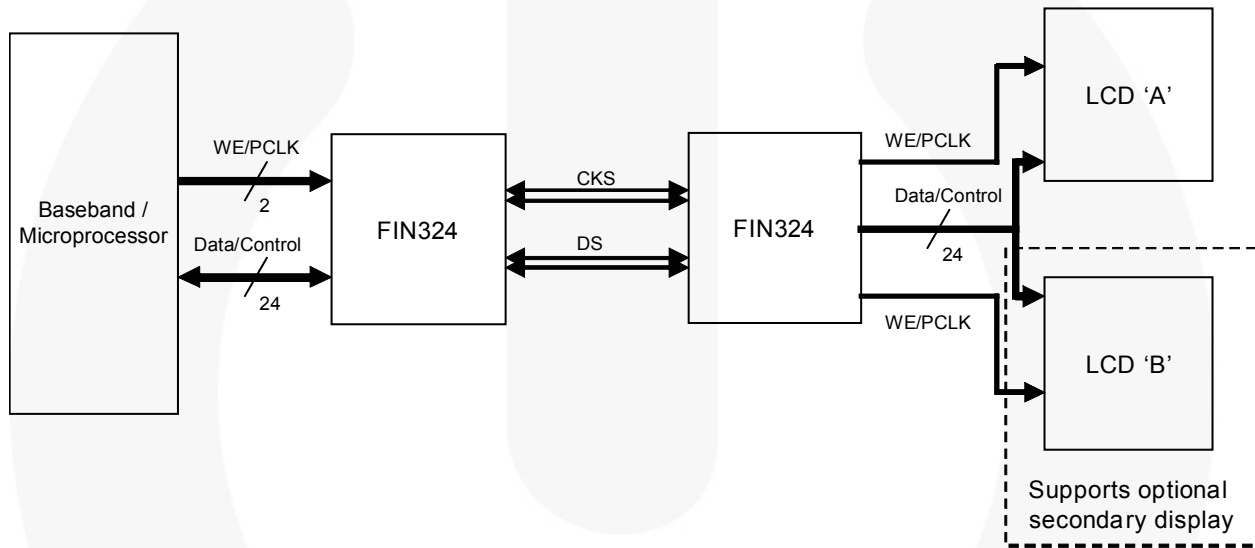

Figure 1. Typical Application Diagram

## Pin Definitions

Pin	I/O Type	# Pins	Description of Signals
M/S	CMOS IN	1	Master/Slave Control Input: The master is tied to the processor. The slave is tied to the display(s). M/S=1 MASTER, M/S =0 SLAVE
/RES	CMOS IN	1	Reset and power-down signal /RES=0: Resets and powers down all circuitry /RES=1: Device enabled
/STBY	CMOS IN	1	Master standby signal /STBY=0: Device powered down /STBY=1: Device enabled
SLEW	CMOS IN	1	Slave output slew rate control SLEW=1: Fast edge rate SLEW=0: Slow edge rate
PAR/SPI	CMOS IN	1	Parallel / SPI display interface select PAR/SPI=1: Parallel Interface PAR/SPI=0: SPI Interface using STRB0 and WCLK0
CKSEL	CMOS IN	1	Master clock source select input. CKSEL=1: STRB1 and WCLK1 Active CKSEL=0: STRB0 and WCLK0 Active
DP[17:0]	CMOS I/O	18	Parallel data I/O. I/O direction controlled by M/S pin and R/W internal state. DP[6] SPI mode SCLK signal pin when PAR/SPI=0 (Slave Only) DP[7] SPI mode SDAT signal pin when PAR/SPI=0(Slave Only)
CNTL[5:0]	CMOS I/O	6	Parallel data I/O. I/O direction controlled by M/S pin M/S=1: Inputs M/S=0: Outputs
R/W	CMOS I/O	1	Read / Write input control or output signal. M/S=1: Input M/S=0: Output  Functional operation: R/W=1: Read R/W=0: Write
STRB0 STRB1	CMOS IN	2	Word latch or pixel clock input.
WCLK0 WCLK1	CMOS OUT	2	Word latch or pixel clock output.
SCLK SDAT /CS	CMOS I/O	2	SPI mode signal pins. The master SCLK input is shared with CNTL[5] when M/S=1 and PARI/SPI=0. The master SDAT input is shared with CNTL[4] when M/S=1 and PARI/SPI=0. The master /CS input is shared with STRB0 when M/S=1 and PAR/SPI=0. The slave SCLK output is shared with DP[6] and CNTL[5] when M/S=0 and PAR/SPI=0. The slave SDAT output is shared with DP[7] and CNTL[4] when M/S=0 and PAR/SPI=0. The slave /CS output is shared with WCLK0 when M/S=0 and PAR/SPI=0.
CKS+ CKS-	Differential Serial I/O	2	Serial clock differential signal <sup>(1)</sup>
DS+ DS-	Differential Serial I/O	2	Serial data differential signal <sup>(1)</sup>
VDDP	Supply	1	Power supply for parallel I/O and internal circuitry.
VDDS	Supply	1	Power supply for serial I/O.
VDDA	Supply	1	Power supply for internal bit clock generator.
GND	Supply	1-3	Ground Pins: BGA - C1 and D2; E3 is for supplier use only and must be tied to ground. MLP - center pad; Pin 12 is for supplier use only and must be tied to ground.

**Note:**

1. Serial I/O signals are swapped on the slave so system traces do not have to cross between master and slave.

## Pin Assignments

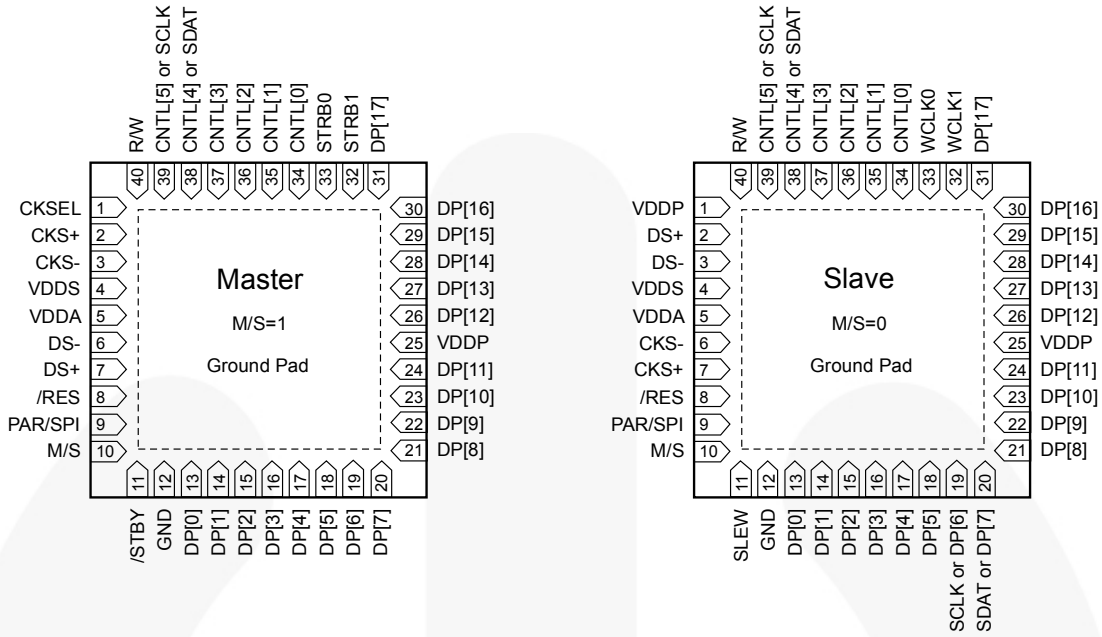
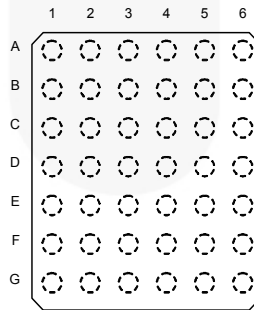

Figure 2. MLP Pin Assignments (40 Pins, 6x6mm, .5mm Pitch, Top View)

42 FBGA Package  
3.5mm x 4.5mm  
(.5mm Pitch)  
(Top View)



Master (M/S = 1)						
	1	2	3	4	5	6
A	R/W	CNTL[4] or SDAT	CNTL[2]	STROB0	DP[17]	DP[16]
B	CKSEL	CNTL[5] or SCLK	CNTL[3]	STROB1	DP[15]	DP[14]
C	GND	VDDP	CNTL[1]	CNTL[0]	DP[13]	DP[12]
D	CKS+	GND	M/S	DP[11]	DP[9]	DP[10]
E	CKS-	VDDS	GND	DP[2]	DP[7]	DP[8]
F	DS-	VDDA	PAR/SPI	DP[0]	DP[4]	DP[6]
G	DS+	/RES	/STBY	DP[1]	DP[3]	DP[5]

Slave (M/S = 0)						
	1	2	3	4	5	6
A	R/W	CNTL[4] or SDAT	CNTL[2]	WCLK0	DP[17]	DP[16]
B	VDDP	CNTL[5] or SCLK	CNTL[3]	WCLK1	DP[15]	DP[14]
C	GND	VDDP	CNTL[1]	CNTL[0]	DP[13]	DP[12]
D	DS+	GND	M/S	DP[11]	DP[9]	DP[10]
E	DS-	VDDS	GND	DP[2]	DP[7] or SDAT	DP[8]
F	CKS-	VDDA	PAR/SPI	DP[0]	DP[4]	DP[6] or SCLK
G	CKS+	/RES	SLEW	DP[1]	DP[3]	DP[5]

Figure 3. BGA Pin Assignments

## System Control Pins

**(M/S) Master / Slave Selection:** A given device can be configured as a master or slave device based on the state of the M/S pin.

**Table 1. Master/Slave**

M/S	Configuration
0	Slave Mode
1	Master Mode

**(PAR/SPI) SPI Mode Selection:** The PAR/SPI signal configures STRB0(WCLK0) for SPI mode write operation. STRB1(WCLK1) always operates in parallel mode. Control signals CNTL[5:0] all pass in SPI mode. In SPI mode, the SCLK signal is used to strobe the serializer. SPI mode supports SPI writes only.

**Table 2. Channel 0 PAR/SPI Configuration**

PAR /SPI	M/S=1 MASTER	M/S=0 SLAVE
0	SPI Mode SDAT=CNTL[4] SCLK=CNTL[5] /CS=STRB0	SPI Mode SDAT=DP[7] & CNTL[4] SCLK=DP[6] & CNTL[5] /CS=WCLK0
1	Parallel Mode	Parallel Mode

**(CKSEL) Strobe Selection Signal:** The CKSEL signal exists only on the master device and determines which strobe signal is active. The active strobe signal is selected by CKSEL and PAR/SPI inputs.

**Table 3. PAR/SPI**

PAR /SPI	CKSEL	Master Strobe Source	Slave Strobe Source
0	0	CNTL[5]	DP[6] & CNTL[5]
0	1	STRB1	WCLK1
1	0	STRB0	WCLK0
1	1	STRB1	WCLK1

**(/RES, /STBY) Reset and Standby Mode Functionality:** Reset and standby mode functionality is determined by the state of the /RES and /STBY signals for the master device and the /RES and internal standby-detect signal for the slave device. The /RES control signal has a filter that rejects spurious pulses on /RES.

**Table 4. Reset and Standby Modes**

/RES	/STBY <sup>(2)</sup>	Master	Slave
0	X	Reset Mode	Reset Mode
1	0	Standby Mode	Standby Mode <sup>(3)</sup>
1	1	Operating Mode	Operating Mode

**Note:**

- The slave device is put into standby mode through control signals sent from the master device.

**Table 5. Reset and Standby Mode States**

Pin	Master Reset / Standby	Slave Reset	Slave Standby
DP[17:0]	Disabled	Low	Last data
CNTL[5:0]	Disabled	Low	Last data
STRB[0:1] (WCLK[0:1])	Disabled	High	High

**(SLEW) Slew Control:** The slew control operates only when in slave mode. This signal changes the edge rate of the DP[17:0], CNTL[5:0], R/W, WCLK1, and WCLK0 signals to optimize edge rate for the load being driven. Master read mode outputs have “slow” edge rates. See the *AC Deserializer Specifications table* for “slow” and “fast” edge rates.

**Table 6. Slew Rate Control**

/STBY (SLEW)	Slave M/S=0
0	“Slow”
1	“Fast”

## CMOS I/O Signals

### System Control Signals

The system control signals consist of M/S, /RES, /STBY(SLEW), PAR/SPI, and CKSEL. For connectivity flexibility, these signals are over-voltage tolerant to the maximum supply voltage connected to the device. This allows these signals to be tied HIGH to either a V<sub>DD5</sub> or V<sub>DDP</sub> supply without static current consumption. These signals are all CMOS inputs and should never be allowed to float.

### Parallel I/O Signals

The parallel data port signals consist of the DP[17:0], CNTL[5:0], R/W, and STRB1(0)(WCLK1(0)) signals. These signals have built-in voltage translation, allowing the signals of the master and slave to be connected to different V<sub>DDP</sub> supply voltages.

## Serial I/O Signals

### CTL I/O Technology

The serial I/O is implemented using Fairchild's proprietary differential CTL I/O technology. During data transfers, the serial I/O are powered up to a normal operating mode around .5V. Upon completion of a data transfer, the serial I/O goes to a lower power mode around V<sub>DD5</sub>.

### Serial I/O Orientation Logic

The serial I/O signal traces should not cross between the master and the slave. The pin locations have been designed to eliminate the need to cross traces. See Table 7, Figure 4 and Figure 5.

**Table 7. Serial Pin Orientation**

Package	Master (M/S=1) (Pad/Pin #)				Slave (M/S=0) (Pad/Pin #)			
	CKS+	CKS-	DS-	DS+	CKS+	CKS-	DS-	DS+
MLP	2	3	6	7	7	6	3	2
BGA	D1	E1	F1	G1	G1	F1	E1	D1

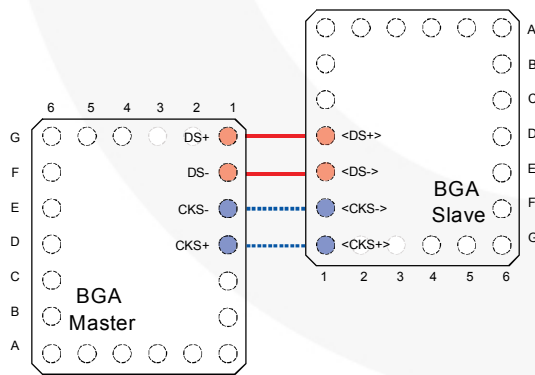

**Figure 4. BGA Pair**

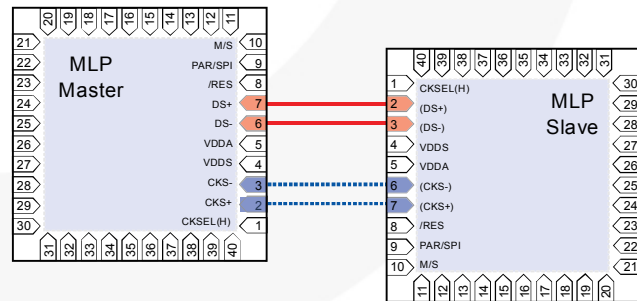

**Figure 5. MLP Pair**

## Master/Slave READ Transactions

Read transactions have two phases: The Read-Control Phase, where CNTL[5:0], R/W, CKSEL are transmitted to the deserializer; and the Read-Data Phase, where the DP[17:0] signals of the slave are read and transmitted back to the master device. The slave device generates its own strobe signal for latching in the data. Slave data must be valid prior to the WCLKn signal going HIGH.

### Master Serializer Operation (Read Control Phase)

When the R/W signal is asserted HIGH and the STROBE signal transitions LOW, the Read-Control Phase of the read cycle is initiated. The R/W signal must not transition until the READ cycle completes. For a READ transaction, only eight control signals are captured. The 18 DP bits are ignored during the READ operation. The following sequence must occur for data to be serialized properly:

1. CPU selects input strobe source (CKSEL= 0 or 1).
2. CPU sends signals (R/W=1, CKSEL, CNTL[5:0]).
3. CPU sends LOW STROBE signal.

### Slave Deserializer Operation (Read-Control Phase)

1. Captures data from serial transfer.
2. Internally decodes that this is a READ transaction.
3. Outputs control signals and prepares DP pins to accept data.
4. Outputs falling edge of WCLK pulse.

### Slave Serializer Read Operation (Read-Data Phase)

The slave serializer is enabled on the tail end of the Read-Control Phase of operation. The operation of the serializer is identical to the master serialization except that the strobe signal is generated internally and only the data bits DP[17:0] are captured.

1. Display device outputs data onto DP bus on falling edge of WCLK.
2. Captures parallel data on generated rising edge of WCLK signal.
3. Serializes data stream.

### Master Deserializer Read Operation (Read-Data Phase):

1. Receives valid serial stream.
2. Outputs data DP[17:0].
3. CPU asserts rising edge of strobe signal to capture data.

---

## SPI WRITE transaction

SPI mode is activated by asserting the PAR/SPI signal low on both the master and slave device. A SPI write is only performed when CKSEL=0. During a SPI transaction, SCLK must be connected to CNTL[5] and is the strobe source for serialization. SDAT is on CNTL[4] and all of the remaining control signals and STRB0 are serialized. STRB0 should be connected to the SPI mode chip select.

On the rising edge of SCLK, all eight control signals (CNTL[5:0], R/W, CKSEL) are captured and serialized. The data signals are not sent. The deserializer captures the serial stream and outputs it to the parallel port.

As shown in Table 2, SDAT and SCLK are output on multiple pins. The DP[7] and DP[6] connections can be used for displays with dual-mode operation and the data pins are multiplexed with the SPI signals. CNTL[5] and CNTL[4] signals can be used when the signals are not multiplexed.

## Application Diagrams

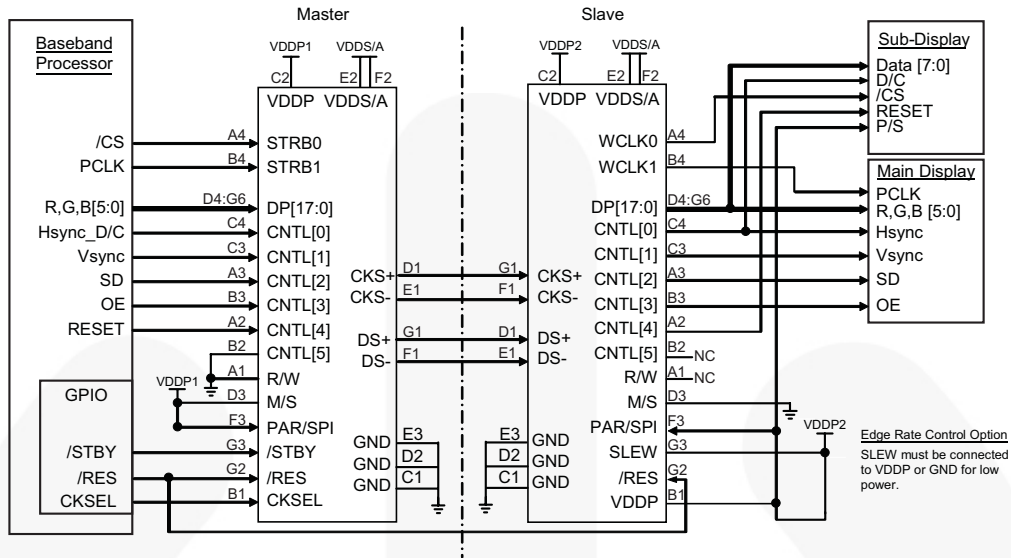

**Notes:**

1. Write-only Interface.
2. Unused slave output pin must be NC (No Connection).
3. /CS used to strobe sub-display data.
4. PCLK used for RGB mode.
5. Pin numbers for BGA package.

**Figure 6. Dual Display with Parallel RGB Main Display and 6800-Style Microcontroller Sub-Display**

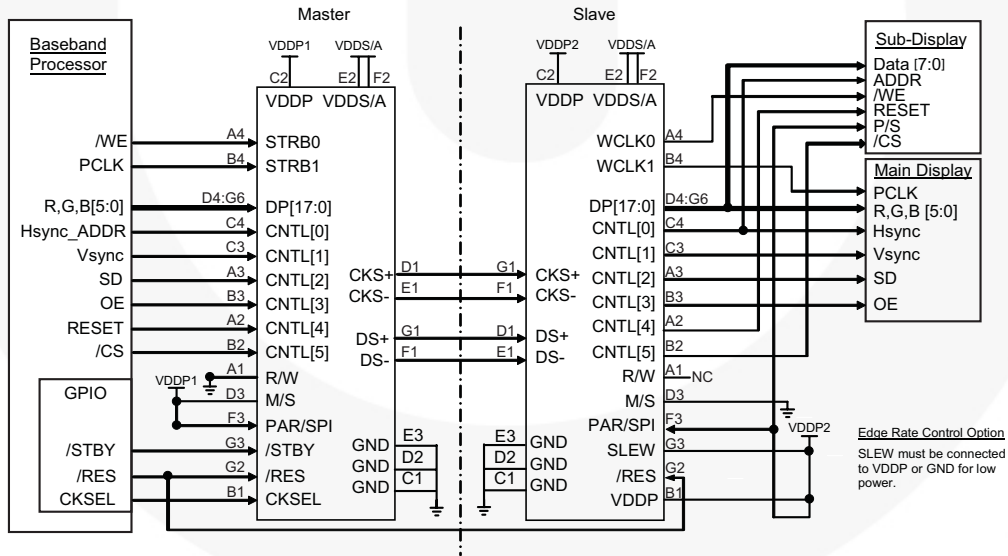

**Notes:**

1. Write-only Interface.
2. Unused slave output pin must be NC (No Connection).
3. /WE used to strobe sub-display data.
4. PCLK used for RGB mode.
5. Pin numbers for BGA package.

**Figure 7. Dual Display with Parallel RGB Main Display and x86-Style Microcontroller Sub-Display**



### Application Diagrams (Continued)

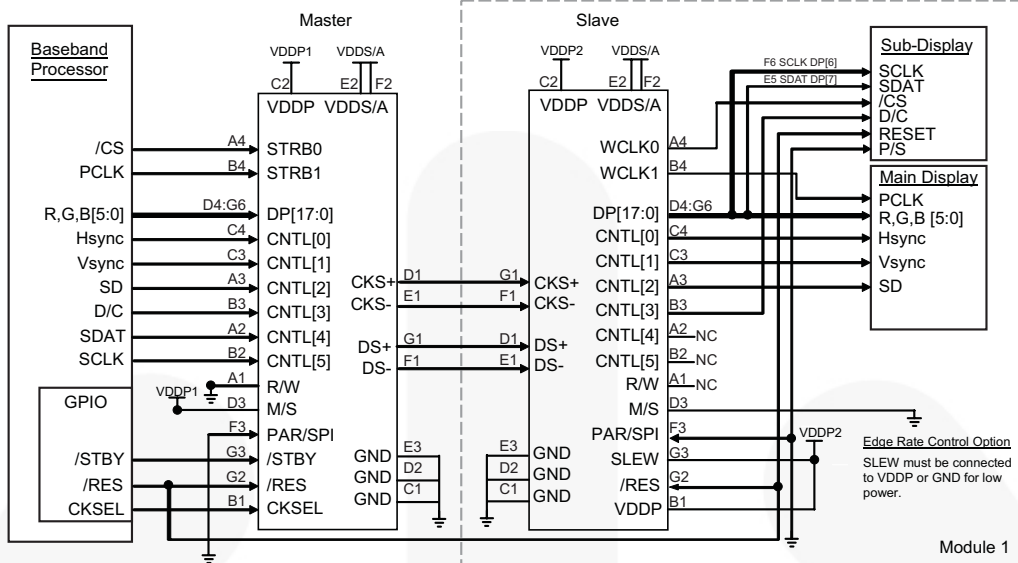

**Notes:**

1. Write-only interface (R/W hardwired LOW).
2. SPI sub-display interface PAR/SPI=LOW for both master and slave.
3. SCLK connected to CNTL[5]; SDAT connected to CNTL[4].
4. Shared data pin SDAT; SCLK connections on sub-display.
5. Unused slave output pin must be NC (No Connection).
6. Pin numbers for BGA package.

**Figure 8. Dual Display with RGB Main Display and SPI Sub-Display Interface**

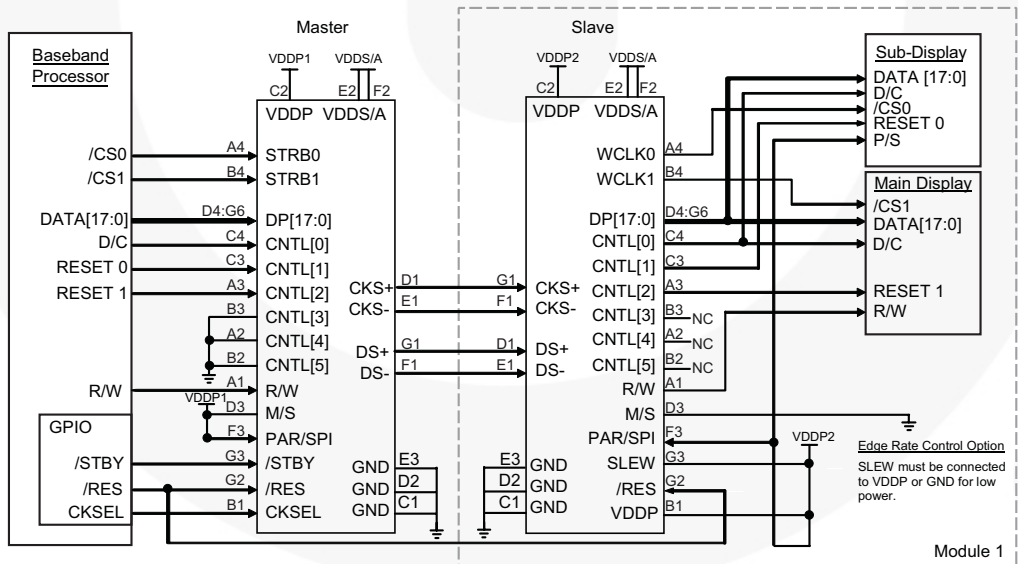

**Notes:**

1. R/W interface. R/W signal connected to baseband microprocessor.
2. Unused slave output pin must be NC (No Connection).
3. PAR/SPI connected HIGH to indicate parallel operation.
4. Pin numbers for BGA package.

**Figure 9. R/W Dual Display with Parallel Microcontroller Main Display and Sub-Display**

## Application Diagrams (Continued)

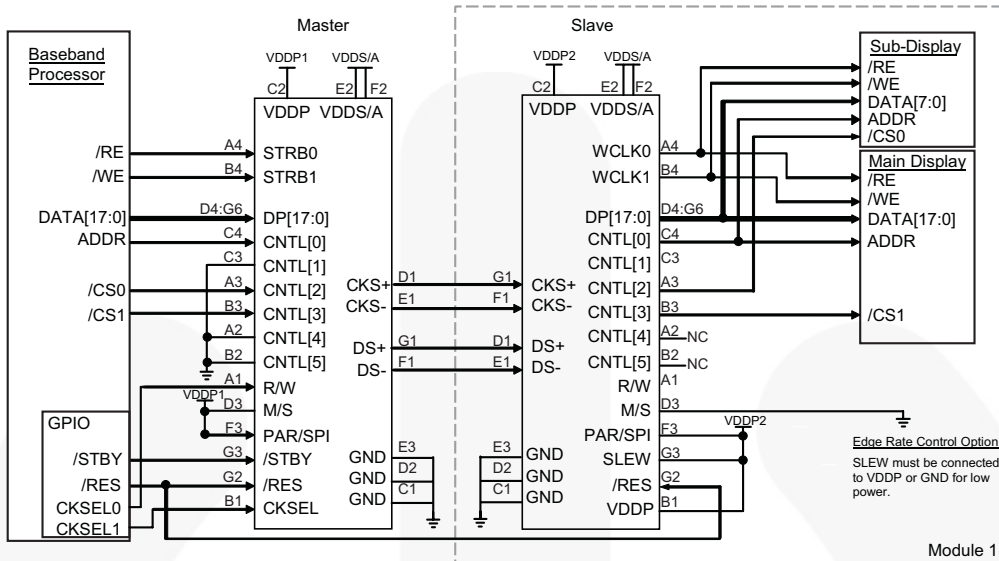

**Notes:**

1. Dual display R/W Intel® interface.
2. Unused slave output pin must be NC (No Connection).
3. GPIO signal used to select READ or WRITE functionality. Connected to CKSEL and R/W.
4. Displays selected via the chip selects.
5. Pin numbers for BGA package.

**Figure 10. Dual R/W x86-Style Microcontroller Display Interface**

## Additional Application Information

**Flex Cabling:** The serial I/O information is transmitted at a high serial rate. Care must be taken implementing this serial I/O flex cable. The following best practices should be used when developing the flex cabling or Flex PCB.

- Keep all four differential Serial Wires the same length.
- Do not allow noisy signals over or near differential serial wires.  
Example: No CMOS traces over differential serial wires.
- Use only one ground plane or wire over the differential serial wires. Do not run ground over top and bottom.
- Design goal of 100-ohms differential characteristic impedance.
- Do not place test points on differential serial wires.
- Use differential serial wires a minimum of 2cm away from the antenna.
- Visit Fairchild's website at <http://www.fairchildsemi.com/products/interface/userdes.html>, contact your sales rep, or contact Fairchild directly at [interface@fairchildsemi.com](mailto:interface@fairchildsemi.com) for applications notes or flex guidelines.

## Absolute Maximum Ratings

Stresses exceeding the absolute maximum ratings may damage the device. The device may not function or be operable above the recommended operating conditions and stressing the parts to these levels is not recommended. In addition, extended exposure to stresses above the recommended operating conditions may affect device reliability. The absolute maximum ratings are stress ratings only.

Symbol	Parameter	Min.	Max.	Unit
V <sub>DD</sub>	Supply Voltage	-0.5	+3.6	V
	All Input/Output Voltage	-0.5	V <sub>DDP</sub> +0.5	V
T <sub>STG</sub>	Storage Temperature Range	-65	150	°C
T <sub>J</sub>	Maximum Junction Temperature		+150	°C
T <sub>L</sub>	Lead Temperature (Soldering, 4 Seconds)		+260	°C
ESD	IEC 61000 Board Level		15	kV
	Human Body Model, JESD22-A114, Serial I/O, /RES, PAR/SPI Pins		14	kV
	Human Body Model, JESD22-A114, All Other Pins		7.5	kV

## Recommended Operating Conditions

The Recommended Operating Conditions table defines the conditions for actual device operation. Recommended operating conditions are specified to ensure optimal performance to the datasheet specifications. Fairchild does not recommend exceeding them or designing to absolute maximum ratings.

Symbol	Parameter	Min.	Max.	Unit
V <sub>DDA</sub> , V <sub>DDS</sub> <sup>(3)</sup>	Supply Voltage	2.5	3.0	V
V <sub>DDP</sub>	Supply Voltage	1.6	V <sub>DDA/S</sub>	V
T <sub>A</sub>	Operating Temperature	-30	+70	°C

**Note:**

- V<sub>DDA</sub> and V<sub>DDS</sub> supplies must be hardwired together to the same power supply. V<sub>DDP</sub> must be less than or equal to V<sub>DDA</sub>/V<sub>DDS</sub>.

## Electrical Specifications

Values valid for over supply voltage and operating temperature ranges unless otherwise specified.

Symbol	Parameter	Test Conditions	Min.	Typ.	Max.	Unit
<b>DC Parallel I/O and Serial Characteristics</b>						
V <sub>IH</sub>	Input High Voltage		0.7 x V <sub>DDP</sub>		V <sub>DDP</sub>	V
V <sub>IL</sub>	Input Low Voltage		GND		0.3 x V <sub>DDP</sub>	V
V <sub>OH</sub>	Output High Voltage	SLEW=0 I <sub>OH</sub> = -250µA	0.8 x V <sub>DDP</sub>			V
		SLEW=1 I <sub>OH</sub> = -1mA				
V <sub>OL</sub>	Output High Voltage	SLEW=0 I <sub>OL</sub> = 250µA			0.2 x V <sub>DDP</sub>	V
		SLEW=1 I <sub>OL</sub> = 1mA				
I <sub>IN</sub>	Input Current		-5		5	µA
V <sub>GO</sub>	Serial Input Voltage Ground Offset	Slave Relative to Master		0		V
Z	Serial Transmission Line Impedance		70	100	120	Ω
<b>Power Characteristics</b>						
I <sub>DYN_SER</sub>	Dynamic Current of Master Device	V <sub>DDA/S</sub> =2.75V, M/S=1, V <sub>DDP</sub> =1.8V, /STBY=1, /RES=1	5.44MHz		4	mA
			12.00MHz		7	
			15.00MHz		8	
I <sub>DYN_DES</sub>	Dynamic Current of Slave Device	V <sub>DDA/S</sub> =2.75V, M/S=0, V <sub>DDP</sub> =1.8V, /STBY=1, /RES=1, C <sub>L</sub> = 0pF	5.44MHz		5	mA
			12.00MHz		8	
			15.00MHz		10	
I <sub>BRST_M</sub>	Burst Standby Current of Master	V <sub>DDA/S</sub> =2.75V, V <sub>DDP</sub> =1.8V, M/S=1, /STBY=1, /RST=1, No STROBE Signal, C <sub>L</sub> =0pF			1.3	mA
I <sub>BRST_S</sub>	Burst Standby Current of Slave	V <sub>DDA/S</sub> =2.75V, V <sub>DDP</sub> =1.8V, M/S=0, /STBY=1, /RST=1, No STROBE Signal, C <sub>L</sub> =0pF			1.8	mA
I <sub>STBY</sub>	Standby Current	Serializer or Deserializer V <sub>DDA/S</sub> =V <sub>DDP</sub> =3.0V, /STBY=0, /RST=1			10	µA
I <sub>RES</sub>	Reset Current	Serializer or Deserializer V <sub>DDA/S</sub> =V <sub>DDP</sub> =3.0V, /RST=0			10	µA
<b>AC Operating Characteristics</b>						
f <sub>WSTRB0</sub>	Write Strobe Frequency	CKSEL=0 STRB0	0		8	MHz
f <sub>WSTRB1</sub>	Write Strobe Frequency	CKSEL=1 STRB1	0		15	MHz
f <sub>RSTRB</sub>	Read Strobe Frequency		0		2	MHz
t <sub>R</sub> , t <sub>F</sub>	Input Edge Rates <sup>(4)</sup>				40	ns
t <sub>S1</sub>	Write Mode Setup Time	DP before STRBn ↑, Figure 11	5			ns
t <sub>H1</sub>	Write Mode Hold Time	DP after STRBn ↑, Figure 11	15			ns
t <sub>S2</sub>	READ Mode Setup Time	R/W, CNTL before STRBn ↓, Figure 12	0			ns
t <sub>H2</sub>	READ Mode Hold Time	R/W, CNTL after STRBn ↓, Figure 12	16			ns
t <sub>S-STRB</sub>	CKSEL to STRBn Setup Time	CKSEL before active edge STRBn <sup>(5)</sup> , CKSEL before SPI /CS, SPI /CS before CKSEL, Figure 13, Figure 14	50			ns

Symbol	Parameter	Test Conditions	Min.	Typ.	Max.	Unit
<b>AC Deserializer Specifications</b>						
t <sub>RO</sub> , t <sub>F0</sub>	Output Edge Rates of WCLK0,WCLK1	SLEW=0, C <sub>L</sub> =5pF 20% to 80% <sup>(4)</sup>	8		17	ns
		SLEW=1, C <sub>L</sub> =5pF 20% to 80% <sup>(4)</sup>			10	
t <sub>R1</sub> , t <sub>F1</sub>	Output Edge Rates of R/W, DP[17:0] CNTL[5:0]	SLEW=0, C <sub>L</sub> =5pF 20% to 80% <sup>(4)</sup>	8		22	ns
		SLEW=1, C <sub>L</sub> =5pF 20% to 80% <sup>(4)</sup>			17	
t <sub>CS</sub>	CNTL[5:0],R/W to Falling Edge of WCLKn	M/S=0 <sup>(6)</sup> , C <sub>L</sub> =5pF 50% to 50% <sup>(4)</sup> Figure 15	0	4		ns
t <sub>PDV-WR0</sub>	DP, CNTL to WCLK0 ↑	PAR/SPI=1 <sup>(6)</sup> , Figure 15	50	60		ns
t <sub>PDV-WR1</sub>	DP, CNTL to WCLK1 ↑	PAR/SPI=1 <sup>(6)</sup> , Figure 15	18	24		ns
t <sub>PDV-RD</sub>	CNTL to WCLKn ↑	PAR/SPI=1 <sup>(6)</sup> , Figure 17	200	224		ns
t <sub>PDV-SPI</sub>	Data, CNTL to SCLK ↑	PAR/SPI=0 <sup>(6)</sup> , Figure 16	40	60		ns
t <sub>PWL-WR0</sub>	WCLK0 Pulse Width Low; Write Mode	M/S=0, R/W=0, PAR/SPI=1 <sup>(6,7)</sup> Figure 15	50	56		ns
t <sub>PWL-WR1</sub>	WCLK1 Pulse Width Low; Write Mode	M/S=0, R/W=0, PAR/SPI=1 <sup>(6,7)</sup> Figure 15	18	20		ns
t <sub>PWL-RD</sub>	Pulse Width Low of WCLK; Read Mode	M/S=0, R/W=1, PAR/SPI=1 <sup>(6,7)</sup> Figure 17	200	220		ns
t <sub>PWL-SPI</sub>	Pulse Width Low of WCLK; SPI Mode	M/S=0, R/W=0, PAR/SPI=0 <sup>(6,7)</sup> Figure 16	40	56		ns
<b>AC Data Latencies</b>						
t <sub>PD-WR0</sub>	Write Latency	WRITE Mode, CKSEL=0 <sup>(8,9,10)</sup> Figure 15		147		ns
t <sub>PD-WR1</sub>	Write Latency	WRITE Mode, CKSEL=1 <sup>(8,9,10)</sup> Figure 15		111		ns
t <sub>PD-RD</sub>	Total Read Latency	READ Mode <sup>(8,10,11)</sup> Figure 17		340	480	ns
t <sub>PD-RDC</sub>	Read Control Latency	READ Mode <sup>(8,10,12)</sup> Figure 17		276		ns
t <sub>PD-RDD</sub>	Read Data Latency	READ Mode <sup>(8,10,13)</sup> Figure 17		84		ns
t <sub>PD-SPI</sub>	SPI Write Latency	SPI-WRITE Mode <sup>(8,10,14)</sup> Figure 16		115		ns
<b>AC Oscillator Specifications</b>						
f <sub>OSC</sub>	Serial Operating Frequency		240	275	310	MHz
t <sub>OSC-STBY</sub>	Oscillator Stabilization Time After Standby	V <sub>DDA</sub> =V <sub>DDSD</sub> =2.75V /RES=1, /STBY ↑ Transition		15	30	µs
t <sub>OSC-RES</sub>	Oscillator Stabilization Time After Reset	V <sub>DDA</sub> =V <sub>DDSD</sub> =2.75V /STBY=1, /RES ↑ Transition		30	50	µs
<b>AC Reset and Standby Timing</b>						
t <sub>VDD-OFF</sub>	Power Down Relative to /RES <sup>(15)</sup>	Figure 19	20			µs
t <sub>STRB-RES</sub>	/RES after last STRBn ↑	M/S=0 or 1, /STBY=1, R/W=0 <sup>(16)</sup> Figure 19	0			ns
t <sub>STRB-STBY</sub>	Standby time after last strobe	M/S=0 or 1, /STBY=1 <sup>(17)</sup> Figure 19	200			ns
t <sub>RES-OFF</sub>	Master/Slave Reset Disable Time	M/S=1 /STBY=1, /RES=↓ Figure 19		15	20	µs

Symbol	Parameter	Test Conditions	Min.	Typ.	Max.	Unit
$t_{VDD-SKEW}$	Allowed Skew between $V_{DDP}$ and $V_{DDA/S}$ <sup>(18)</sup>	Figure 18	$-\infty$		$+\infty$	ms
$t_{VDD-RES}$	Minimum Reset Low Time After $V_{DD}$ Stable	M/S=0 /STBY=1, /RES= $\uparrow$ <sup>(19)</sup> Figure 18	20			$\mu$ s
$t_{RES-STBY}$	/STBY Wait Time After /RES $\uparrow$	M/S=1 /RES=1, /STBY= $\uparrow$ Figure 18	20			$\mu$ s
$t_{DVALID}$	/STBY to Active Edge of Strobe	M/S=0 /RES=1 <sup>(20)</sup> Figure 18	30			$\mu$ s

**Notes:**

4. Characterized, but not production tested.
5. Active edge of strobe is the rising edge for a write transaction and the falling edge for a read transaction.
6. Indirectly tested through serial clock frequency and serial data bit tests.
7. Pulse width low WCLKn measurements are measured at 30% of  $V_{DDP}$ . Measurements apply when SLEW=0 or SLEW=1.
8. Minimum times occur with maximum oscillator frequency. Maximum times occur with minimum oscillator frequency.
9. Write latency is the sum of the delay through the master serializer and slave deserializer, plus the flight time across the flex cable and I/O propagation delays.
10. Assumes propagation delay across the flex cable and through the I/Os of 20ns.
11. Total read latency  $t_{PD-RD}$  is the sum of the Read-Control Phase latency ( $t_{PD-RDC}$ ) and the Read-Data Phase latency ( $t_{PD-RDD}$ ).  $t_{PD-RD} = t_{PD-RDC} + t_{PD-RDD}$ .
12. Read-Control latency is the sum of the delay through the master serializer and slave deserializer, plus flex cable flight times and I/O propagation delays.
13. Read Data latency is the sum of the delay through the slave serializer and master deserializer, plus flex cable flight times and I/O propagation delays.
14. SPI-Write latency is the sum of the delay through the master serializer and slave deserializer, plus the flight time across the flex cable and I/O propagation delays.
15. Timing allows the device to completely reset prior to powering down.
16. Internal reset filter allows assertion prior to completion of read or write data transfer.
17. Timing ensures that last write transaction is complete prior to going into standby.
18.  $V_{DDA/S}$  must power up together.  $V_{DDP}$  may power-up relative to  $V_{DDA/S}$  in any order without static power being consumed. Guaranteed by characterization.
19. /RES signal should be held low for minimum time specified after supplies go HIGH. It is recommended that /RES be held low during the power supply ramp.
20. STRBn must be held off until internal oscillator has stabilized.

## Typical Performance Characteristics

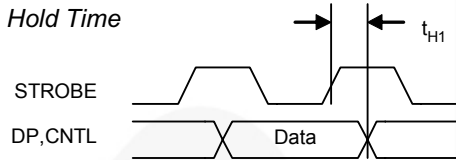
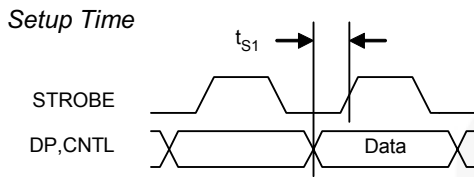

Setup: CKSEL=0 or 1, R/W=0

**Figure 11. Master Write Setup and Hold Time**

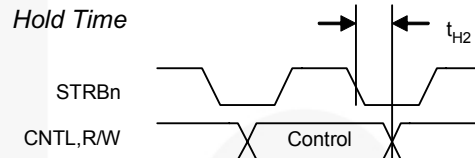
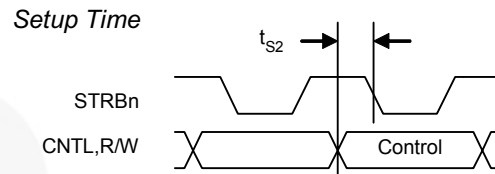

Setup: CKSEL=0 or 1, R/W=1

**Figure 12. Master Read Setup and Hold Time**

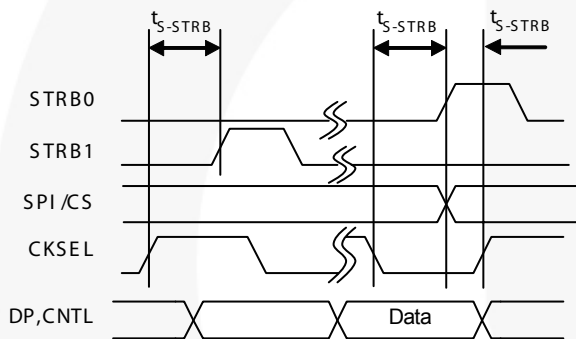

Setup: CKSEL=0 or 1, R/W=0

**Figure 13. CKSEL Write Setup Time**

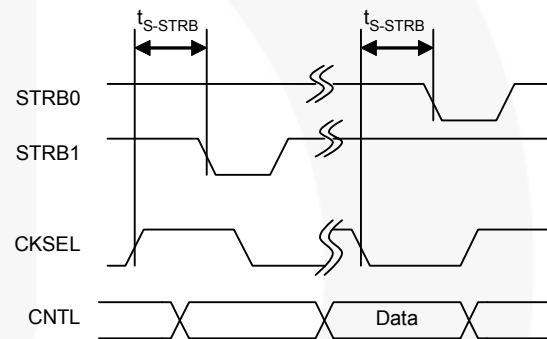

Setup: CKSEL=0 or 1, R/W=1

**Figure 14. CKSEL Read Setup Time**

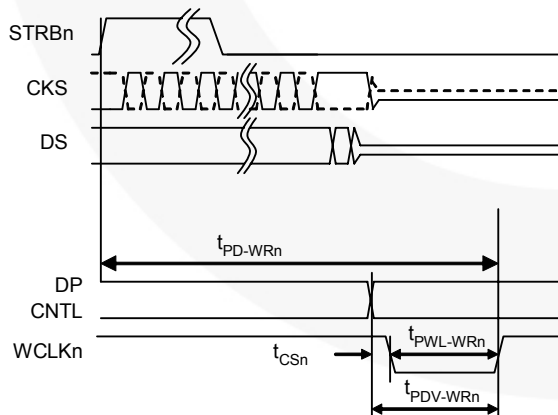

Setup: CKSEL=0 or 1, R/W=0, PAR/SPI=1

**Figure 15. Slave Write Mode Timing**

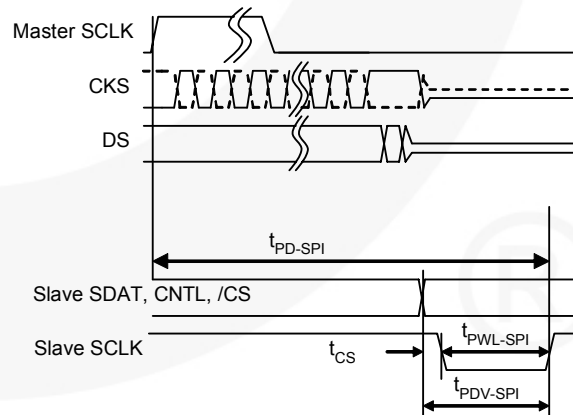

Setup: CKSEL=0, R/W=0, PAR/SPI=0, /CS=0

**Figure 16. Slave SPI Mode Timing**

### Typical Performance Characteristics (Continued)

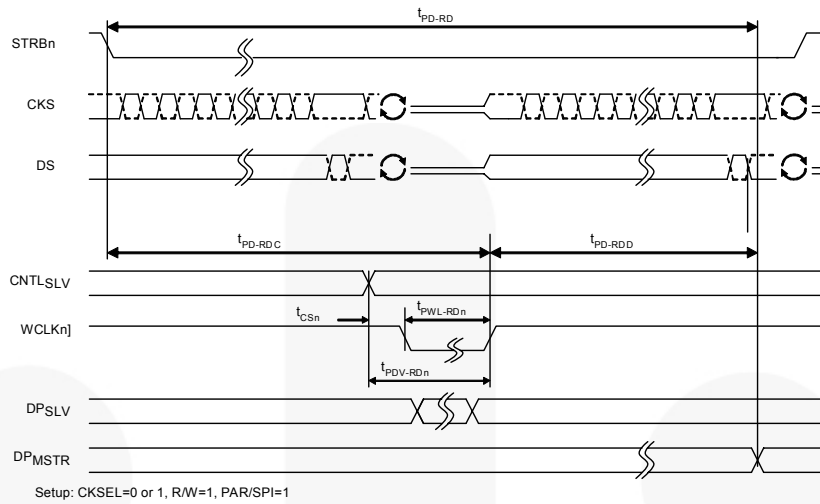

**Figure 17. Slave Read Mode Timing**

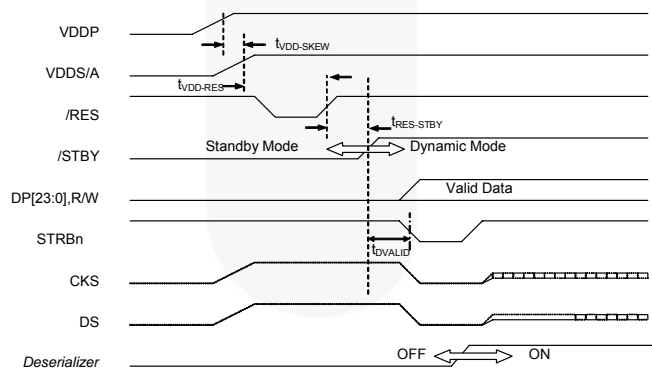

**Figure 18. Power-Up Timing**

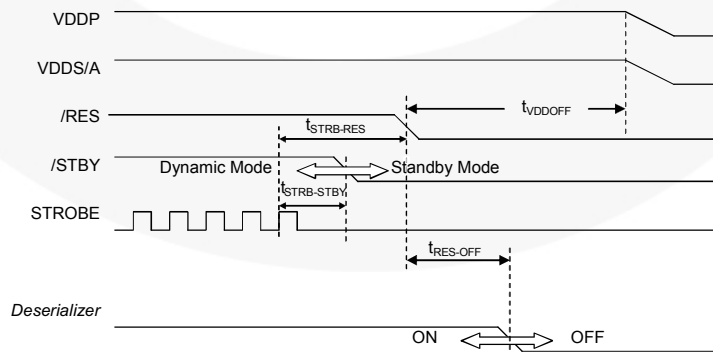

**Figure 19. Power-Down Timing**



Physical Dimensions

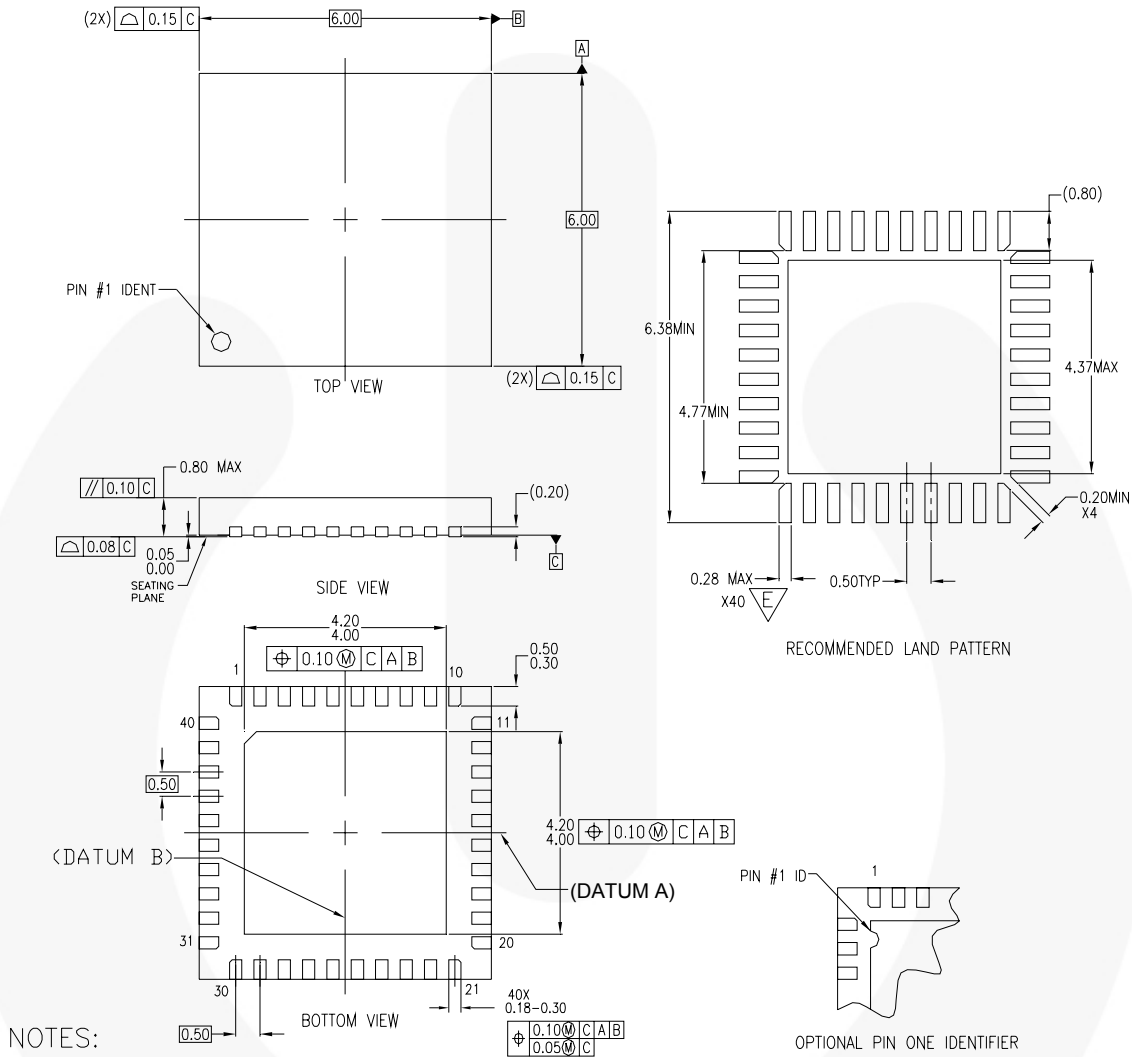

NOTES:

- A. CONFORMS TO JEDEC REGISTRATION MO-220, VARIATION WJJD-2 WITH EXCEPTION THIS IS A SAWN VERSION.
- B. DIMENSIONS ARE IN MILLIMETERS.
- C. DIMENSIONS AND TOLERANCES PER ASME Y14.5M, 1994
- D. LAND PATTERN PER IPC SM-782 FABRICATION AND ASSEMBLY TOLERANCES OF 0.1 MM APPLIED
- E. WIDTH REDUCED TO AVOID SOLDER BRIDGING.
- G. DIMENSIONS ARE NOT INCLUSIVE OF BURRS, MOLD FLASH, NOR TIE BAR PROTRUSIONS.

MLP40Arev2

Figure 20. 40-Lead, Molded Leadless Package (MLP)

**Physical Dimensions** (Continued)

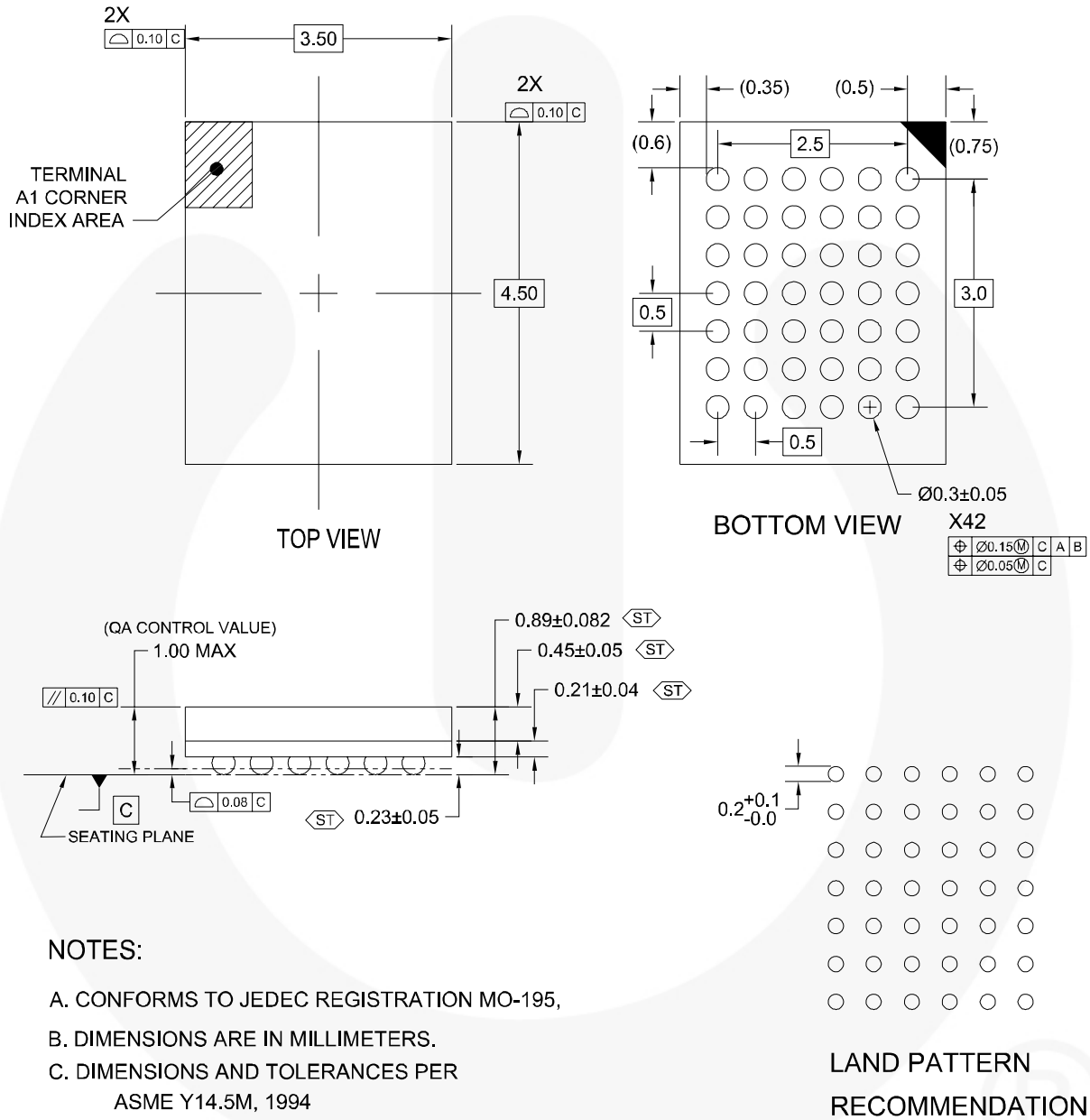

**NOTES:**

- A. CONFORMS TO JEDEC REGISTRATION MO-195,
- B. DIMENSIONS ARE IN MILLIMETERS.
- C. DIMENSIONS AND TOLERANCES PER ASME Y14.5M, 1994
- D. STATISTICAL TOLERANCING FOR REFERENCE REFER TO MAX DIMENSION FOR QA INSPECTION
- E. LAND PATTERN RECOMENDATION PER IPC-7351 TABLE 14-15 LAND PATTERN NAME PER TABLE 3-15: BGA50P+6X7-42

BGA42ArevB

**Figure 21. 42-Ball, Ball Grid Array (BGA) Package**



## TRADEMARKS

The following are registered and unregistered trademarks and service marks Fairchild Semiconductor owns or is authorized to use and is not intended to be an exhaustive list of all such trademarks.

ACEX <sup>®</sup>	Green FPS <sup>™</sup>	Power247 <sup>®</sup>	SuperSOT <sup>™</sup> -8
Build it Now <sup>™</sup>	Green FPS <sup>™</sup> e-Series <sup>™</sup>	POWEREDGE <sup>®</sup>	SyncFET <sup>™</sup>
CorePLUS <sup>™</sup>	GTO <sup>™</sup>	Power-SPM <sup>™</sup>	The Power Franchise <sup>®</sup>
CROSSVOLT <sup>™</sup>	i-Lo <sup>™</sup>	PowerTrench <sup>®</sup>	<b>the power franchise</b>
CTL <sup>™</sup>	IntelliMAX <sup>™</sup>	Programmable Active Droop <sup>™</sup>	TinyBoost <sup>™</sup>
Current Transfer Logic <sup>™</sup>	ISOPLANAR <sup>™</sup>	QFET <sup>®</sup>	TinyBuck <sup>™</sup>
EcoSPARK <sup>®</sup>	MegaBuck <sup>™</sup>	QS <sup>™</sup>	TinyLogic <sup>®</sup>
<b>F</b> <sup>®</sup>	MICROCOUPLER <sup>™</sup>	QT Optoelectronics <sup>™</sup>	TINYOPTO <sup>™</sup>
Fairchild <sup>®</sup>	MicroFET <sup>™</sup>	Quiet Series <sup>™</sup>	TinyPower <sup>™</sup>
Fairchild Semiconductor <sup>®</sup>	MicroPak <sup>™</sup>	RapidConfigure <sup>™</sup>	TinyPWM <sup>™</sup>
FACT Quiet Series <sup>™</sup>	MillerDrive <sup>™</sup>	SMART START <sup>™</sup>	TinyWire <sup>™</sup>
FACT <sup>®</sup>	Motion-SPM <sup>™</sup>	SPM <sup>®</sup>	μSerDes <sup>™</sup>
FAST <sup>®</sup>	OPTOLOGIC <sup>®</sup>	STEALTH <sup>™</sup>	UHC <sup>®</sup>
FastvCore <sup>™</sup>	OPTOPLANAR <sup>®</sup>	SuperFET <sup>™</sup>	UniFET <sup>™</sup>
FPS <sup>™</sup>	 <sup>®</sup>	SuperSOT <sup>™</sup> -3	VCX <sup>™</sup>
FRFET <sup>®</sup>	PDP-SPM <sup>™</sup>	SuperSOT <sup>™</sup> -6	
Global Power Resource <sup>SM</sup>	Power220 <sup>®</sup>		

## DISCLAIMER

FAIRCHILD SEMICONDUCTOR RESERVES THE RIGHT TO MAKE CHANGES WITHOUT FURTHER NOTICE TO ANY PRODUCTS HEREIN TO IMPROVE RELIABILITY, FUNCTION, OR DESIGN. FAIRCHILD DOES NOT ASSUME ANY LIABILITY ARISING OUT OF THE APPLICATION OR USE OF ANY PRODUCT OR CIRCUIT DESCRIBED HEREIN; NEITHER DOES IT CONVEY ANY LICENSE UNDER ITS PATENT RIGHTS, NOR THE RIGHTS OF OTHERS. THESE SPECIFICATIONS DO NOT EXPAND THE TERMS OF FAIRCHILD'S WORLDWIDE TERMS AND CONDITIONS, SPECIFICALLY THE WARRANTY THEREIN, WHICH COVERS THESE PRODUCTS.

## LIFE SUPPORT POLICY

FAIRCHILD'S PRODUCTS ARE NOT AUTHORIZED FOR USE AS CRITICAL COMPONENTS IN LIFE SUPPORT DEVICES OR SYSTEMS WITHOUT THE EXPRESS WRITTEN APPROVAL OF FAIRCHILD SEMICONDUCTOR CORPORATION.

As used herein:

1. Life support devices or systems are devices or systems which, (a) are intended for surgical implant into the body or (b) support or sustain life, and (c) whose failure to perform when properly used in accordance with instructions for use provided in the labeling, can be reasonably expected to result in a significant injury of the user.
2. A critical component in any component of a life support device, or system whose failure to perform can be reasonably expected to cause the failure of the life support device or system, or to affect its safety or effectiveness.

## PRODUCT STATUS DEFINITIONS

### Definition of Terms

Datasheet Identification	Product Status	Definition
Advance Information	Formative or In Design	This datasheet contains the design specifications for product development. Specifications may change in any manner without notice.
Preliminary	First Production	This datasheet contains preliminary data; supplementary data will be published at a later date. Fairchild Semiconductor reserves the right to make changes at any time without notice to improve design.
No Identification Needed	Full Production	This datasheet contains final specifications. Fairchild Semiconductor reserves the right to make changes at any time without notice to improve design.
Obsolete	Not In Production	This datasheet contains specifications on a product that has been discontinued by Fairchild Semiconductor. The datasheet is printed for reference information only.

Rev. 131