

User Guide for  
**FEBFAN9611\_S388V1**  
**FAN9611 400-W Interleaved  
Dual-BCM PFC Controller  
Evaluation Board**

Featured Fairchild Products: FAN9611

***Direct questions or comments  
about this evaluation board to:  
“Worldwide Direct Support”***

***[Fairchild Semiconductor.com](http://Fairchild Semiconductor.com)***

***Please contact a local Fairchild Sales representative  
for an evaluation board.***

## Table of Contents

Table of Contents .....	2
1. Overview of the Evaluation Board .....	3
2. Key Features .....	5
3. Specifications .....	6
4. Test Procedure .....	7
5. Schematic .....	8
6. Boost Inductor Specification .....	9
7. Line Filter Inductor Specifications .....	10
8. PCB Layout .....	11
9. Bill of Materials (BOM) .....	15
10. Test Results .....	17
10.1. Startup .....	17
10.2. Normal Operation .....	19
10.3. Line Transient .....	21
10.4. Load Transient .....	22
10.5. Brownout Protection .....	23
10.6. Phase Management .....	25
10.7. Efficiency .....	28
10.8. Harmonic Distortion and Power Factor .....	29
11. References .....	31
12. Ordering Information .....	31
13. Revision History .....	31

The following user guide supports the FAN9611 400-W evaluation board for interleaved boundary-conduction-mode power-factor-corrected supply. It should be used in conjunction with the FAN9611 datasheet as well as the Fairchild application note [AN-6086 Design Considerations for Interleaved Boundary-Conduction Mode PFC Using FAN9611 / FAN9612](#). The evaluation board can be interchangeably used to evaluate either the FAN9611 (10 V turn-on threshold) or FAN9612 controller (12.5 V turn-on threshold). Please visit Fairchild's website at [www.fairchildsemi.com](http://www.fairchildsemi.com) for additional information. This Evaluation board can be identified by the top side silkscreen marking "FAN9612 400W INTERLEAVED PFC CONVERTER" and "FEB388".

## 1. Overview of the Evaluation Board

The FAN9611 interleaved dual Boundary-Conduction-Mode (BCM) Power-Factor-Correction (PFC) controllers operate two parallel-connected boost power trains 180° out of phase. Interleaving extends the maximum practical power level of the control technique from about 300 W to greater than 800 W. Unlike the continuous conduction mode (CCM) technique often used at higher power levels, BCM offers inherent zero-current switching of the boost diodes (no reverse-recovery losses), which permits the use of less expensive diodes without sacrificing efficiency. Furthermore, the input and output filters can be smaller due to ripple current cancellation between the power trains and doubling of effective switching frequency.

The advanced line feedforward with peak detection circuit minimizes the output voltage variation during line transients. To guarantee stable operation with less switching loss at light load, the maximum switching frequency is clamped at 525 kHz. Synchronization is maintained under all operating conditions.

Protection functions include output over-voltage, over-current, open-feedback, under-voltage lockout, brownout, and redundant latching over-voltage protection. The FAN9611 is available in a lead-free 16-lead SOIC package.

This FAN9611 evaluation board is a four-layer board designed for 400 W (400 V / 1 A) rated power. Thanks to the phase management, the efficiency is maintained above 96% at low-line and high-line, even down to 10% of the rated output power. Efficiency is 96.4% at line voltage 115 V<sub>AC</sub> and 98.2% at 230 V<sub>AC</sub> under full-load conditions.

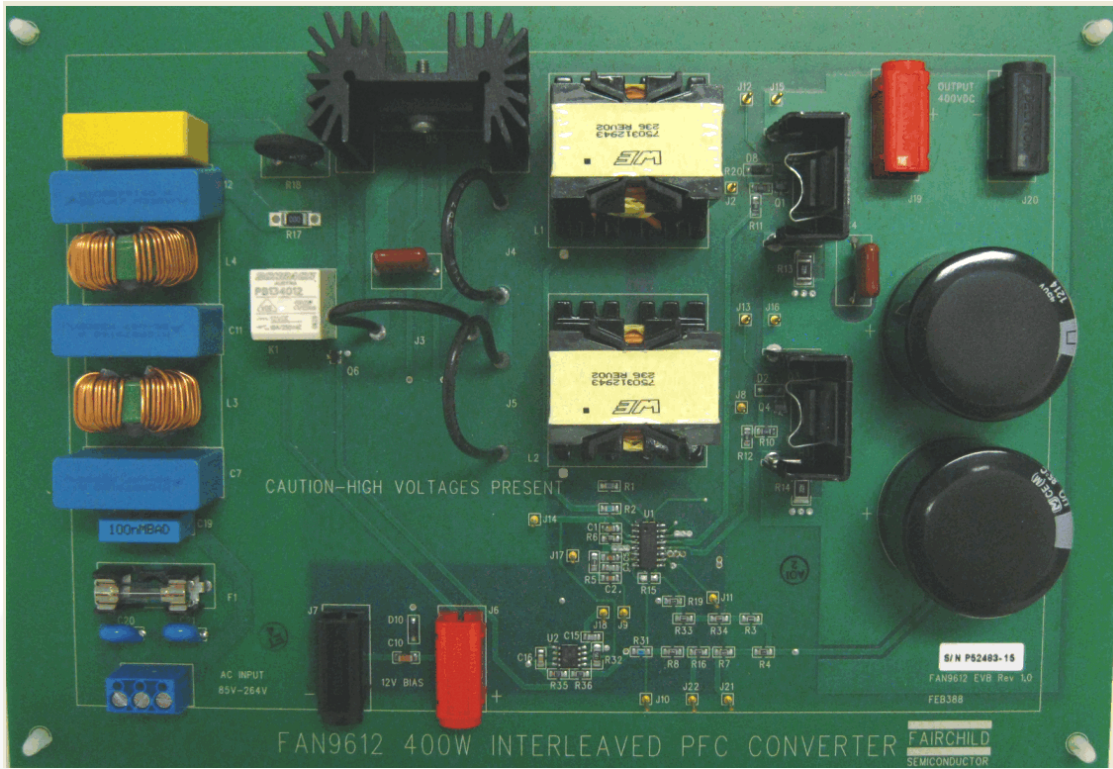

Figure 1. Top View

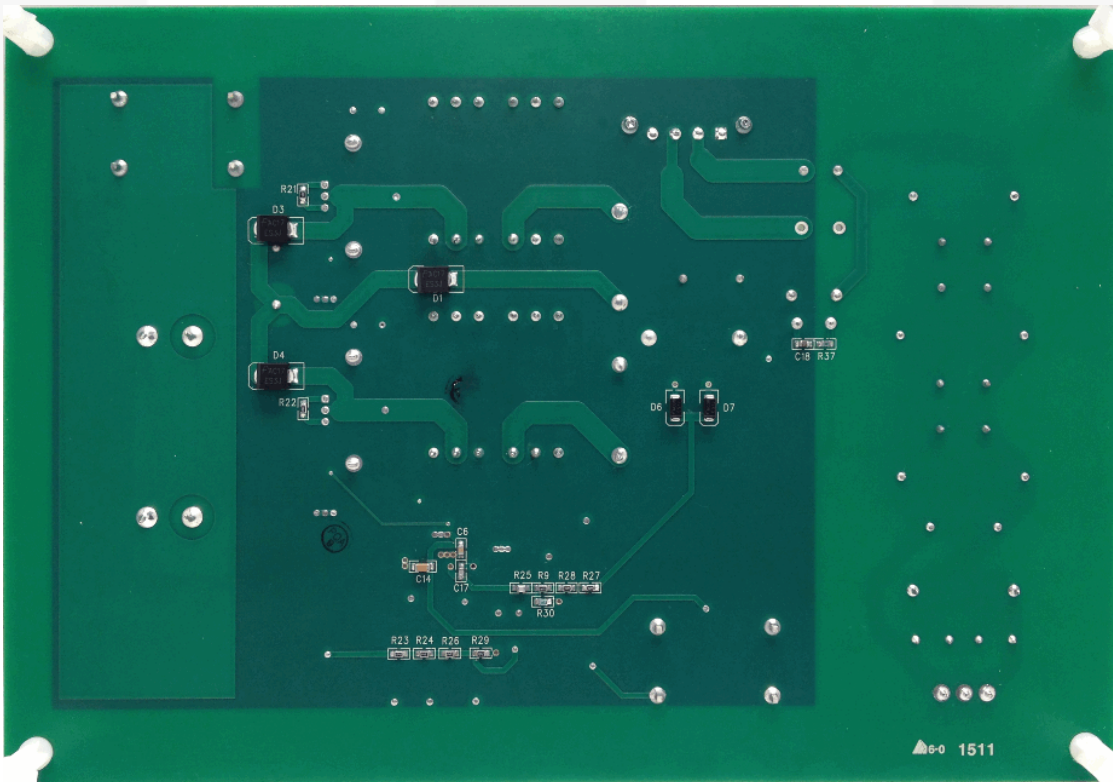

Figure 2. Bottom View

## 2. Key Features

- Low Total Harmonic Distortion, High Power Factor
- 180° Out-of-Phase Synchronization
- Automatic Phase Disable at Light Load
- 1.8-A Sink, 1.0-A Source, High-Current Gate Drivers
- Transconductance ( $g_M$ ) Error Amplifier for Reduced Overshoot
- Voltage-Mode Control with  $(V_{IN})^2$  Feed-forward
- Closed-Loop Soft-Start with Programmable Soft-Start Time for Reduced Overshoot
- Minimum Restart Timer Frequency to Avoid Audible Noise
- Maximum Switching Frequency Clamp
- Brownout Protection with Soft Recovery
- Non-Latching OVP on FB Pin and Second-Level Latching Protection on OVP Pin
- Open-Feedback Protection
- Over-Current and Power-Limit Protection for Each Phase
- Low Startup Current: 80  $\mu$ A Typical
- Works with DC Input Voltage and 50-Hz to 400-Hz AC Inputs

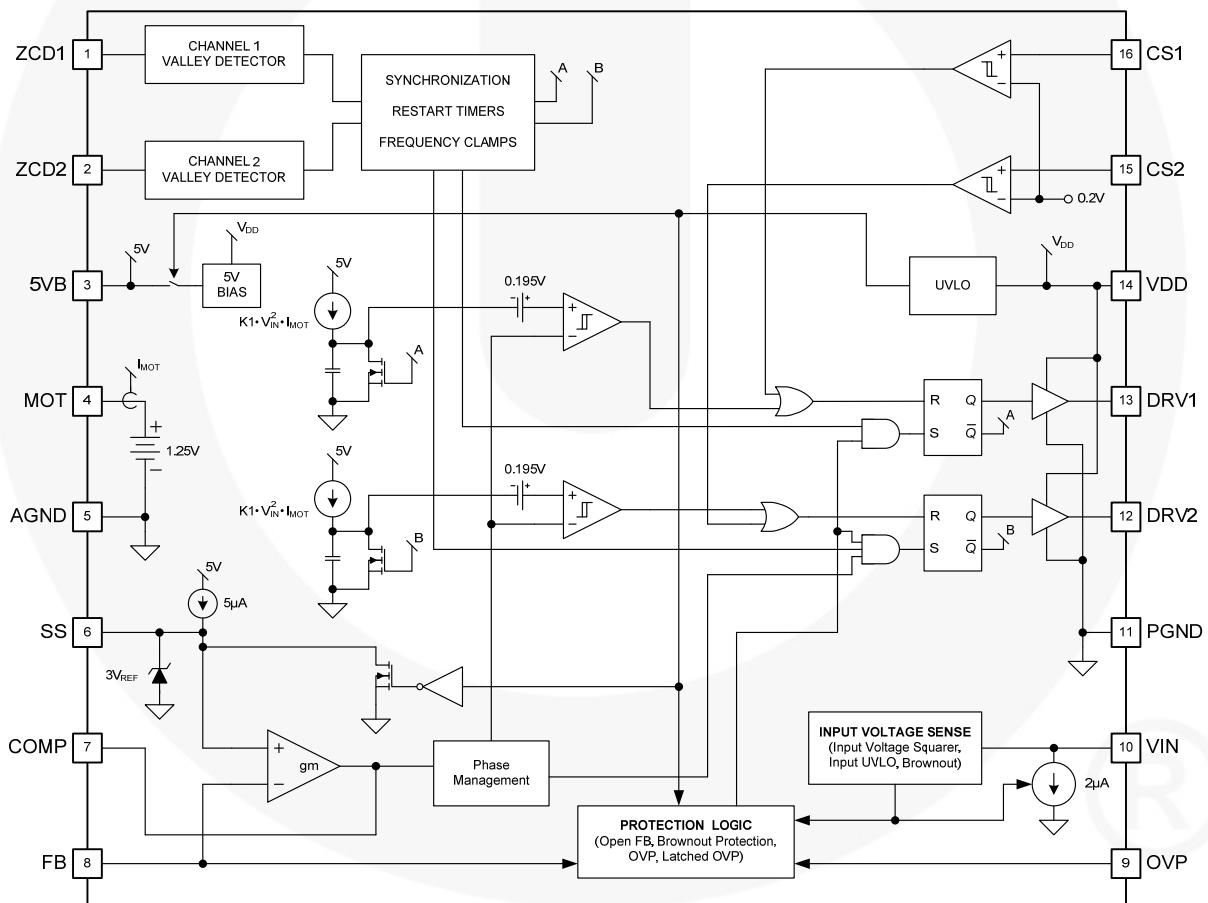

Figure 3. Block Diagram

### 3. Specifications

This board has been designed and optimized for the following conditions:

Input Voltage Range	Rated Output Power	Output Voltage (Rated Current)
$V_{IN}$ Nominal : 85~264 V <sub>AC</sub> $V_{DD}$ Supply : 13 V <sub>DC</sub> ~18 V <sub>DC</sub>	400 W	400 V - 1 A

**Note:**

1. Minimum output voltage during the 20 ms hold-up time is 330 V<sub>DC</sub>.

- $V_{LINE} = 85\sim 264$  V<sub>AC</sub>
- $V_{OUT} = 400$  V
- $f_{SW} > 50$  kHz
- Efficiency > 96% down to 20% load (115 V<sub>AC</sub>)
- Efficiency > 97% down to 20% load (230 V<sub>AC</sub>)
- PF > 0.99 at full load

The trip points for the built-in protections are set as below in the evaluation board.

- The non-latching output OVP trip point is set at 108% of the nominal output voltage.
- The latching output OVP trip point is set at 117% of the nominal output voltage.
- The line UVLO (brownout protection) trip point is set at 68 V<sub>AC</sub> (10 V<sub>AC</sub> hysteresis).
- The pulse-by-pulse current limit for each MOSFET is set at 9.1 A.

The maximum power limit is set at ~120% of the rated output power. The phase management function permits phase shedding/adding ~15% of the nominal output power for high line (230 V<sub>AC</sub>). This level can be programmed by modifying MOT resistor (R6).

## 4. Test Procedure

Before testing the board; DC voltage supply for  $V_{DD}$ , AC voltage supply for line input, and DC electric load for output should be connected to the board properly.

1. Supply  $V_{DD}$  for the control chip first. It should be higher than 13 V (*refer to the specification for  $V_{DD}$  turn-on threshold voltage in Table 1*).

**Table 1. Specification Excerpt from FAN9611 Datasheet**

Symbol	Parameter	Conditions	Min.	Typ.	Max.	Unit
<b>Supply</b>						
$I_{STARTUP}$	Startup Supply Current	$V_{DD} = V_{ON} - 0.2\text{ V}$		80	110	$\mu\text{A}$
$I_{DD}$	Operating Current	Output Not Switching		3.7	5.2	mA
$I_{DD\_DYM}$	Dynamic Operating Current	$f_{SW} = 50\text{ kHz}; C_{LOAD} = 2\text{ nF}$		4	6	mA
$V_{ON}$	UVLO Start Threshold	$V_{DD}$ Increasing	9.5	10.0	10.5	V
$V_{OFF}$	UVLO Stop Threshold	$V_{DD}$ Decreasing	7.0	7.5	8.0	V
$V_{HYS}$	UVLO Hysteresis	$V_{ON} - V_{OFF}$		2.5		V

2. Connect the AC voltage (85~265  $V_{AC}$ ) to start the FAN9611 / 12 evaluation board. Since FAN9611 / 12 has brownout protection, any input voltages lower than operation range triggers the protection.
3. Change load current (0~1 A) and check the operation.

## 5. Schematic

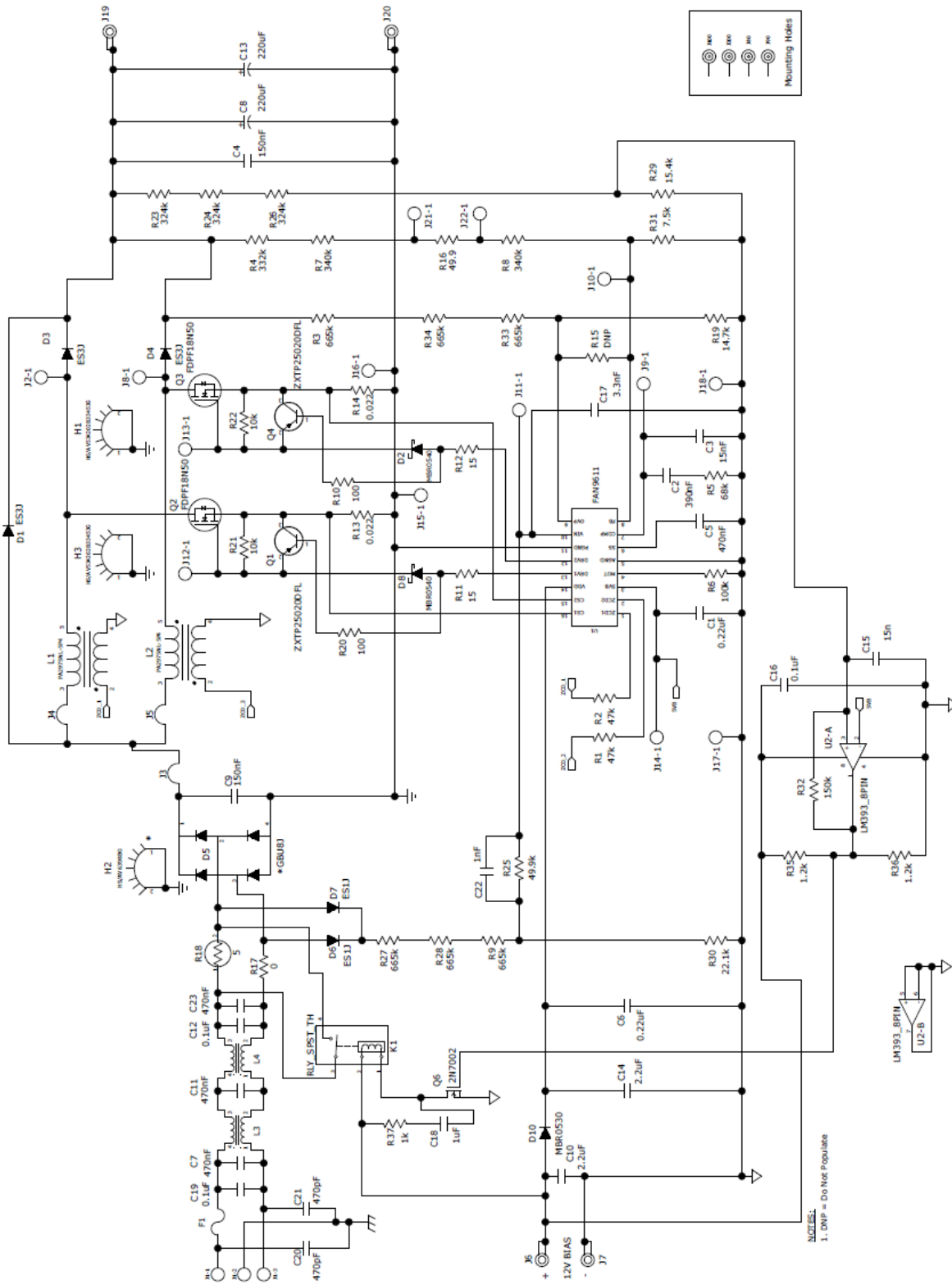

Figure 4. FAN9611 400-W Evaluation Board Schematic



## 6. Boost Inductor Specification

750312943 from Würth Electronics Midcom ([www.we-online.com/midcom](http://www.we-online.com/midcom))

OR

PA2975NL-5P4 from Pulse Electronics ([www.pulseelectronics.com](http://www.pulseelectronics.com))

- Core: PQ3230 ( $A_e=161 \text{ mm}^2$ )
- Bobbin: PQ3230
- Inductance : 200 H

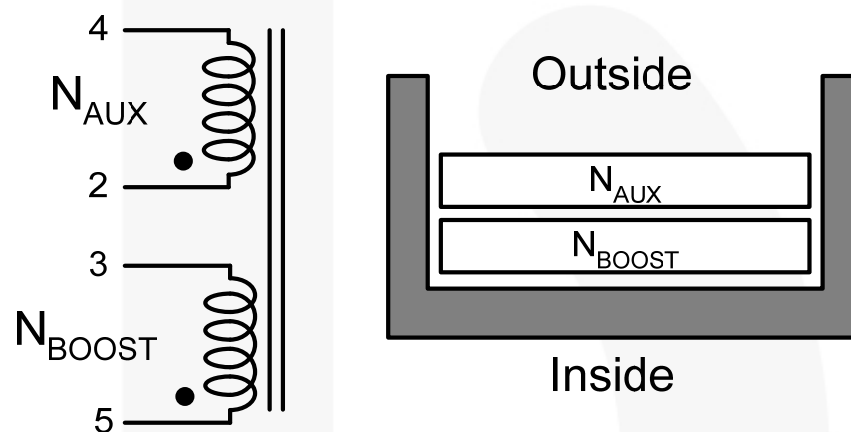
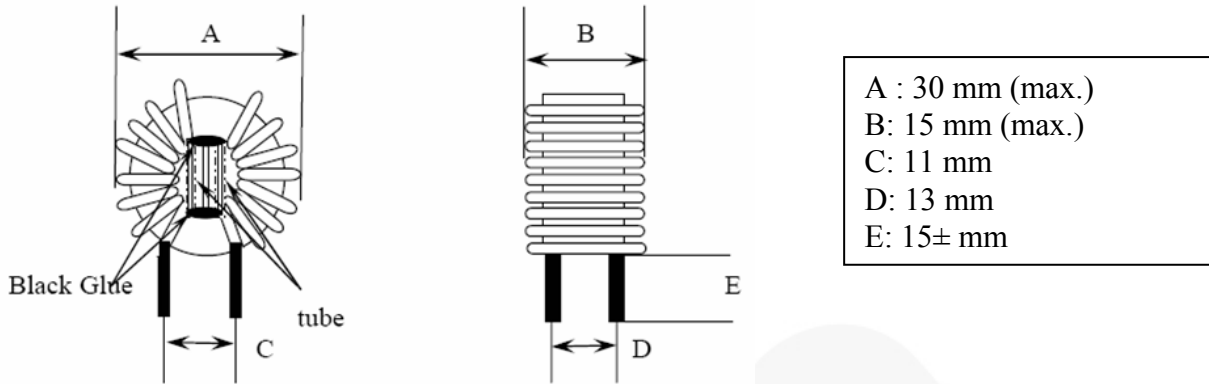

Figure 5. Boost Inductor used in this FAN9611 / 12 Evaluation Board

Table 2. Inductor Turns Specifications

	Pin	Turns
N1	5 → 3	30
Insulation Tape		
N2	2 → 4	3
Insulation Tape		

## 7. Line Filter Inductor Specifications



Electrical Specifications (1 kHz, 1 V)

- Inductance: 9.0 mH (min.) for each winding
- DC resistance: 0.05  $\Omega$  (max.) for each winding
- Number of turns: 0.9 mm $\times$ 2/30.5 turns for each winding

**Figure 6. Line Filter Inductor Specification**

**Table 3. Materials List**

Component	Material	Manufacturer	UL File Number
Core	T22x14x08	Core T22x14x08, TOMITA	
Wire	THFN-216	Ta Ya Electric Wire Co., Ltd.	E197768
	UEWN/U	PACIFIC Wire and cable Co., Ltd.	E201757
	UEWE	Tai-1 Electric Wire & Cable Co., Ltd.	E85640
	UWY	Jang Shing Wire Co., Ltd.	E174837
Solder	96.5%, Sn, 3%, Ag, 0.5% Cu	Xin Yuan Co., Ltd.	

## 8. PCB Layout

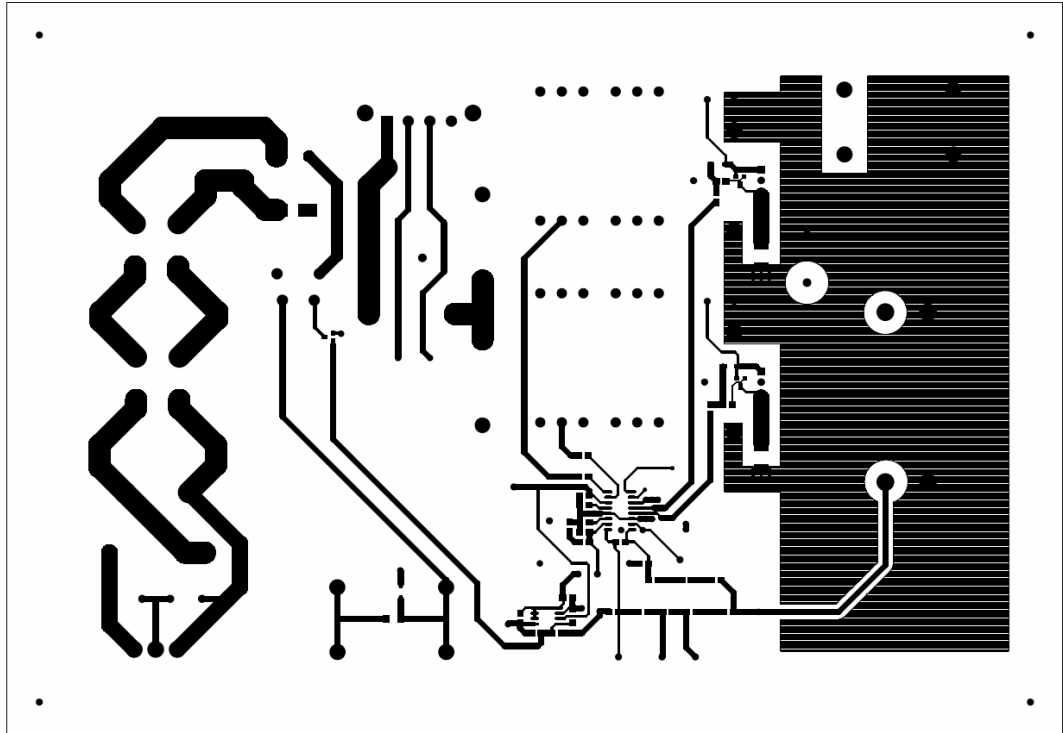

Figure 7. First Layer (Top Side)

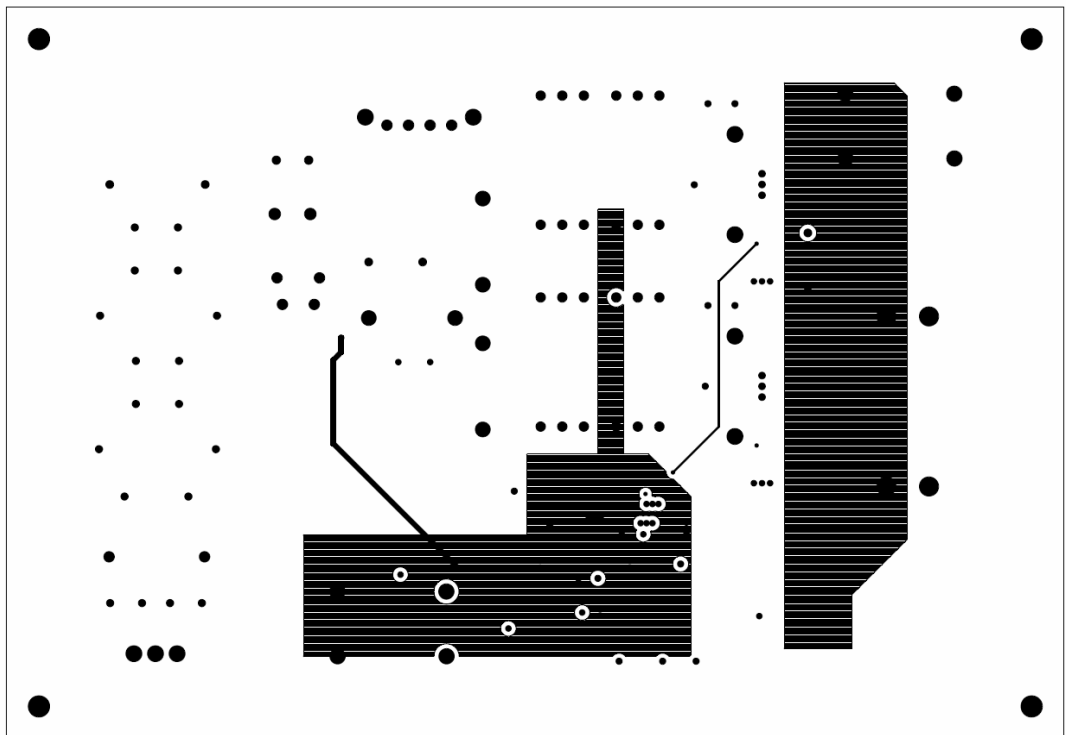

Figure 8. Second Layer (Plane Layer)

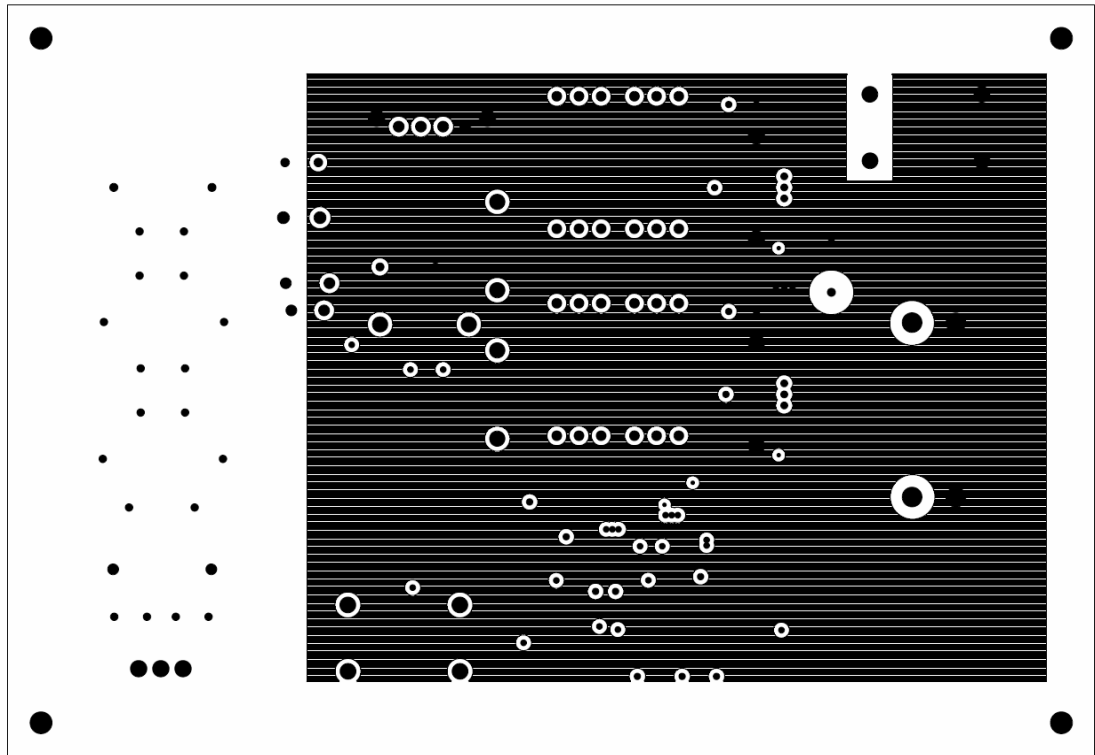

Figure 9. Third Layer (Ground Layer)

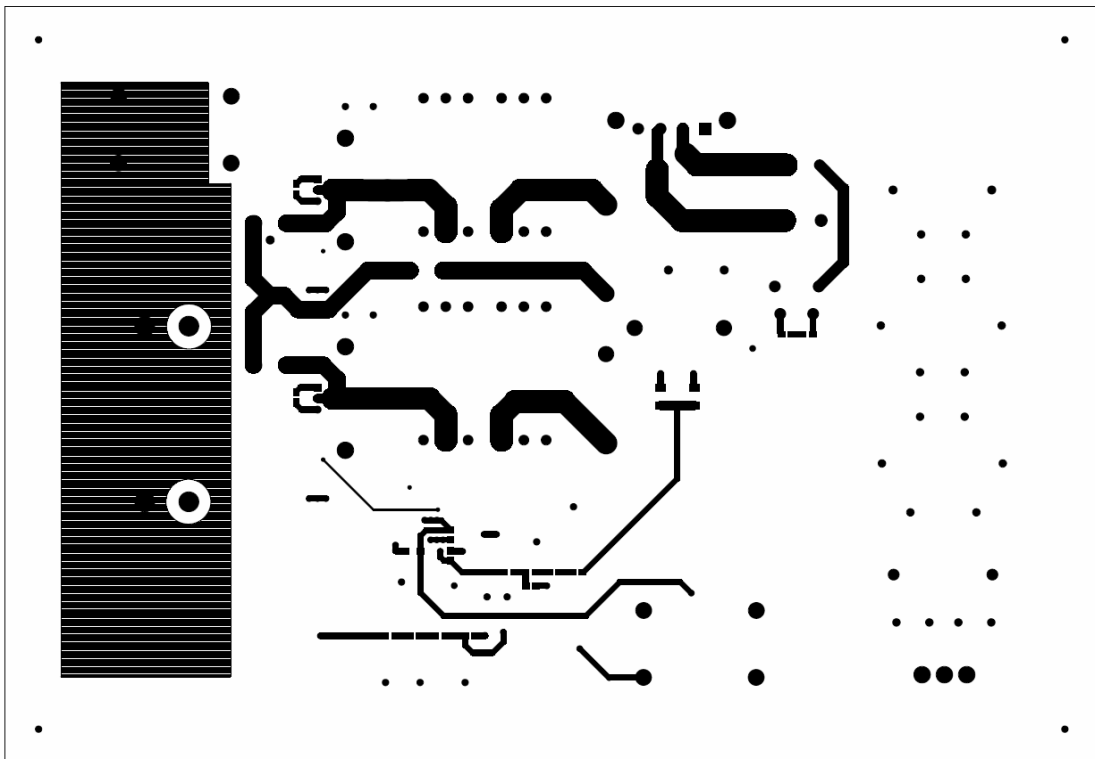

Figure 10. Fourth Layer (Bottom Side)

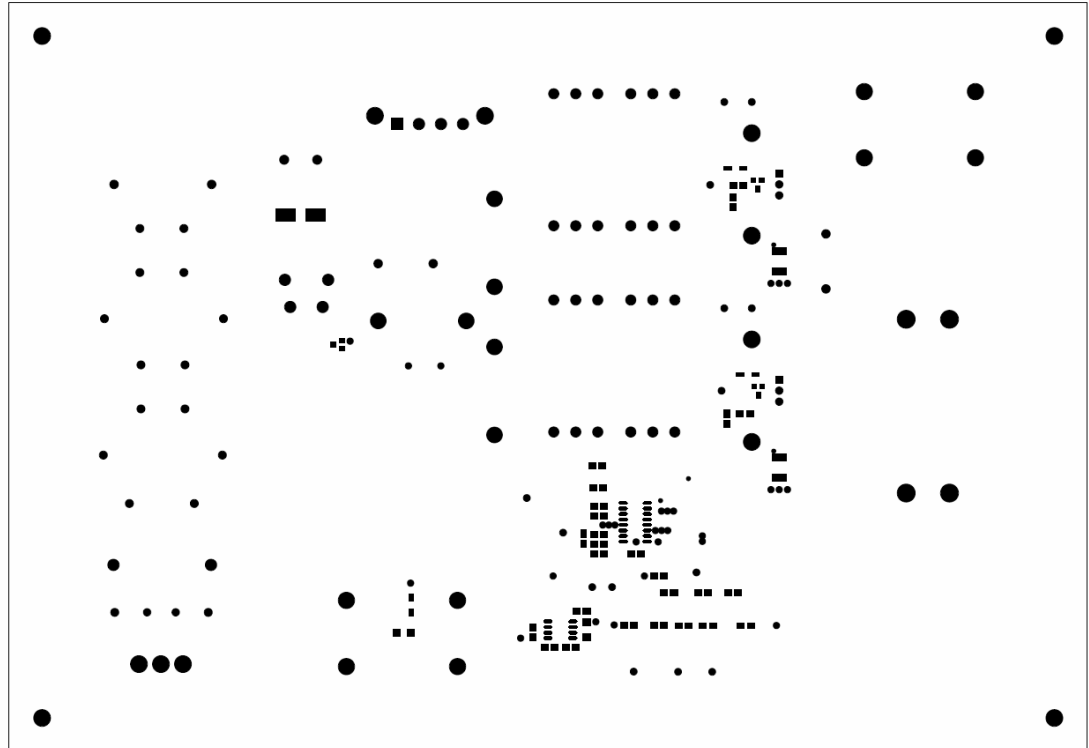

Figure 11. Top Solder Mask

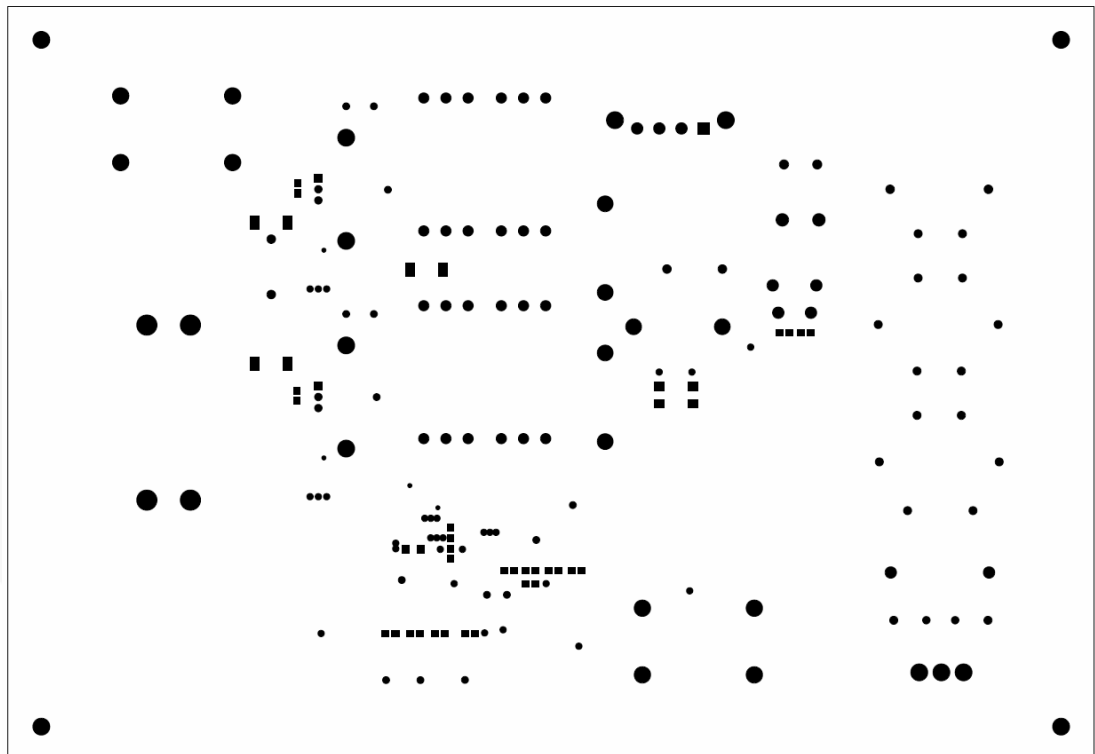
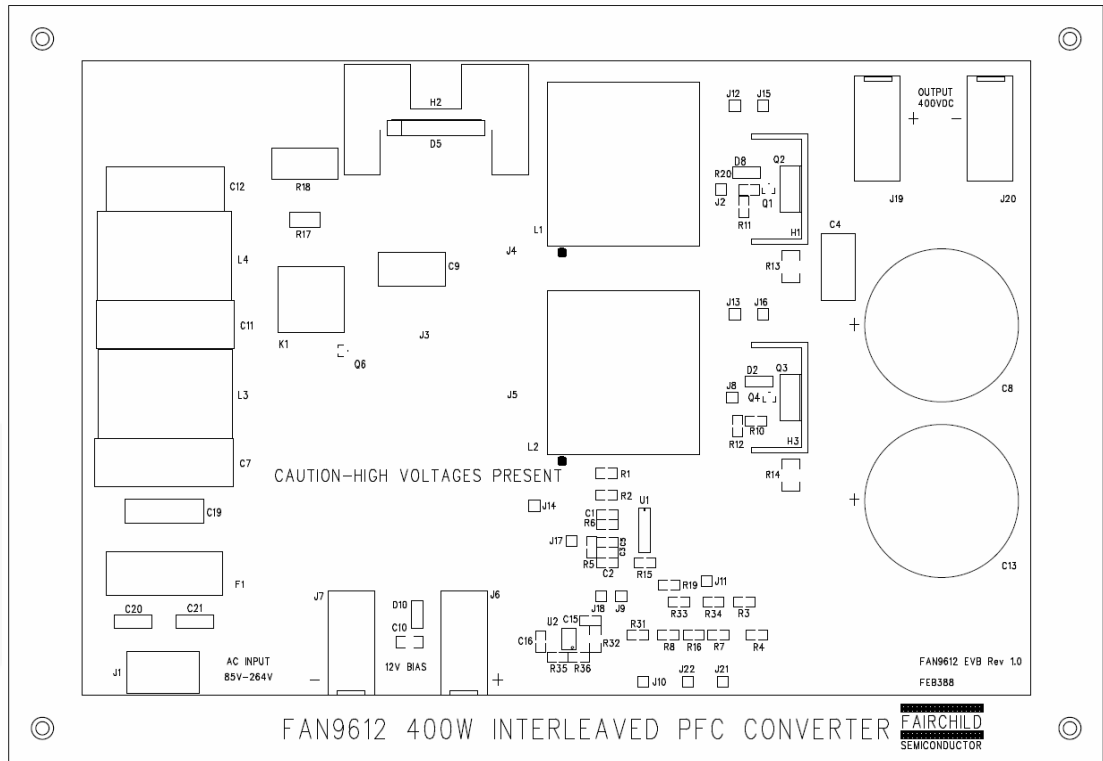
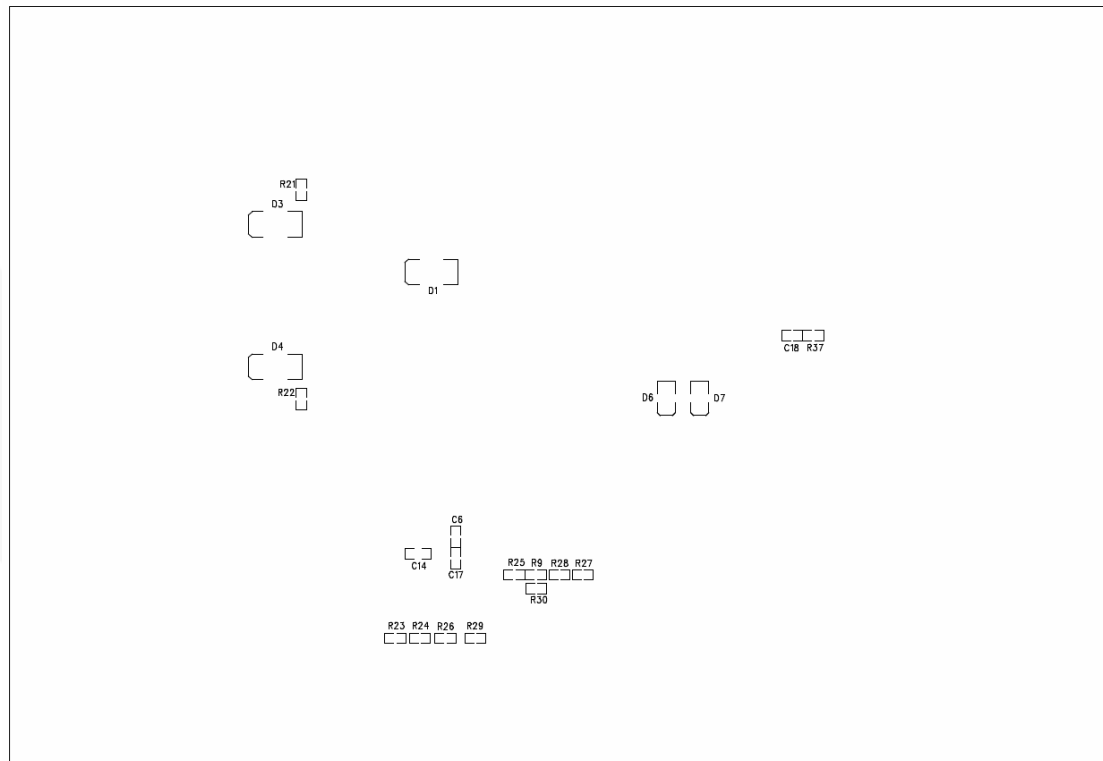

Figure 12. Bottom Solder Mask



**Figure 13. Top Silkscreen**



**Figure 14. Bottom Silkscreen**

## 9. Bill of Materials (BOM)

Qty.	Reference	Part Number	Value	Description	Package Type	Manufacturer
2	C1 C6		0.22 $\mu$ F	CAP, SMD, CERAMIC, 25 V, X7R	805	STD
1	C2		390 nF	CAP, SMD, CERAMIC, 25 V, X7R	805	STD
2	C4 C9	ECWF2W154JAQ	150 nF	CAP, 400 V, 5%, POLYPROPYLENE	Radial, Thru-Hole	Panasonic-ECG
1	C5		470 nF	CAP, SMD, CERAMIC, 25 V, X7R	805	STD
2	C7 C11 C23	B32914A3474	470 nF, 330 V	CAP, 330 V <sub>AC</sub> , 10%, POLYPROPYLENE	Box, Thru-Hole	EPCOS
2	C8 C13	EETUQ2W221E	220 $\mu$ F	CAP, ALUM, ELECT.	Radial, Thru-Hole	Panasonic
2	C10 C14		2.2 $\mu$ F	CAP, SMD, CERAMIC, 25 V, X7R	1206	STD
1	C12	HQX104K275R2	0.1 $\mu$ F, 275 V	CAP, X SERIES, 250 V <sub>AC</sub> , 5%, POLYPROPYLENE	Box, Thru-Hole	Fuhjyyu Electronic Industrial Co.
1	C15		15 nF	CAP, SMD, CERAMIC, 25 V, X7R	805	STD
1	C16		0.1 $\mu$ F	CAP, SMD, CERAMIC, 25 V, X7R	805	STD
1	C18		1 $\mu$ F	CAP, SMD, CERAMIC, 50 V, X5R	805	STD
1	C19	PHE840MB 6100MB05R17	0.1 $\mu$ F	CAP, X TYPE, 275 V <sub>AC</sub> , 10%, POLYPROPYLENE	Box, Axial	KEMET
2	C20-21	CS85- B2GA471KYNS	470 pF	CAP, CERAMIC, 250 V <sub>AC</sub> , 10%, Y5P,	Disc, Thru-hole	TDK Corporation
1	C22		1 nF	CAP, SMD, CERAMIC, 25 V, X7R	805	STD
3	D1 D3-4	S3J		Diode, 600 V, 3 A, Std recovery	SMC	Fairchild Semiconductor
2	D2 D8	MBR0540		Diode, Schottky, 40 V, 500 mA	SOD-123	Fairchild Semiconductor
1	D5	GBU8J		Bridge Rectifier, 600 V, 8 A	Thru-Hole	Fairchild Semiconductor
2	D6-7	ES1J		DIODE FAST REC 1 A 600 V	SMA	Fairchild Semiconductor
1	D10	MBR0530		DIODE SCHOTTKY 30 V 500 mA SOD-123	SOD-123	Fairchild Semiconductor
1	F1	31.8201		Fuseholder, 5x20 mm, 250 V <sub>AC</sub> , 10 A	PCB mount, Thru-hole	Schurter Inc
2	H1 H3	534202B33453G		Heatsink, 13.4°C/W, TO-220 with Tab-Koolclip for Q2-3	1"x0.475"x1.18"	Aavid Thermalloy
1	H2	639BG		TO-220 Heat sink for D5, Bridge Rectifier	1.65"x1.5"	Aavid Thermalloy
1	J1	ED100/3DS		Terminal Block, 5 mm Vert., 3 Pos.	Thru-hole	On Shore Technology, Inc.
14	J2 J8-18 J21-22	3103-1-00-15-00-00-08-0		Probe-pin, Gold, 0.3" x 40mil dia., 31mil mounting length	Thru-Hole	Mill-Max
3	J3-5			Jumper wire, #16, Insulated, for current probe measurement	Thru-Hole	Custom
2	J6 J19	571-0500		Banana Jack, .175, Horizontal, Insulated_RED	Thru-Hole	Deltron
2	J7 J20	571-0100		Banana Jack, .175, Horizontal, Insulated_BLK	Thru-Hole	Deltron
2	L1-2	750312943 PA2975NL-5P4	200 $\mu$ H	Coupled Inductor, PQ3230, Pri-30T, Sec-3T	Thru-Hole	Wurth Midcom Pulse Electronics
2	L3-4	TRN-0197		Common Mode Choke	Thru-Hole	SEN HUEI INDUSTRIAL CO.,LTD
2	Q1 Q4	ZXTP25020DFL		Transistor, PNP, 20 V, 1.5 A	SOT-23	Zetex
2	Q2-3	FDPF18N50		MOSFET, NCH, 500 V, 18 A, 0.265 $\Omega$	TO-220	Fairchild Semiconductor

**BOM** (Continued)

Qty.	Reference	Part Number	Value	Description	Package Type	Manufacturer
2	R1-2		47 kΩ	RES, SMD, 1/8 W	805	STD
6	R3 R9 R27-28 R33-34		665 kΩ	RES, SMD, 1/8 W	805	STD
1	R4		332 kΩ	RES, SMD, 1/8 W	805	STD
1	R5		68 kΩ	RES, SMD, 1/8 W	805	STD
1	R6		100 kΩ	RES, SMD, 1/8 W	805	STD
2	R7-8		340 kΩ	RES, SMD, 1/8 W	805	STD
2	R10 R20		100 Ω	RES, SMD, 1/8 W	805	STD
2	R11-12		15 Ω	RES, SMD, 1/8 W	805	STD
1	R15		DNP	RES, SMD, 1/8 W	805	STD
1	R16		49.9 Ω	RES, SMD, 1/8 W	805	STD
1	R17		0	RES, SMD, 1/2 W	2010	STD
1	R18	B57237S0509M000	5 Ω	Thermistor, 5 Ω	Thru-Hole	EPCOS
1	R19		14.7 kΩ	RES, SMD, 1/8 W	805	STD
4	1 inserted into each corner of PCB	LCBS-12-01		LOCKING BOARD SUPPORT 3/4", 1 for each PCB corner	Standoff	Richco Plastic Company
1	1 at D5, H2	3103		Nylon Shoulder Washer #4x0.187", Black	Washer	Keystone Electronics
1	1 at D5, H2	MLWZ 003		Split Lock Washer, Metric M 3 Zinc	Washer	B&F Fastener
1	1 at D5, H2	HNZ440		Nut Hex, #4-40 Zinc	Nut	B&F Fastener
1	1 at D5, H2	PMS 440 0050 PH		Screw Machine Phillips, 4-40x1/2" Zinc	Screw	B&F Fastener
1	PWB	FAN9611/12 FEB388 Rev. 0.0.1	FEB388	PWB, 9.8" x 6.8"	PWB	Fairchild Semiconductor
2	R1-2		47 kΩ	RES, SMD, 1/8 W	805	STD
6	R3 R9 R27-28 R33-34		665 kΩ	RES, SMD, 1/8 W	805	STD
1	R4		332 kΩ	RES, SMD, 1/8 W	805	STD
1	R5		68 kΩ	RES, SMD, 1/8 W	805	STD
1	R6		100 kΩ	RES, SMD, 1/8 W	805	STD
2	R7-8		340 kΩ	RES, SMD, 1/8 W	805	STD
2	R10 R20		100 Ω	RES, SMD, 1/8 W	805	STD
2	R11-12		15 Ω	RES, SMD, 1/8 W	805	STD
2	R13-14		0.022 Ω	RES, SMD, 1/2 W	1812	STD
1	R15		DNP	RES, SMD, 1/8 W	805	STD
1	R16		49.9 Ω	RES, SMD, 1/8 W	805	STD
1	U1	FAN9611		Interleaved Dual-BCM PFC Controller	SOIC-16	Fairchild Semiconductor

**Note:**

2. DNP = Do not populate. STD = standard components.



## 10. Test Results

### 10.1. Startup

Figure 15 and Figure 16 show the startup operation at 115 V<sub>AC</sub> line voltage for no-load and full-load condition, respectively. Due to the closed-loop soft-start, almost no overshoot is observed for no-load startup and full-load startup.

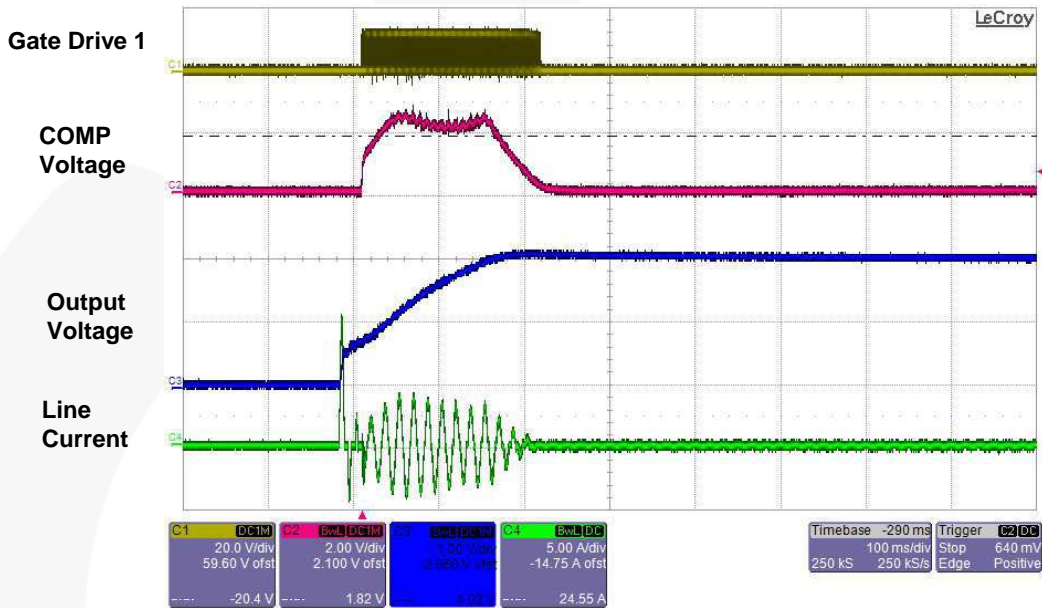

CH1: Gate Drive 1 Voltage (20 V / div), CH2: COMP Voltage (2 V / div),  
CH3: Output Voltage (200 V / div), CH4: Line Current (5 A / div), Time (100 ms / div)

**Figure 15. No-Load Startup at 115 V<sub>AC</sub>**

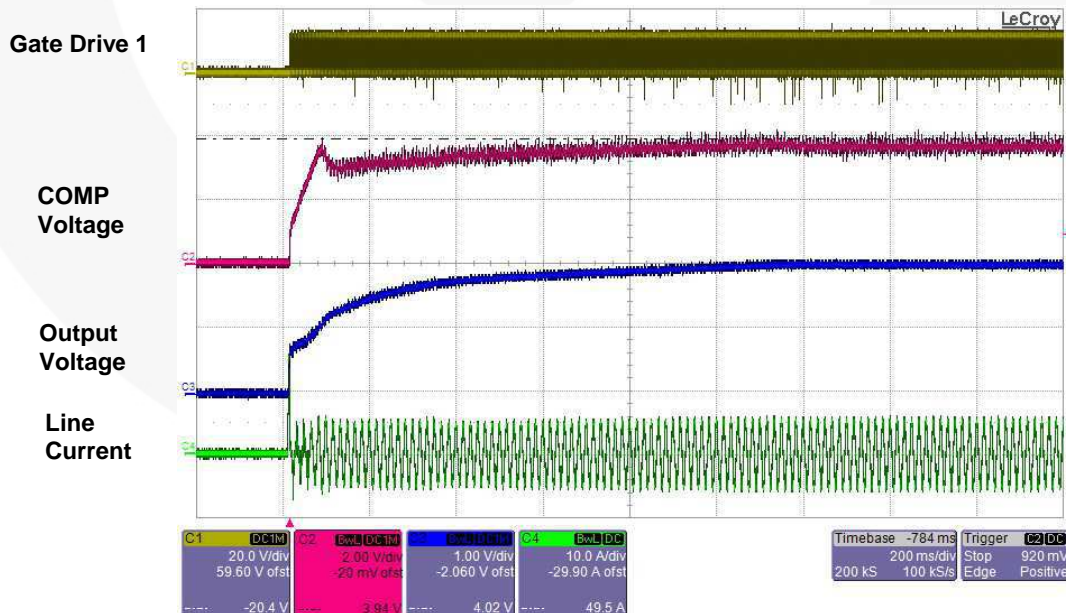

CH1: Gate Drive 1 Voltage (20 V / div), CH2: COMP Voltage (2 V / div),  
CH3: Output Voltage (200 V / div), CH4: Line Current (10 A / div), Time (200 ms / div)

**Figure 16. Full-Load Startup at 115 V<sub>AC</sub>**

Figure 17 and Figure 18 show the startup operation at 230 V<sub>AC</sub> line voltage for no-load and full-load conditions, respectively. Due to the closed-loop soft-start, almost no overshoot is observed for no-load startup and full-load startup.

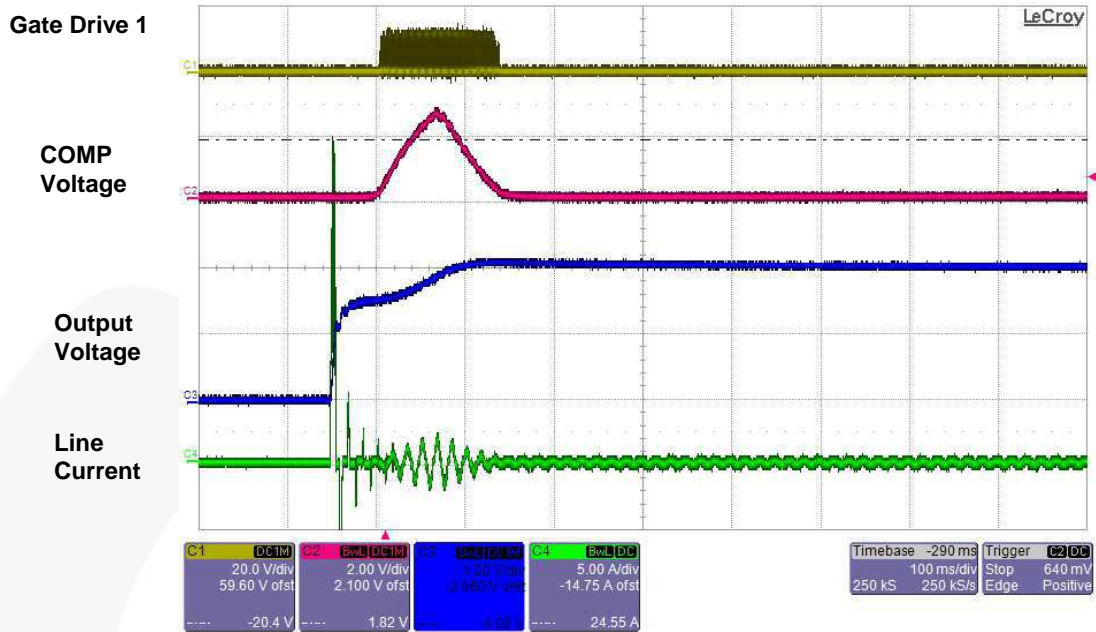

CH1: Gate Drive 1 Voltage (20 V / div), CH2: COMP Voltage (2 V / div),  
CH3: Output Voltage (200 V / div), CH4: Line Current (5 A / div), Time (100 ms / div)

Figure 17. No-Load Startup at 230 V<sub>AC</sub>

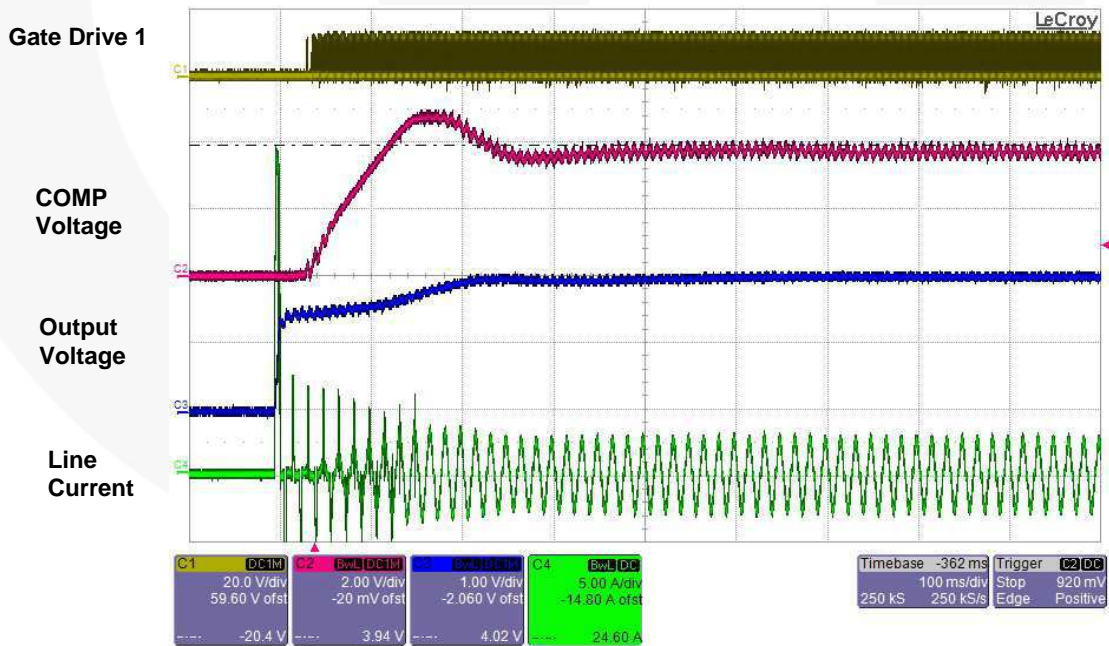

CH1: Gate Drive 1 Voltage (20 V / div), CH2: COMP Voltage (2 V / div),  
CH3: Output Voltage (200 V / div), CH4: Line Current (5 A / div), Time (100 ms / div)

Figure 18. Full-Load Startup at 230 V<sub>AC</sub>

## 10.2. Normal Operation

Figure 19 and Figure 20 show the two inductor currents and sum of two inductor currents at 115 V<sub>AC</sub> line voltage and full-load conditions. The sum of the inductor currents has relatively small ripple due to the ripple cancellation of interleaving operation.

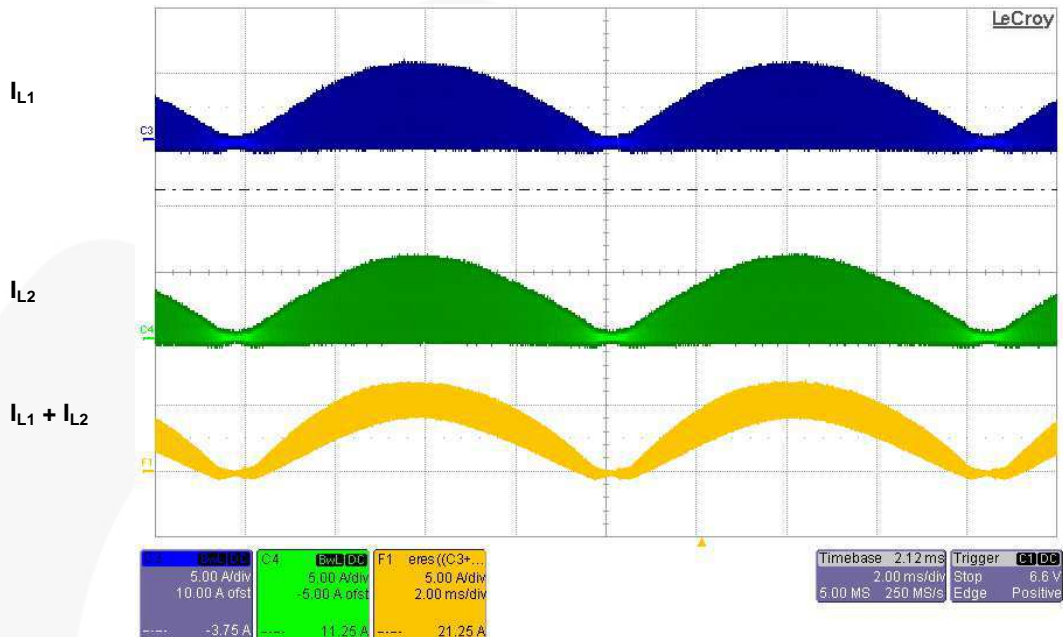

CH3: Inductor L1 Current (5 A / div), CH4: Inductor L2 Current (5 A / div),  
F1: Sum of Two Inductor Current (5 A / div), Time (2 ms / div)

**Figure 19. Inductor Current Waveforms at Full-Load and 115 V<sub>AC</sub>**

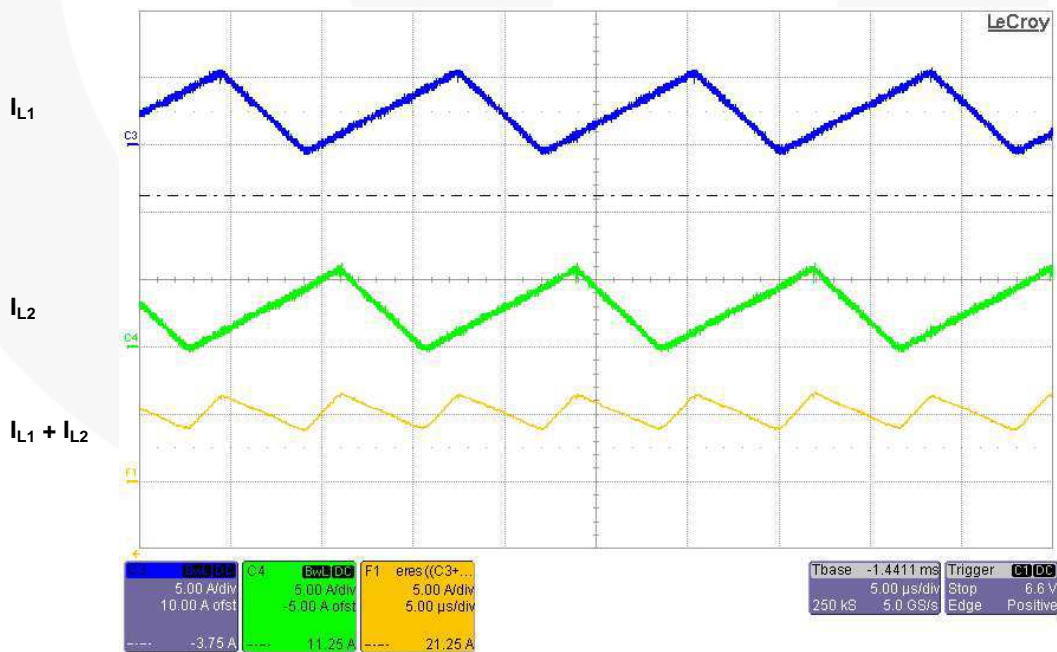

CH3: Inductor L1 Current (5 A / div), CH4: Inductor L2 Current (5 A / div),  
F1: Sum of Two Inductor Current (5 A / div), Time (5 μs / div)

**Figure 20. Zoom of Inductor Current Waveforms of Figure 19 at Peak of Line Voltage**

Figure 21 and Figure 22 show the two inductor currents and sum of two inductor currents at 230 V<sub>AC</sub> line voltage and full-load conditions. The sum of the inductor currents has relatively small ripple due to the ripple cancellation of interleaving operation.

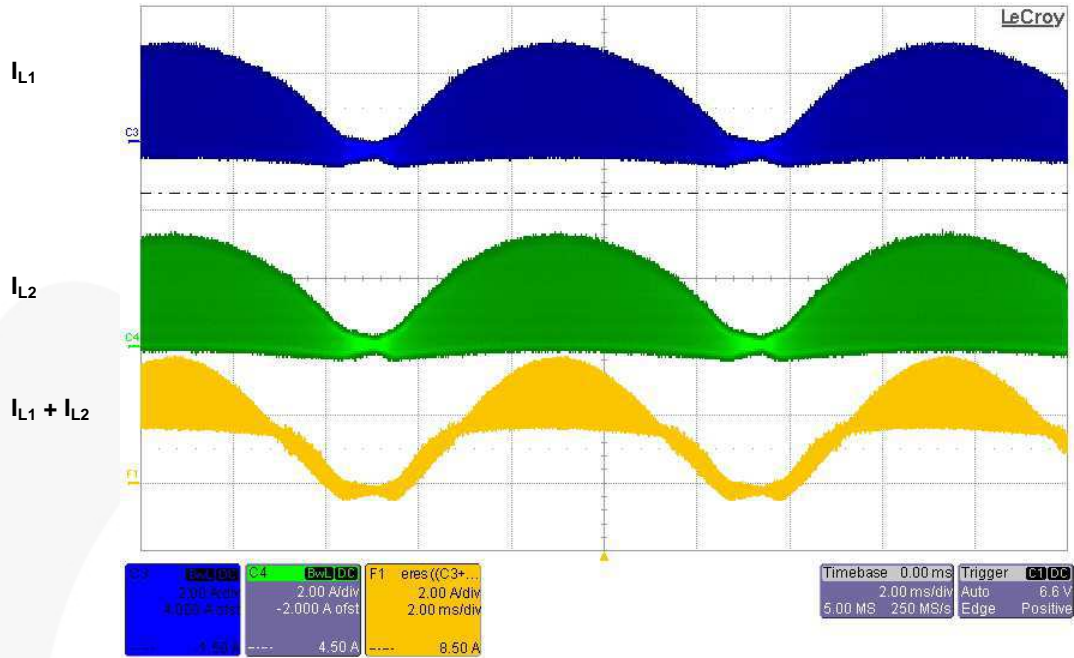

CH3: Inductor L1 Current (2 A / div), CH4: Inductor L2 Current (2 A / div), F1: Sum of Two Inductor Current (2 A / div), Time (2 ms / div)

**Figure 21. Inductor Current Waveforms at Full-Load and 230 V<sub>AC</sub>**

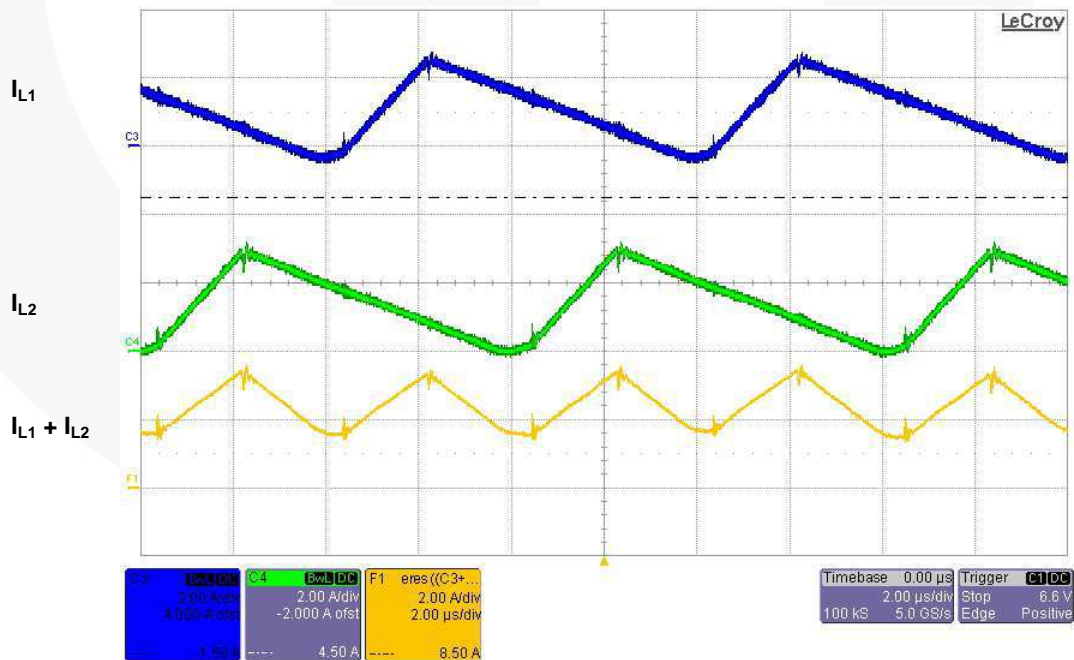

CH3: Inductor L1 Current (2 A / div), CH4: Inductor L2 Current (2 A / div), F1: Sum of Two Inductor Current (2 A / div), Time (2 μs / div)

**Figure 22. Zoom of Inductor Current Waveforms of Figure 21 at Peak of Line Voltage**

### 10.3. Line Transient

Figure 23 and Figure 24 show the line transient operation and minimal effect on output voltage due to the line feed-forward function. When the line voltage changes from 230 V<sub>AC</sub> to 115 V<sub>AC</sub>, about 20 V (5% of nominal output voltage) voltage undershoot is observed. When the line voltage changes from 115 V<sub>AC</sub> to 230 V<sub>AC</sub>, almost no voltage undershoot is observed.

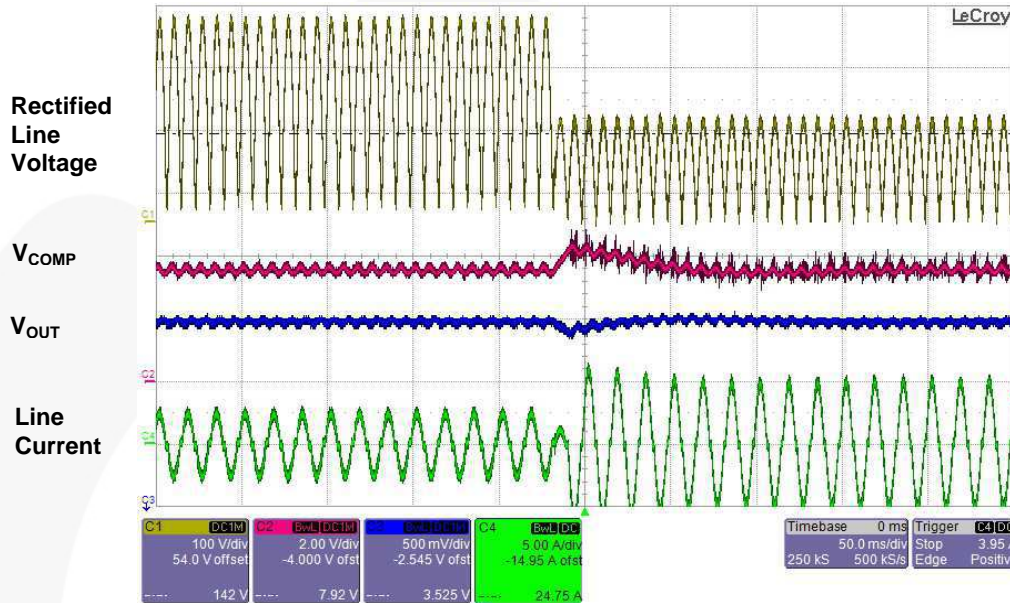

CH1: Rectified Line Voltage (100 V / div), CH2: COMP Voltage (2 V / div),  
CH3: Output Voltage (100 V / div), CH4: Line Current (5 A / div), Time (50 ms / div)

**Figure 23. Line Transient Response at Full-Load Condition (230 V<sub>AC</sub> → 115 V<sub>AC</sub>)**

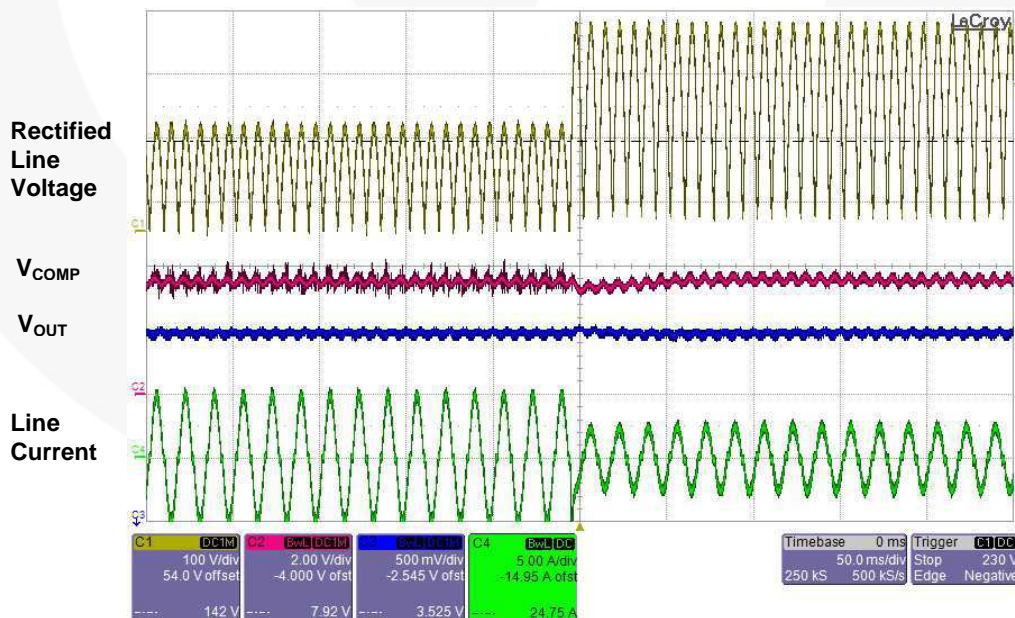

CH1: Rectified Line Voltage (100 V / div), CH2: COMP Voltage (2 V / div),  
CH3: Output Voltage (100 V / div), CH4: Line Current (5 A / div), Time (50 ms / div)

**Figure 24. Line Transient Response at Full-Load Condition (115 V<sub>AC</sub> → 230 V<sub>AC</sub>)**

## 10.4. Load Transient

Figure 25 and Figure 26 show the load-transient operation. When the output load changes from 100% to 0%, 26 V (6.5% of nominal output voltage) voltage overshoot is observed. When the output load changes from 0% to 100%, 43 V (11% of nominal output voltage) voltage undershoot is observed.

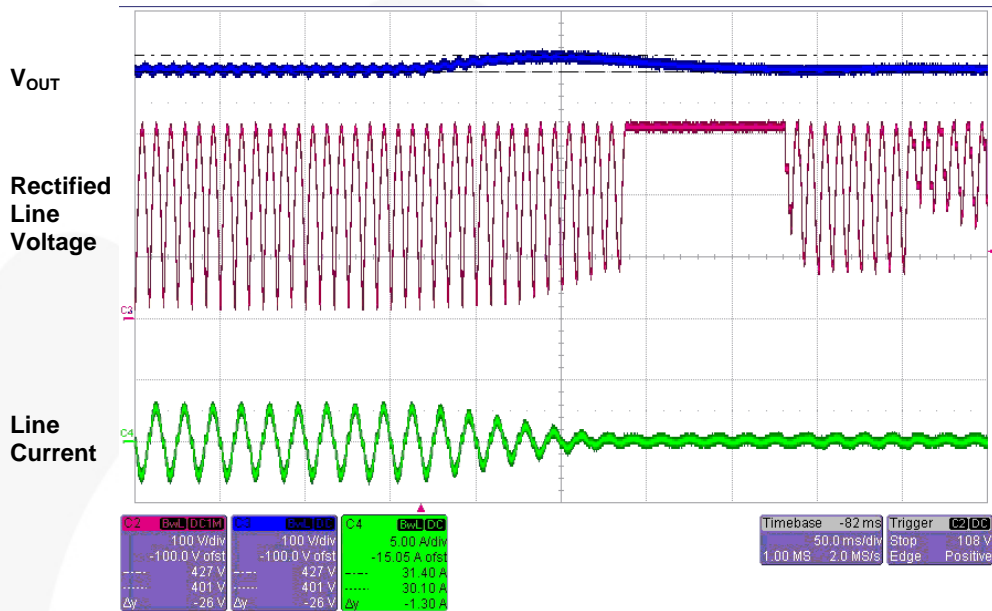

CH2: Rectified line voltage (100 V / div), CH3: Output voltage (100 V / div),  
CH4: Line current (5 A / div), Time (50 ms / div)

**Figure 25. Load Transient Response at 230 V<sub>AC</sub> (Full Load → No Load)**

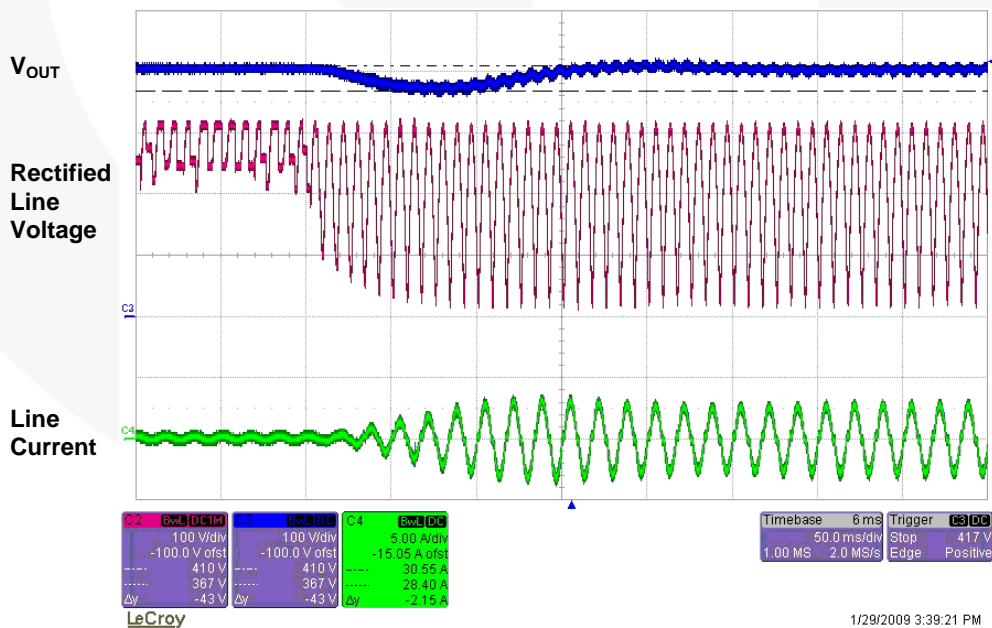

CH2: Rectified Line Voltage (100 V / div), CH3: Output Voltage (100 V / div),  
CH4: Line Current (5 A / div), Time (50 ms / div)

**Figure 26. Load Transient Response at 230 V<sub>AC</sub> (No Load → Full Load)**

## 10.5. Brownout Protection

Figure 27 and Figure 28 show the startup operation at slowly increasing line voltage. The power supply starts up when the line voltage reaches around 78 V<sub>AC</sub>.

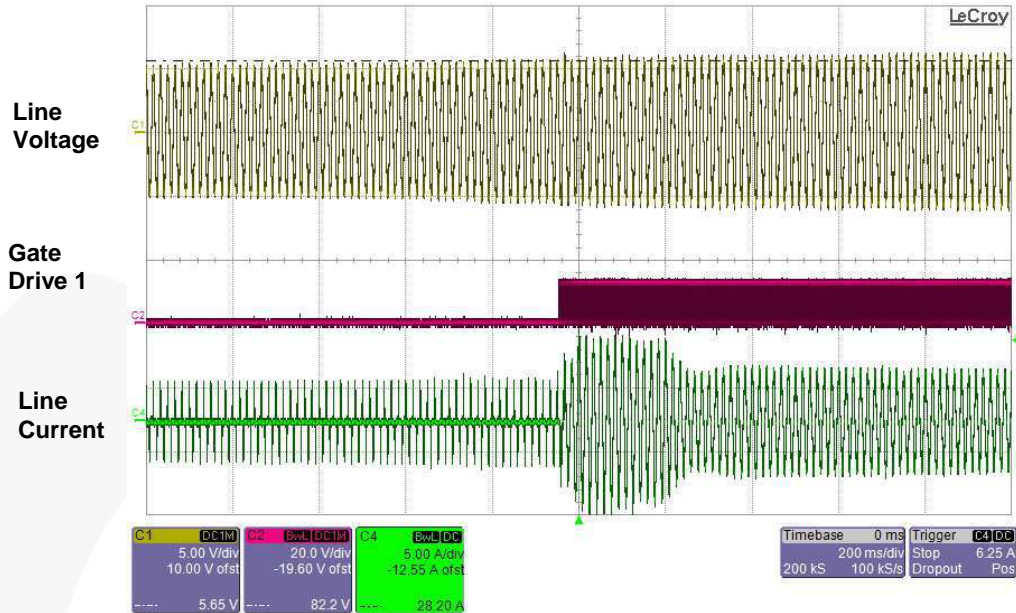

CH1: Line Voltage (100 V / div), CH2: Gate Drive 1 Voltage (20 V / div),  
CH4: Line Current (5 A / div), Time (200 ms / div)

**Figure 27. Startup Slowly Increasing the Line Voltage**

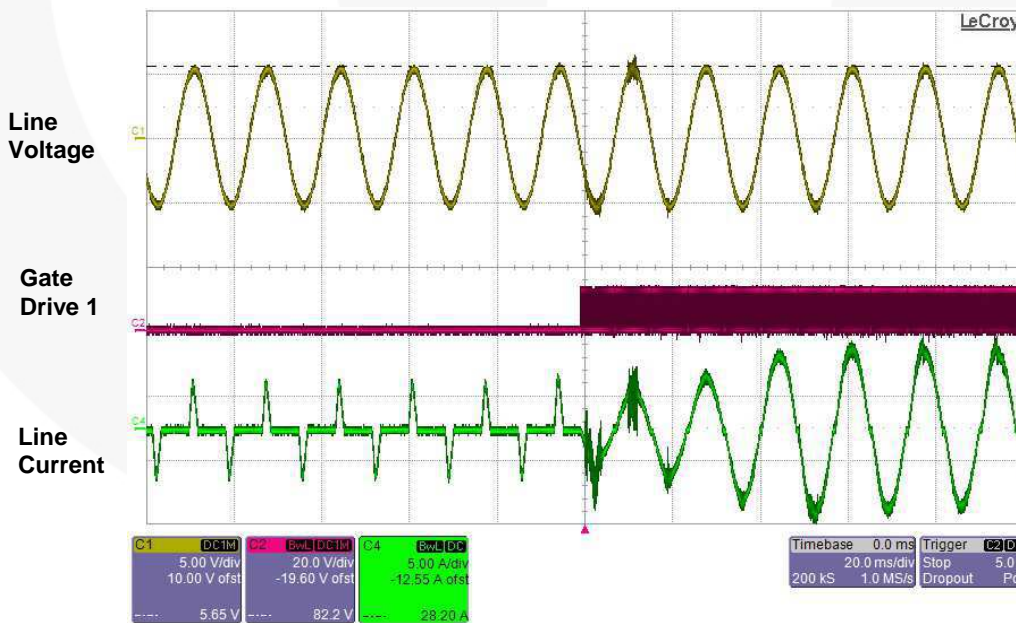

CH1: Line Voltage (100 V / div), CH2: Gate Drive 1 Voltage (20 V / div),  
CH4: Line Current (5 A / div), Time (20 ms / div)

**Figure 28. Shutdown Slowly Decreasing the Line Voltage**

Figure 29 and Figure 30 show the shutdown operation at slowly decreasing line voltage. The power shuts down when line voltage drops below 68 V<sub>AC</sub>.

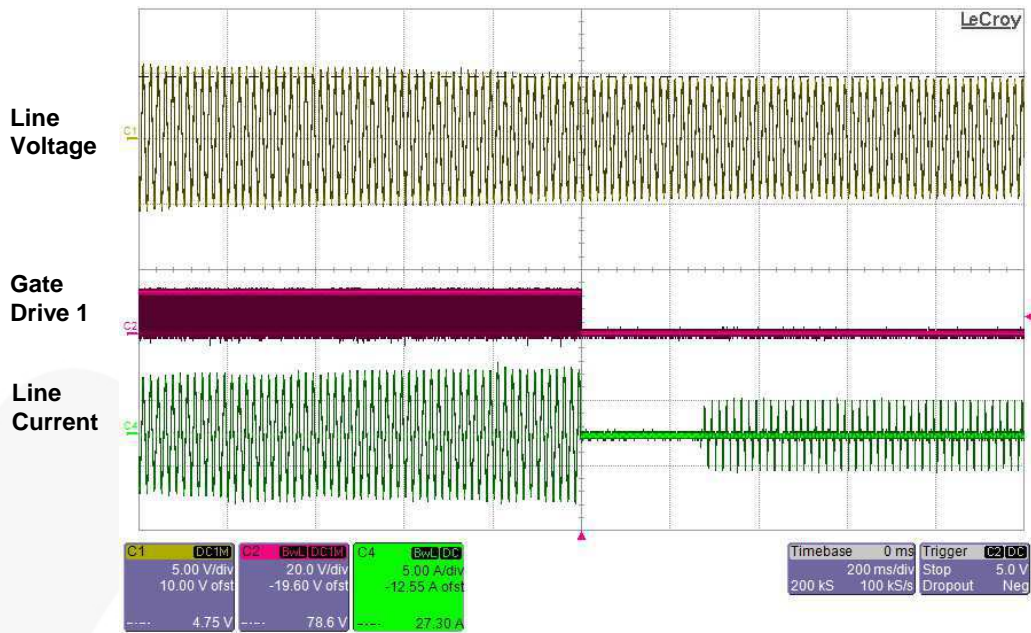

CH1: Line Voltage (100 V / div), CH2: Gate Drive 1 Voltage (20 V / div),  
CH4: Line Current (5 A / div), Time (200 ms / div)

**Figure 29. Startup Slowly Increasing the Line Voltage**

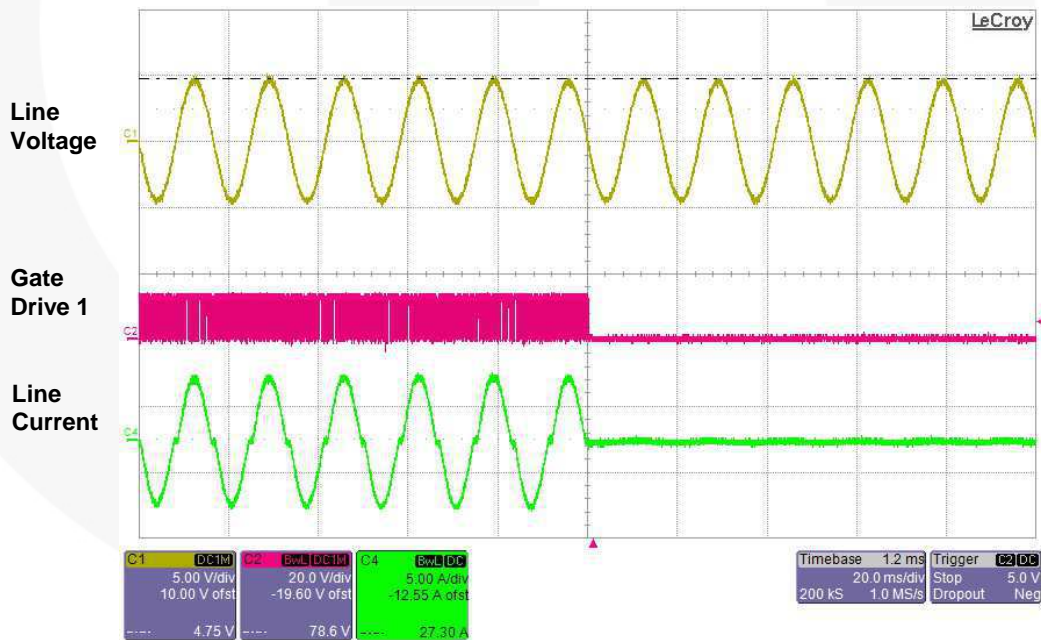

CH1: Line Voltage (100 V / div), CH2: Gate Drive 1 Voltage (20 V / div),  
CH4: Line Current (5 A / div), Time (20 ms / div)

**Figure 30. Shutdown Slowly Decreasing the Line Voltage**



## 10.6. Phase Management

Figure 31 and Figure 32 show the phase-shedding waveforms. As observed, when the gate drive signal of Channel 2 is disabled, the duty cycle of Channel 1 gate drive signal is doubled to minimize the line current glitch and guarantee smooth transient.

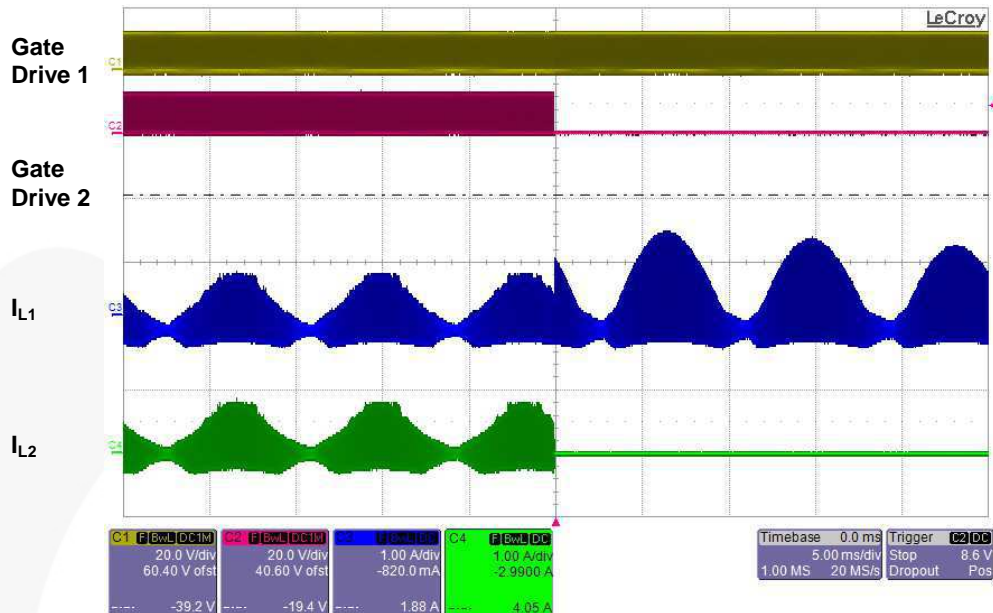

CH1: Gate Drive 1 Voltage (20 V / div), CH2: Gate Drive 2 Voltage (20 V / div),  
CH3: Inductor L1 Current (1 A / div), CH4: Inductor L2 Current (1 A / div), Time (5 ms / div)

**Figure 31. Phase-Shedding Operation**

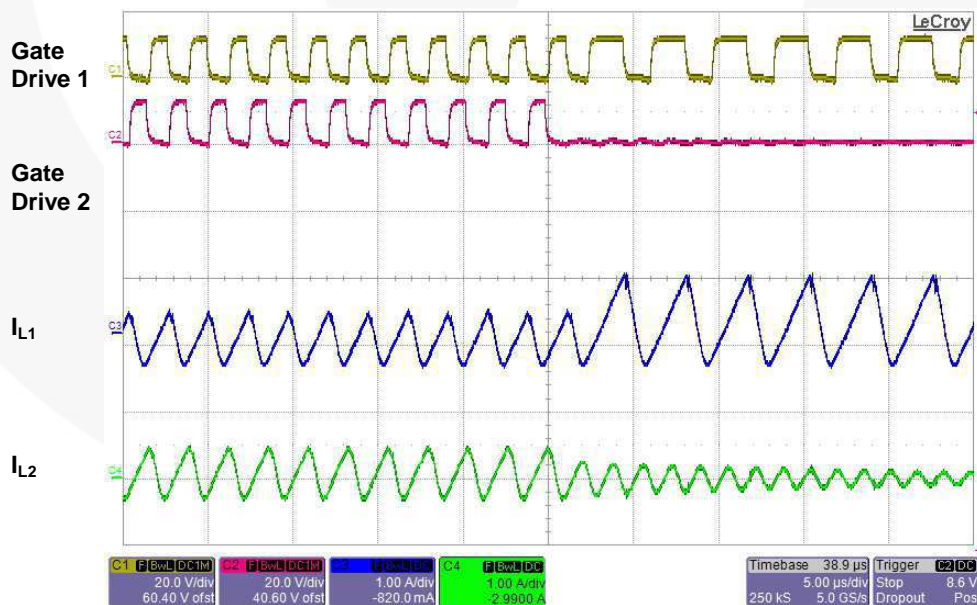

CH1: Gate Drive 1 Voltage (20 V / div), CH2: Gate Drive 2 Voltage (20 V / div),  
CH3: Inductor L1 Current (1 A / div), CH4: Inductor L2 Current (1 A / div), Time (5 μs / div)

**Figure 32. Phase-Shedding Operation (Zoomed-in Timescale)**

Figure 33 and Figure 34 show the phase-adding waveforms. As observed, just before the Channel 2 gate drive signal is enabled, the duty cycle of Channel 1 gate drive signal is halved to minimize the line current glitch and guarantee smooth transient. In Figure 34, the first pulse of gate drive 2 during the phase-adding operation is skipped to ensure 180 degrees out-of-phase interleaving operation during transient.

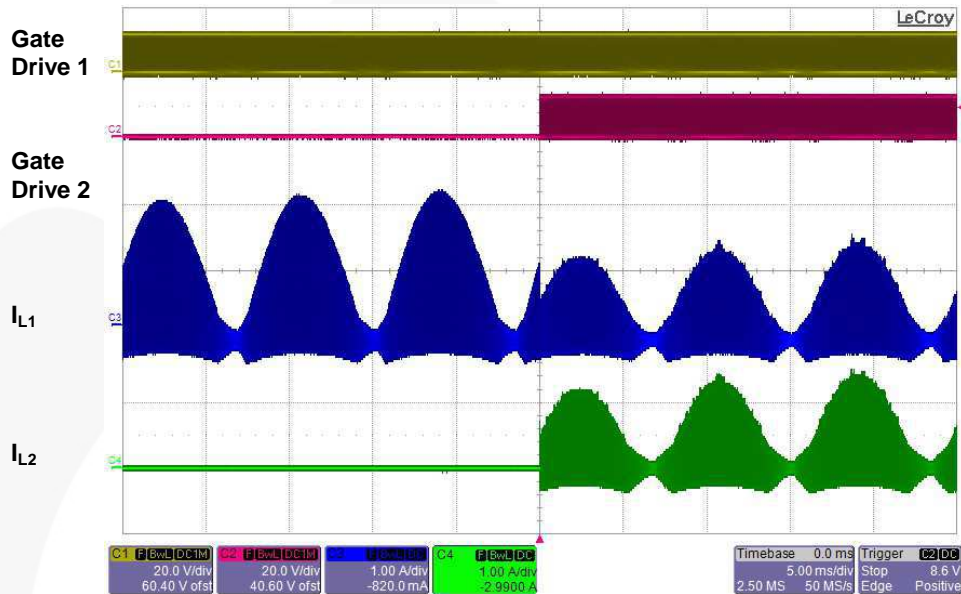

CH1: Gate Drive 1 Voltage (20 V / div), CH2: Gate Drive 2 Voltage (20 V / div),  
CH3: Inductor L1 Current (1 A / div), CH4: Inductor L2 Current (1 A / div), Time (5 ms / div)

**Figure 33. Phase-Adding Operation**

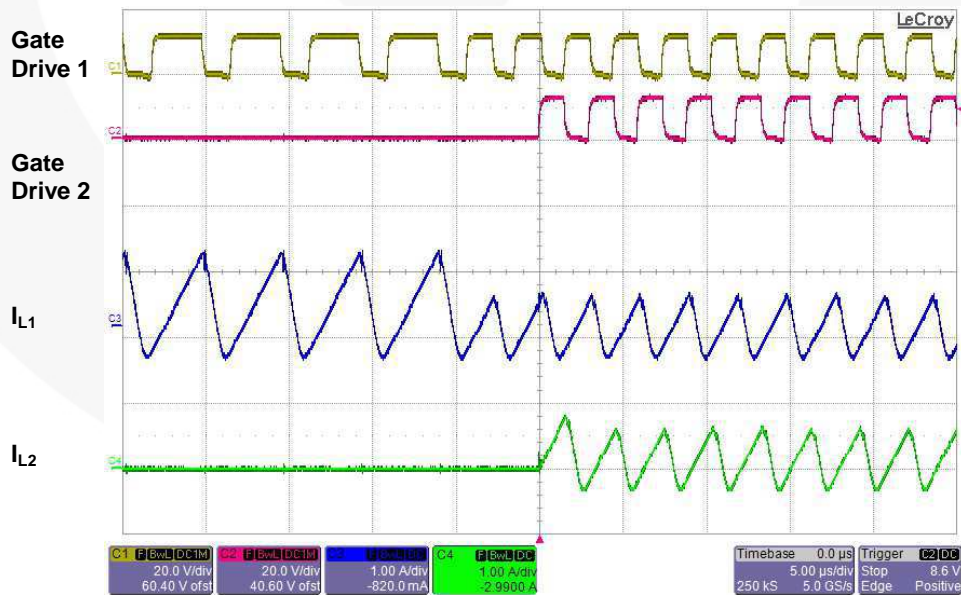

CH1: Gate Drive 1 Voltage (20 V / div), CH2: Gate Drive 2 Voltage (20 V / div),  
CH3: Inductor L1 Current (1 A / div), CH4: Inductor L2 Current (1 A / div), Time (5 μs / div)

**Figure 34. Phase-Adding Operation (Zoomed-in Timescale)**

Figure 35 and Figure 36 show the sum of two-inductor current and line current for phase shedding and adding, respectively. The small line-current glitch during phase management exists because the actual average value of inductor current is less than half of the peak value due to the negative portion of inductor current, as shown in Figure 32 and Figure 34. However, the phase management takes place at relatively light-load condition and the effect of this phenomenon is negligible.

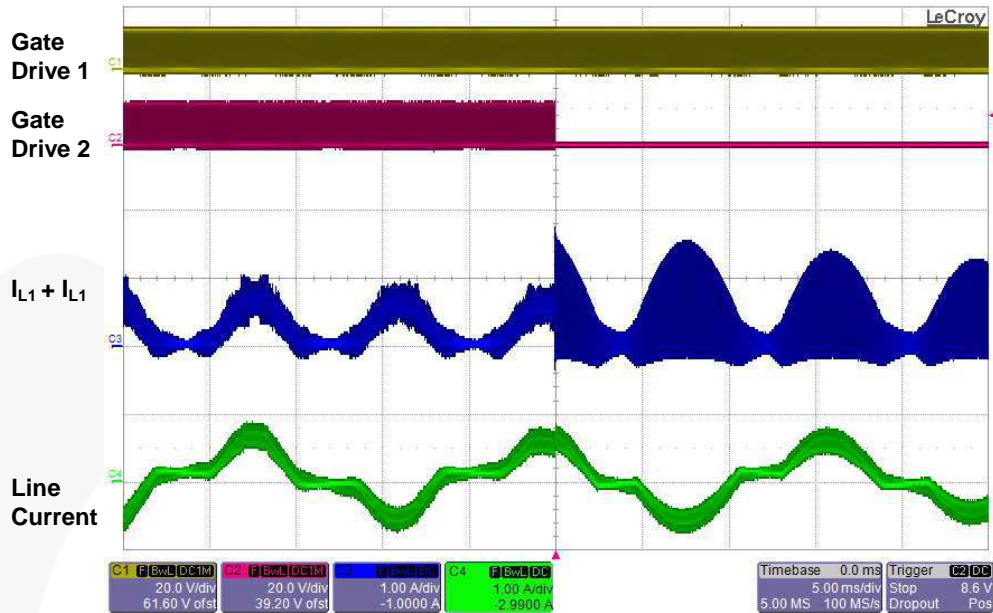

CH1: Gate Drive 1 Voltage (20 V / div), CH2: Gate Drive 2 Voltage (20 V / div),  
CH3: Sum of Two Inductor Currents (1 A / div), CH4: Line Current (1 A / div), Time (5 ms / div)

**Figure 35. Phase Shedding and Line Current**

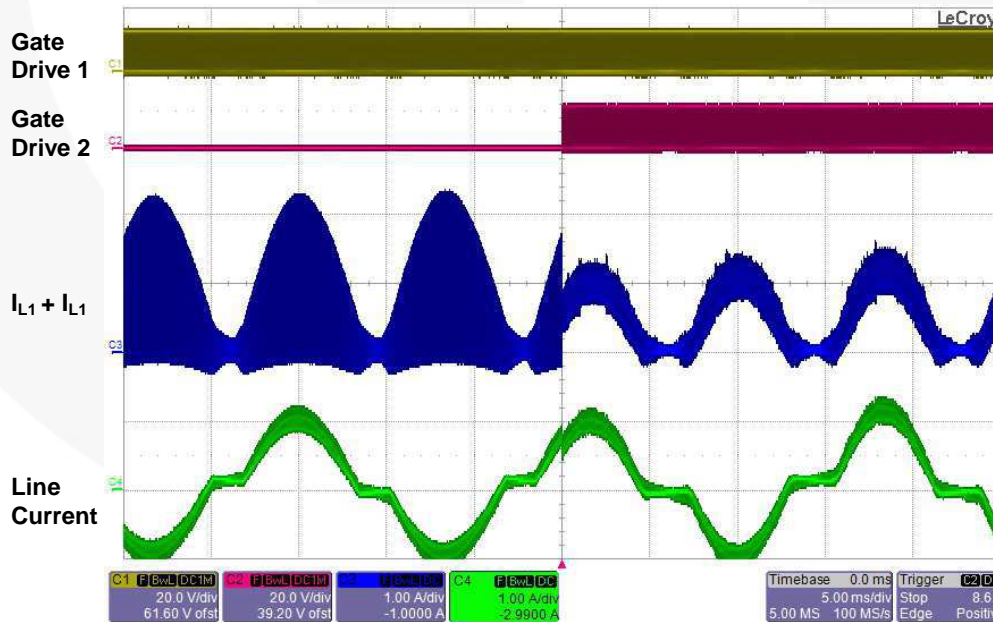

CH1: Gate Drive 1 Voltage (20 V / div), CH2: Gate Drive 2 Voltage (20 V / div),  
CH3: Sum of Two Inductor Currents (1 A / div), CH4: Line Current (1 A / div), Time (5 ms / div)

**Figure 36. Phase Adding Operation and Line Current**

## 10.7. Efficiency

Figure 37 through Figure 40 show the measured efficiency of the 400 W evaluation board with and without phase management at input voltages of 115 V<sub>AC</sub> and 230 V<sub>AC</sub>. Phase management improves the efficiency at light load by up to 7%, depending on the line voltage and load condition. The phase management thresholds on the test evaluation board are around 15% of the nominal output power (Figure 37 and Figure 38). They can be adjusted upwards to achieve a more desirable efficiency profile (Figure 39 and Figure 40) by increasing the MOT resistor.

Since phase shedding reduces the switching loss by effectively decreasing the switching frequency at light load, a greater efficiency improvement is achieved at 230 V<sub>AC</sub>, where switching losses dominate. Relatively less improvement is obtained at 115 V<sub>AC</sub> since the MOSFET is turned on with zero voltage and switching losses are negligible.

The efficiency measurements include the losses in the EMI filter as well as cable loss; however, the power consumption of the control IC (<< 1 W) is not included since an external power supply is used for V<sub>DD</sub>.

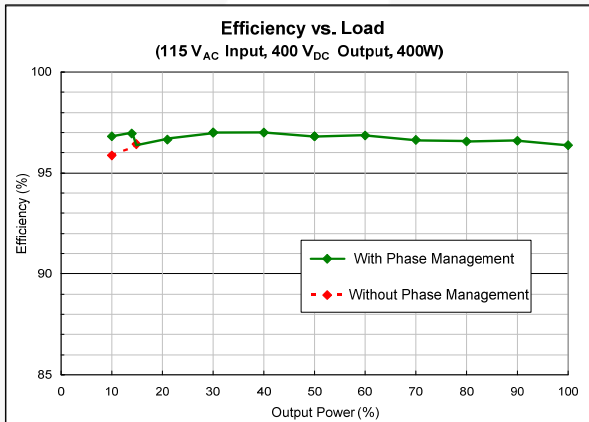

**Figure 37. Measured Efficiency at 115 V<sub>AC</sub> (Default Thresholds)**

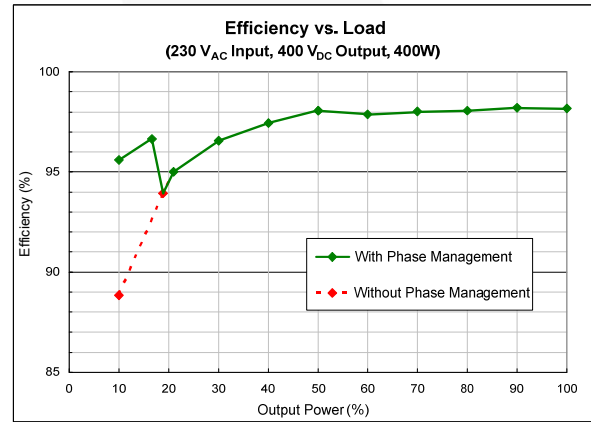

**Figure 38. Measured Efficiency at 230 V<sub>AC</sub> (Default Thresholds)**

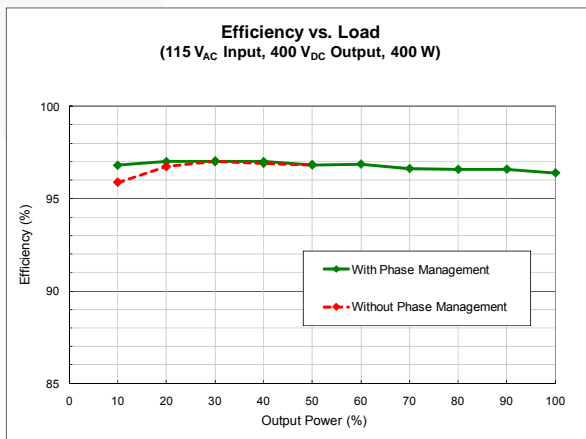

**Figure 39. Measured Efficiency at 115 V<sub>AC</sub> (Adjusted Thresholds)**

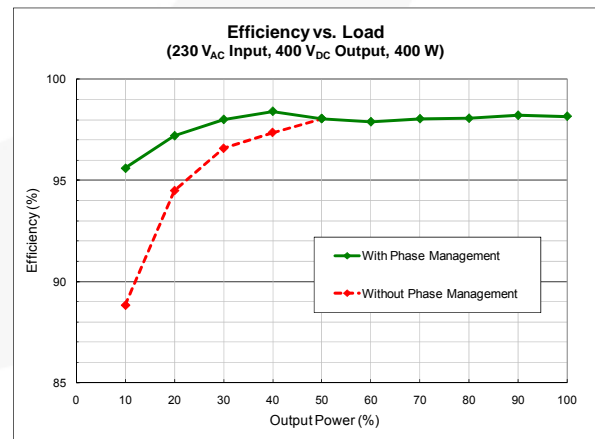

**Figure 40. Measured Efficiency at 230 V<sub>AC</sub> (Adjusted Thresholds)**

## 10.8. Harmonic Distortion and Power Factor

Figure 41 and Figure 42 compare the measured harmonic current with EN61000 class D and C, respectively, at input voltages of 115 V<sub>AC</sub> and 230 V<sub>AC</sub>. Class D is applied to TV and PC power, while Class C is applied to lighting applications. As can be observed, both regulations are met with sufficient margin.

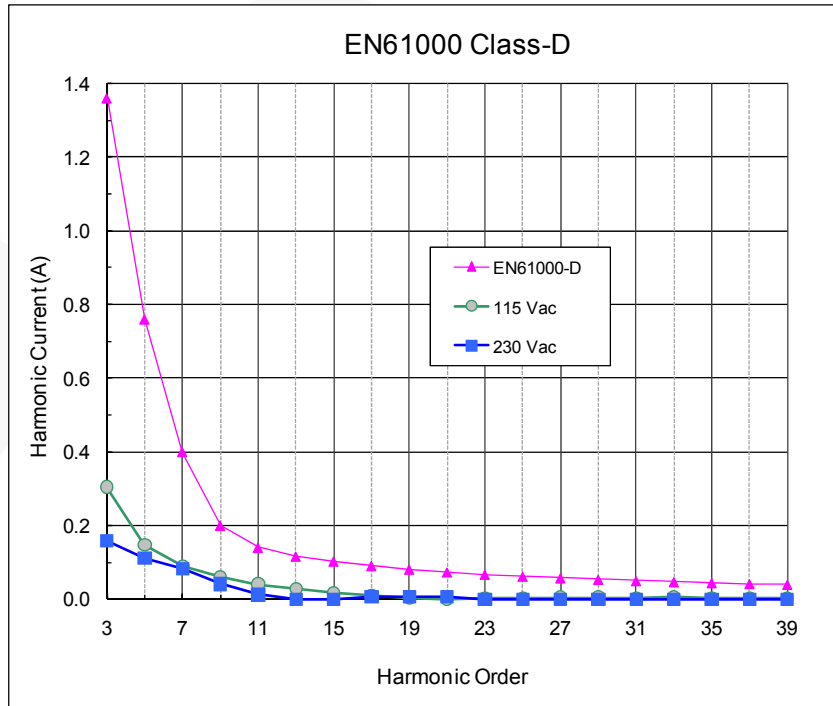

Figure 41. Measured Harmonic Current and EN61000 Class-D Regulation

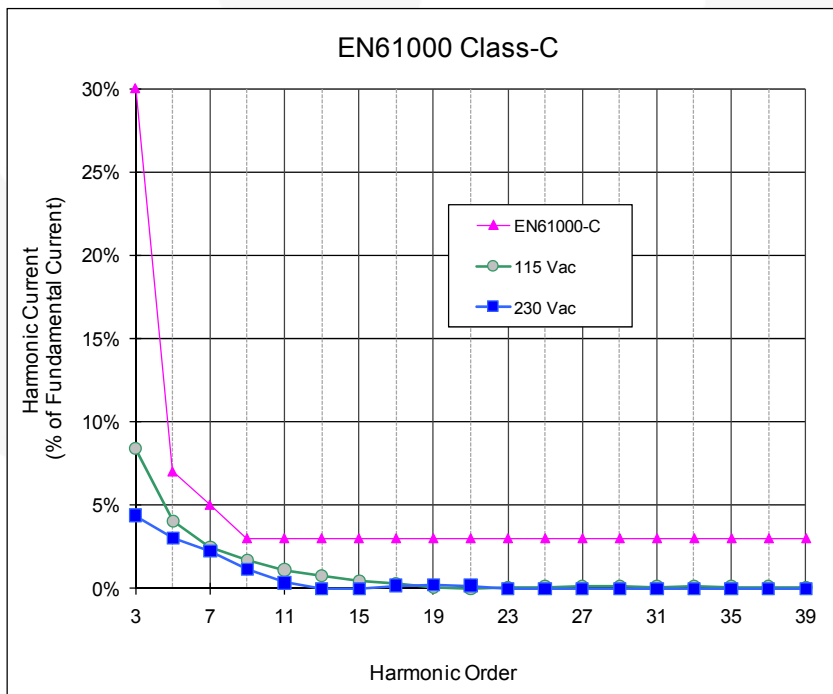

Figure 42. Measured Harmonic Current and EN61000 Class-C Regulation

Figure 43 shows the measured power factors at input voltage of 115 V<sub>AC</sub> and 230 V<sub>AC</sub>. As observed, high power factor above 0.98 is obtained from 100% to 50% load. Table 4 shows the total harmonic distortion at input voltages of 115 V<sub>AC</sub> and 230 V<sub>AC</sub>.

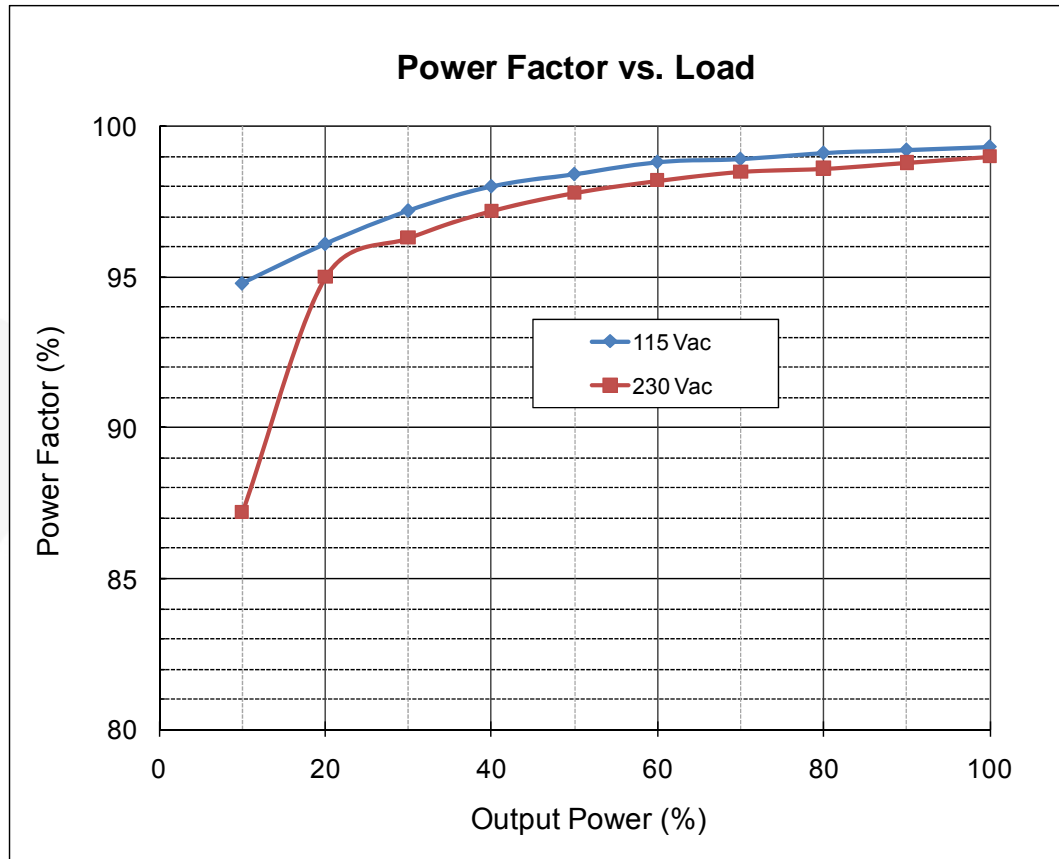

Figure 43. Measured Power Factor

Table 4. Total Harmonic Distortion (THD)

Line Voltage	100% Load	75% Load	50% Load	25% Load
115 V <sub>AC</sub>	9.68%	11.82%	15.87%	24.08%
230 V <sub>AC</sub>	11.36%	12.95%	15.30%	16.81%

## 11. References

[Datasheet: FAN9611– Interleaved Dual BCM PFC Controller](#)

[AN-6086 – “Design Consideration for interleaved Boundary Conduction Mode \(BCM\) PFC Using FAN9611 / FAN9612”](#)

## 12. Ordering Information

Orderable Part Number	Description
FEBFAN9611_S388V1	FAN9611 400 W Evaluation Board

## 13. Revision History

Date	Rev. #	Description
May 2013	0.0.5	Initial release/replacing AN-9717 (FEB388-001)

---

**WARNING AND DISCLAIMER**

Replace components on the Evaluation Board only with those parts shown on the parts list (or Bill of Materials) in the Users' Guide. Contact an authorized Fairchild representative with any questions.

The Evaluation board (or kit) is for demonstration purposes only and neither the Board nor this User's Guide constitute a sales contract or create any kind of warranty, whether express or implied, as to the applications or products involved. Fairchild warrants that its products meet Fairchild's published specifications, but does not guarantee that its products work in any specific application. Fairchild reserves the right to make changes without notice to any products described herein to improve reliability, function, or design. Either the applicable sales contract signed by Fairchild and Buyer or, if no contract exists, Fairchild's standard Terms and Conditions on the back of Fairchild invoices, govern the terms of sale of the products described herein.

**DISCLAIMER**

FAIRCHILD SEMICONDUCTOR RESERVES THE RIGHT TO MAKE CHANGES WITHOUT FURTHER NOTICE TO ANY PRODUCTS HEREIN TO IMPROVE RELIABILITY, FUNCTION, OR DESIGN. FAIRCHILD DOES NOT ASSUME ANY LIABILITY ARISING OUT OF THE APPLICATION OR USE OF ANY PRODUCT OR CIRCUIT DESCRIBED HEREIN; NEITHER DOES IT CONVEY ANY LICENSE UNDER ITS PATENT RIGHTS, NOR THE RIGHTS OF OTHERS.

**LIFE SUPPORT POLICY**

FAIRCHILD'S PRODUCTS ARE NOT AUTHORIZED FOR USE AS CRITICAL COMPONENTS IN LIFE SUPPORT DEVICES OR SYSTEMS WITHOUT THE EXPRESS WRITTEN APPROVAL OF THE PRESIDENT OF FAIRCHILD SEMICONDUCTOR CORPORATION.

As used herein:

1. Life support devices or systems are devices or systems which, (a) are intended for surgical implant into the body, or (b) support or sustain life, or (c) whose failure to perform when properly used in accordance with instructions for use provided in the labeling, can be reasonably expected to result in significant injury to the user.
2. A critical component is any component of a life support device or system whose failure to perform can be reasonably expected to cause the failure of the life support device or system, or to affect its safety or effectiveness.

---

**ANTI-COUNTERFEITING POLICY**

Fairchild Semiconductor Corporation's Anti-Counterfeiting Policy. Fairchild's Anti-Counterfeiting Policy is also stated on our external website, [www.fairchildsemi.com](http://www.fairchildsemi.com), under Sales Support.

Counterfeiting of semiconductor parts is a growing problem in the industry. All manufacturers of semiconductor products are experiencing counterfeiting of their parts. Customers who inadvertently purchase counterfeit parts experience many problems such as loss of brand reputation, substandard performance, failed applications, and increased cost of production and manufacturing delays. Fairchild is taking strong measures to protect ourselves and our customers from the proliferation of counterfeit parts. Fairchild strongly encourages customers to purchase Fairchild parts either directly from Fairchild or from Authorized Fairchild Distributors who are listed by country on our web page cited above. Products customers buy either from Fairchild directly or from Authorized Fairchild Distributors are genuine parts, have full traceability, meet Fairchild's quality standards for handling and storage and provide access to Fairchild's full range of up-to-date technical and product information. Fairchild and our Authorized Distributors will stand behind all warranties and will appropriately address any warranty issues that may arise. Fairchild will not provide any warranty coverage or other assistance for parts bought from Unauthorized Sources. Fairchild is committed to combat this global problem and encourage our customers to do their part in stopping this practice by buying direct or from authorized distributors.