

# FAN8005D2

## 3-CH Motor Driver

### Features

- 3-Channel BTL (Balanced transformer-less) driver
- Built-in variable regulator with reset (Series-REG)
- Built-in thermal shutdown circuit
- Built-in power save circuit
- Built-in general OP-amp
- Operating supply voltage: 4.5V ~ 5.5V
- Corresponds to 3.3V or 5V DSP

### Description

The FAN8005D2 is a monolithic integrated circuit, suitable for a 3-ch motor driver which drives focus actuator, tracking actuator, and sled motor of a CD-media system.



### Typical Applications

- Compact disk player
- Digital video disk player
- Compact disk ROM

### Ordering Information

Device	Package	Operating Temp.
FAN8005D2	28-SSOPH-300	-35°C ~ +85°C
FAN8005D2TF	28-SSOPH-300	-35°C ~ +85°C

## Pin Assignments

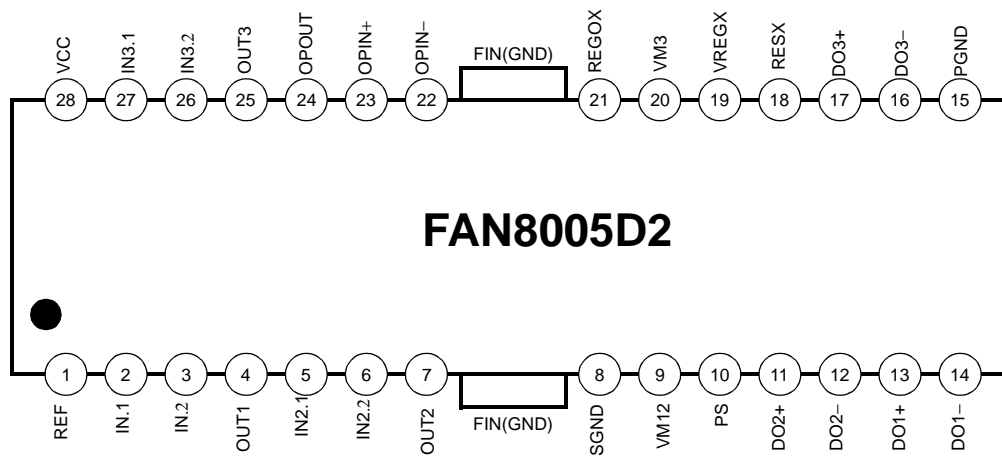

## Pin Definitions

Pin Number	Pin Name	I/O	Pin Function Description
1	REF	I	Bias voltage input
2	IN1.1	I	Op-amp CH1 input (+)
3	IN1.2	I	Op-amp CH1 input (-)
4	OUT1	O	Op-amp CH1 output
5	IN2.1	I	Op-amp CH2 input (+)
6	IN2.2	I	Op-amp CH2 input (-)
7	OUT2	O	Op-amp CH2 output
8	SGND	-	Signal ground
9	VM12	-	BTL CH1, 2 supply voltage
10	PS	I	Power save
11	DO2+	O	Drive2 output (+)
12	DO2-	O	Drive2 output (-)
13	DO1+	O	Drive1 output (+)
14	DO1-	O	Drive1 output (-)
15	PGND	-	Power ground
16	DO3-	O	Drive3 output (-)
17	DO3+	O	Drive3 output (+)
18	RESX	I	Regulator reset
19	VREGX	O	Op-amp output
20	VM3	-	BTL CH3 supply voltage
21	REGOX	I	Op-amp input(+)
22	OPIN-	I	Op-amp input (-)
23	OPIN+	I	Op-amp input (+)
24	OPOUT	O	Op-amp output
25	OUT3	O	Op-amp CH3 output
26	IN3.2	I	Op-amp CH3 input (-)
27	IN3.1	I	Op-amp CH3 input (+)
28	VCC	-	Supply voltage

# Internal Block Diagram

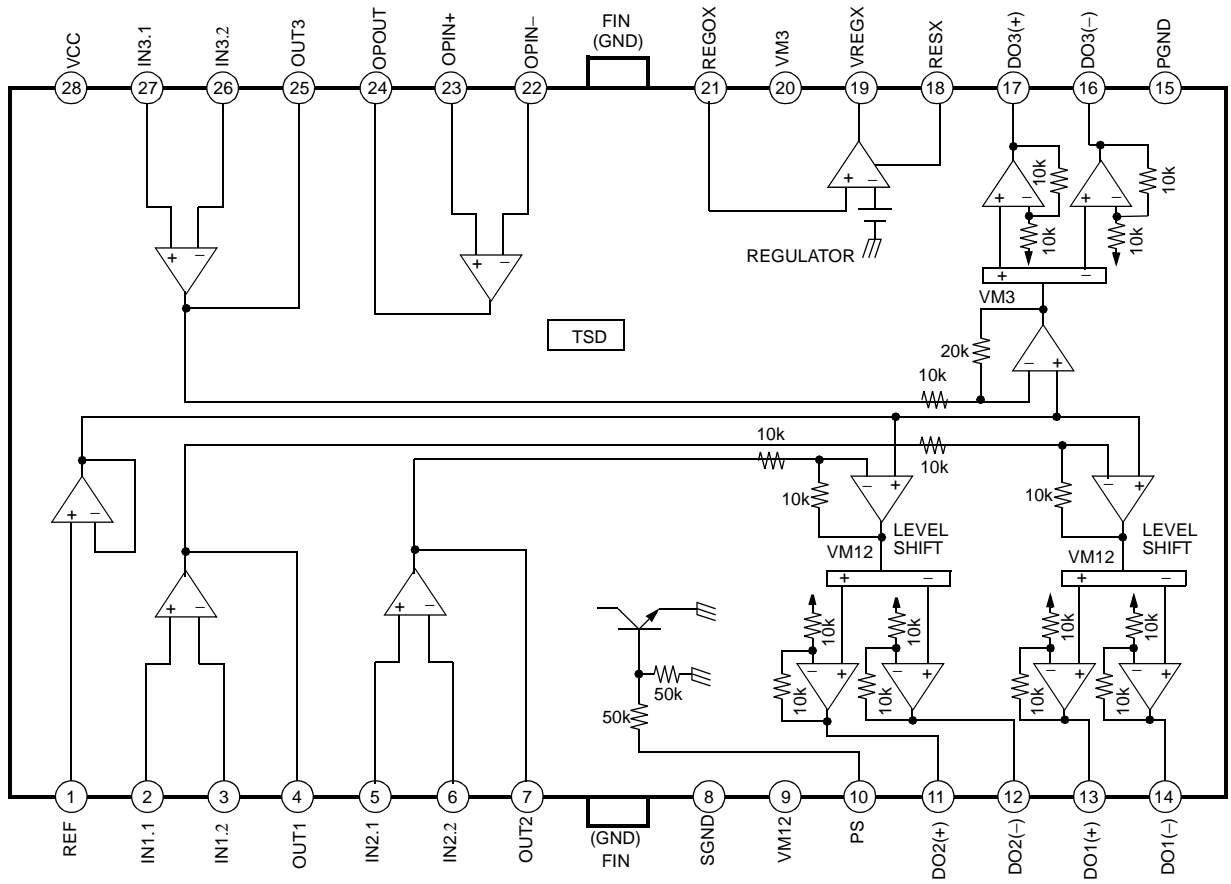

## Equivalent Circuits

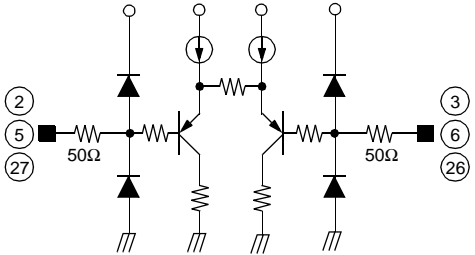
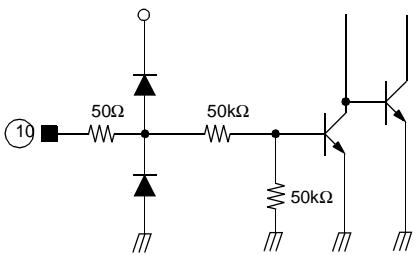
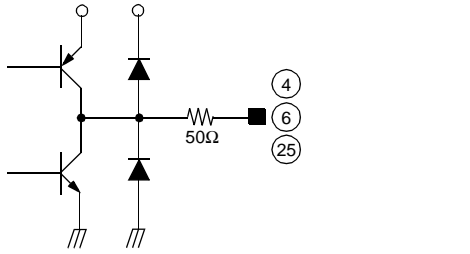
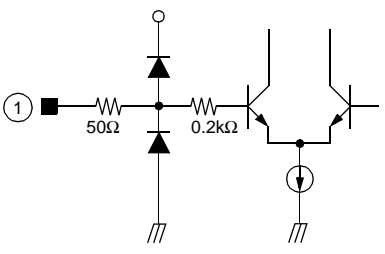
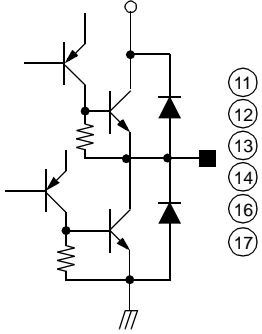
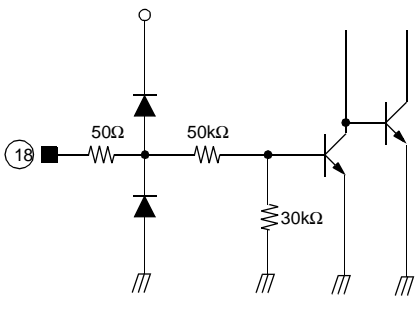
Error amp input	Power save input
	
Error amp output	Signal reference input
	
Power output	Regulator reset
	

## Equivalent Circuits (Continued)

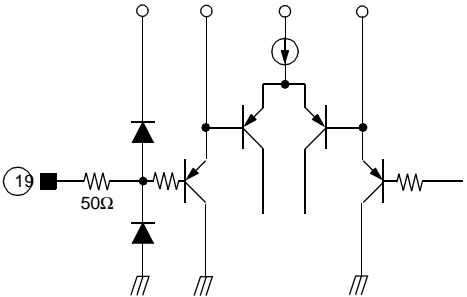
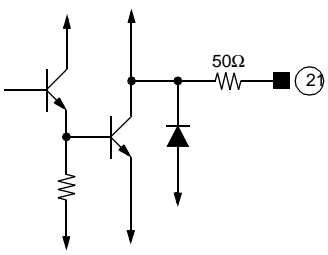
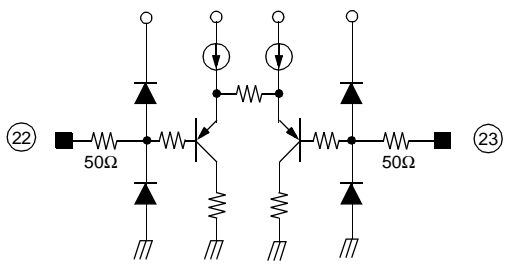
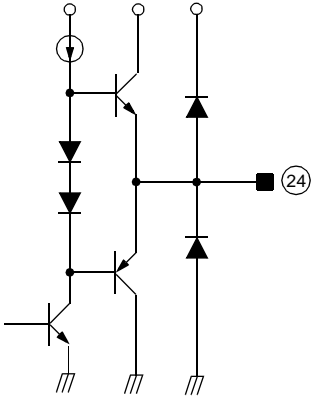
Regulator	Regulator output
 <p>The diagram shows the internal circuitry for pin 19. It features a 50Ω resistor connected to pin 19, followed by a network of transistors and diodes. The circuit is grounded at several points, indicated by ground symbols.</p>	 <p>The diagram shows the internal circuitry for the regulator output, pin 21. It includes a 50Ω resistor connected to pin 21, with a network of transistors and diodes below it. Ground symbols are present at the bottom of the circuit.</p>
General op amp input	General op amp output
 <p>The diagram shows the internal circuitry for general op amp input pins 22 and 23. Each pin is connected to a 50Ω resistor, which is then connected to a complex network of transistors and diodes. Ground symbols are shown at the bottom.</p>	 <p>The diagram shows the internal circuitry for the general op amp output, pin 24. It features a network of transistors and diodes connected to pin 24, with ground symbols at the bottom.</p>

## Absolute Maximum Ratings ( Ta=25°C)

Parameter	Symbol	Value	Unit
Maximum supply voltage	$V_{CCmax}$	7	V
Power dissipation	$P_D$	@1.4	W
Operating temperature range	$T_{OPR}$	-35 ~ +85	°C
Storage temperature range	$T_{STG}$	-55 ~ +150	°C

### Notes:

- When mounted on a 76.2mm × 114mm × 1.57mm PCB (Phenolic resin material).
- Power dissipation reduces 11.2mW / °C for using above Ta = 25°C
- Do not exceed PD and SOA (Safe operating area).

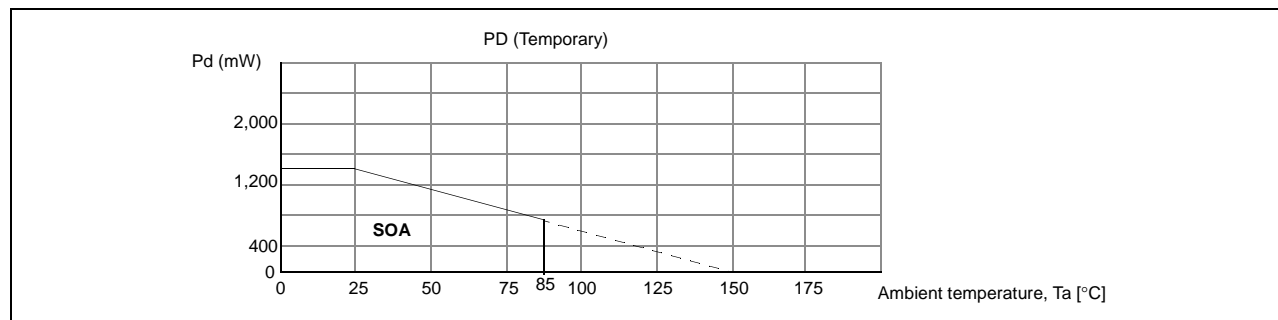

## Recommended Operating Conditions ( Ta=25°C)

Parameter	Symbol	Min.	Typ.	Max.	Unit
Supply voltage	VCC	4.5	-	5.5	V

## Electrical Characteristics

(Unless otherwise specified,  $T_a=25^{\circ}\text{C}$ ,  $V_{CC}=V_{M12}=V_{M3}=5\text{V}$ )

Parameter	Symbol	Conditions	Min.	Typ.	Max.	Unit
Quiescent current	$I_{CC}$	$V_{IN}=0\text{V}$	-	13	-	mA
Power save on current	$I_{PS}$	PS pin=GND	-	-	1	mA
Power save on voltage	$V_{PSon}$	-	-	-	0.5	V
Power save off voltage	$V_{PSoff}$	-	2	-	-	V
<b>BTL DRIVE CIRCUIT</b>						
Output offset voltage 1	$V_{OO1}$	$V_{IN}=2.5\text{V}$ (CH1,2)	-50	-	+50	mV
Output offset voltage 2	$V_{OO2}$	$V_{IN}=2.5\text{V}$ (CH3)	-60	-	+60	mV
Maximum output voltage 1	$V_{OM1}$	$V_{CC}=5\text{V}$ , $R_L=8\Omega$ (CH1, 2)	2.7	3.5	-	V
Maximum output voltage 2	$V_{OM2}$	$V_{CC}=5\text{V}$ , $R_L=24\Omega$ (CH3)	3	3.8	-	V
Closed loop voltage gain 1	$G_{VC1}$	$f=1\text{kHz}$ , $V_{IN}=0.1V_{RMS}$ (CH1, 2)	10.5	12	13.5	dB
Closed loop voltage gain 2	$G_{VC2}$	$f=1\text{kHz}$ , $V_{IN}=0.1V_{RMS}$ (CH3)	16	18	20	dB
Ripple rejection ratio	RR	$V_{IN}=0.1V_{RMS}$ , $f=120\text{Hz}$	-	60	-	dB
Slew rate	SR	$V_O=2\text{V}_{p-p}$ , $f=120\text{kHz}$	-	1	-	$\text{V}/\mu\text{s}$
<b>ERROR AMP CIRCUIT</b>						
Input offset voltage	$V_{OFOP}$	-	-20	-	+20	mV
Input bias current	$I_{BOP}$	-	-	-	300	nA
High level output voltage	$V_{OHOP}$	$V_{CC}=5\text{V}$ , $R_L=10\text{k}\Omega$	4.5	4.8	-	V
Low level output voltage	$V_{OLOP}$	$V_{CC}=5\text{V}$ , $R_L=10\text{k}\Omega$	-	0.2	0.5	V
Output sink current	$I_{SINK}$	$V_{CC}=5\text{V}$ , $R_L=1\text{k}\Omega$	1	3	-	mA
Output source current	$I_{SOURCE}$	$V_{CC}=5\text{V}$ , $R_L=1\text{k}\Omega$	1	3	-	mA
Slew rate	$SR_{OP}$	$f=120\text{kHz}$ , $2V_{p-p}$	-	1	-	$\text{V}/\mu\text{s}$
<b>GENERAL OP AMP CIRCUIT</b>						
Input offset voltage	$V_{OFOP}$	-	-20	-	+20	mV
Input bias current	$I_{BOP}$	-	-	-	300	nA
High level output voltage	$V_{OHOP}$	$V_{CC}=5\text{V}$ , $R_L=1\text{k}\Omega$	3	4	-	V
Low level output voltage	$V_{OLOP}$	$V_{CC}=5\text{V}$ , $R_L=1\text{k}\Omega$	-	1	1.3	V
Output sink current	$I_{SINK}$	$V_{CC}=5\text{V}$ , $R_L=50\Omega$	2	5	-	mA
Output source current	$I_{SOURCE}$	$V_{CC}=5\text{V}$ , $R_L=50\Omega$	2	5	-	mA
Open loop voltage gain	$G_{VO}$	$V_{IN}=-75\text{dB}$ , $f=1\text{kHz}$	-	75	-	dB
Ripple rejection ratio	$RR_{OP}$	$V_{IN}=-20\text{dB}$ , $f=120\text{Hz}$	-	65	-	dB
Slew rate	$SR_{OP}$	$f=120\text{kHz}$ , $2V_{p-p}$	-	1	-	$\text{V}/\mu\text{s}$
Common mode rejection ratio	CMRR	$V_{IN}=-20\text{dB}$ , $f=1\text{kHz}$	-	80	-	dB
<b>VARIABLE REGULATOR CIRCUIT</b>						
Regulator output voltage	$V_{REG}$	$I_L=100\text{mA}$	3.0	-	4.5	V
Load regulation	$\Delta V_{R1}$	$I_L=0 \rightarrow 200\text{mA}$	-40	-	10	mV
Line regulation	$\Delta V_{CC}$	$I_L=200\text{mA}$ , $V_{CC}=5 \rightarrow 8\text{V}$	-20	-	30	mV



## Application Information

### 1. Reference Input & Power Save Function

Pin 1 (REF) is a reference input pin.

- Reference input  
The applied voltage at the reference input pin must be between 1.5V and 3.5V, when  $V_{CC}=5V$ .
- Power save input  
The following input conditions must be satisfied for the power save function.

Power save on voltage	Below 0.5V	Power save function operation
Power save off voltage	Above 2V	Normal operation

### 2. Protection Function

Thermal shutdown (TSD)

- If the chip temperature rises above 175°C, the thermal shutdown (TSD) circuit is activated and the output circuit is in the mute state, that is off state. The TSD circuit has a temperature hysteresis of 25°C.

### 3. Regulator & Reset Function

The regulator configuration with the external components is illustrated in figure 1.

- The external circuit is composed of the KSB772 PNP transistor and a capacitor about 33μF, and two feedback resistors R1, R2.  
The capacitor operates both as a ripple eliminator and as a compensator of the feedback loop.
- The output voltage (REG OUT) is

$$V_{out} = \left(1 + \frac{R1}{R2}\right) \times 2.5$$

- When the voltage of pin18 (Vreset) is 0V, the regulator reset function is activated, and the output voltage (REG OUT) becomes 0V. Otherwise, if the voltage of pin 18 is 5V, the regulator operates properly.

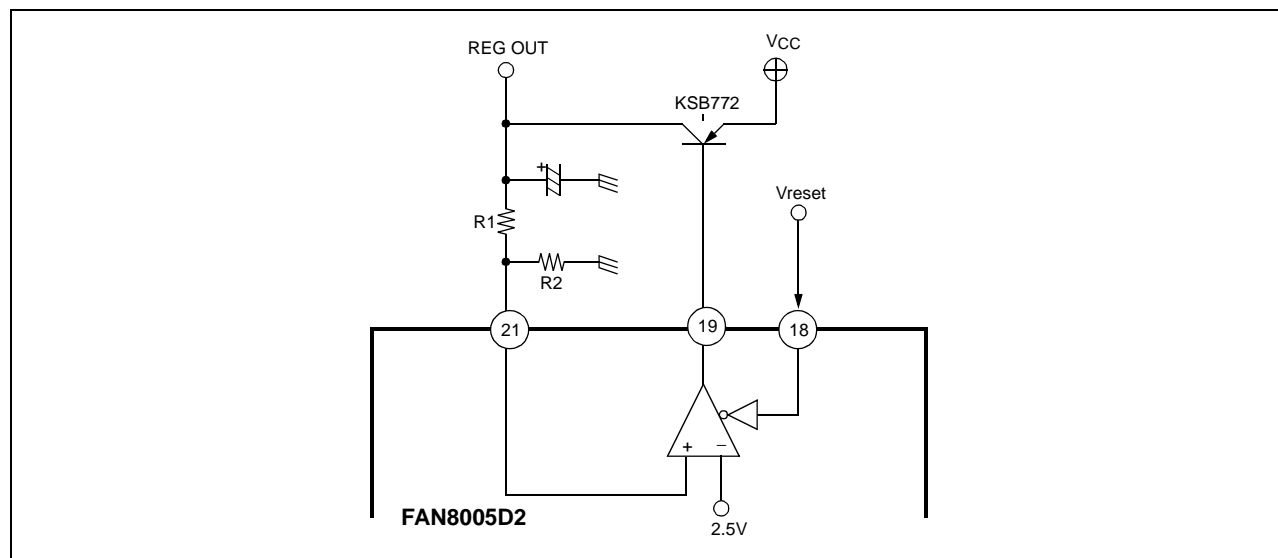
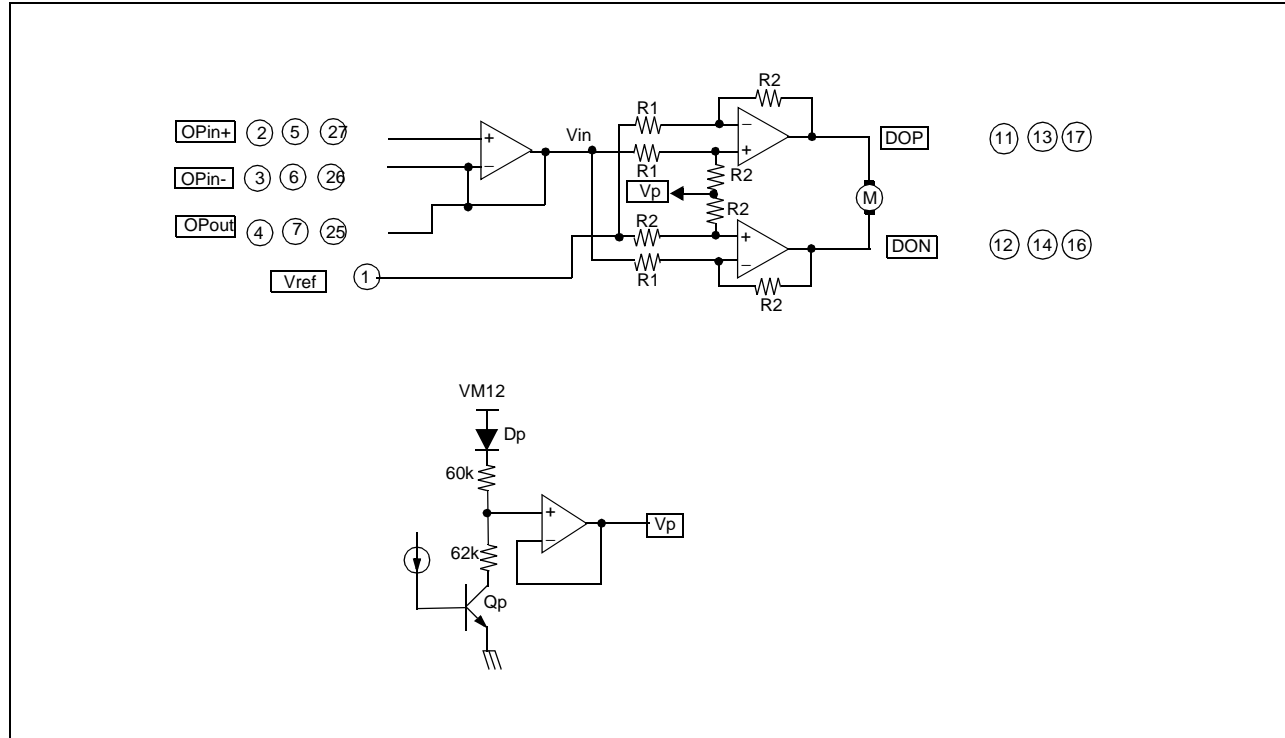

Figure 1. Regulator circuit

4. Focus / Tracking Actuator Sled Motor Drive Part



- The voltage, Vref is the reference voltage given by the external bias voltage of the pin 1.
- The input signal (Vin) through pins 3,6 and 26 are amplified one time and then fed to the output stage. (assume that input opamp was used as a buffer)
- The total closed loop voltage gain is as follows (assume that R2=2R1)

$$V_{in} = V_{ref} + \Delta V$$

$$DOP = V_p + 2\Delta V$$

$$DON = V_p - 2\Delta V$$

$$V_{out} = DOP - DON = 4\Delta V$$

$$Gain = 20 \log \frac{V_{out}}{\Delta V} = 20 \log 4 = 12 \text{ dB}$$

- To change the total closed loop voltage gain, Use the input opamp as an amplifier
- The output stage is the balanced transformerless (BTL) driver.
- The bias voltage Vp is expressed as ;

$$\begin{aligned}
 V_p &= (PVCC1 - VDp - V_{cesatQp}) \times \frac{62k}{60k + 62k} + V_{cesatQp} \\
 &= \frac{PVCC1 - VDp + V_{cesatQp}}{1.97} + V_{cesatQp} \quad \text{----- (1)}
 \end{aligned}$$

# Typical Performance Characteristics

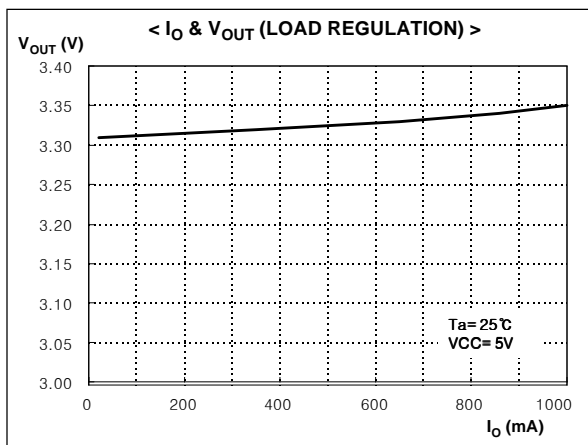
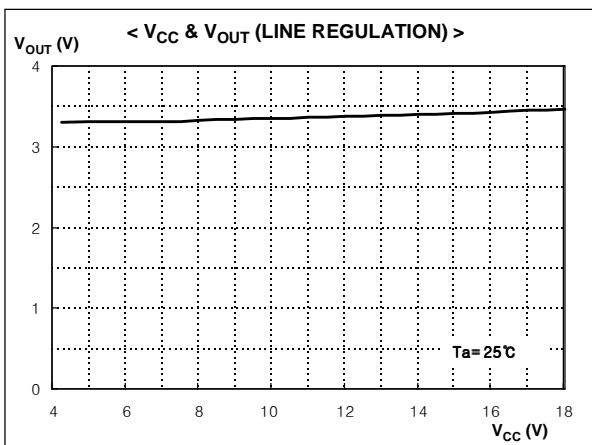
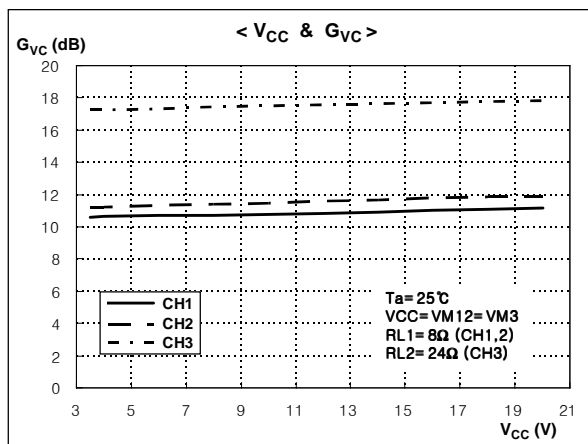
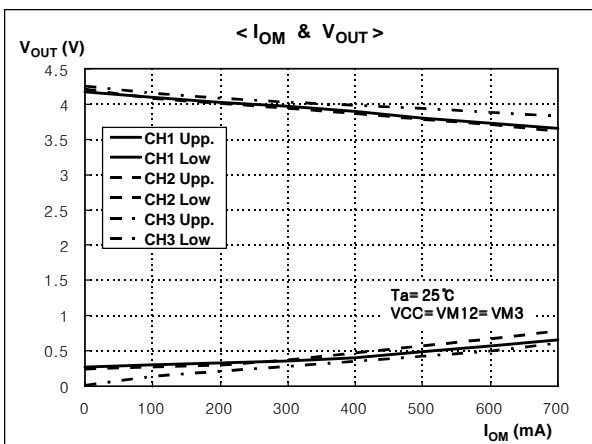
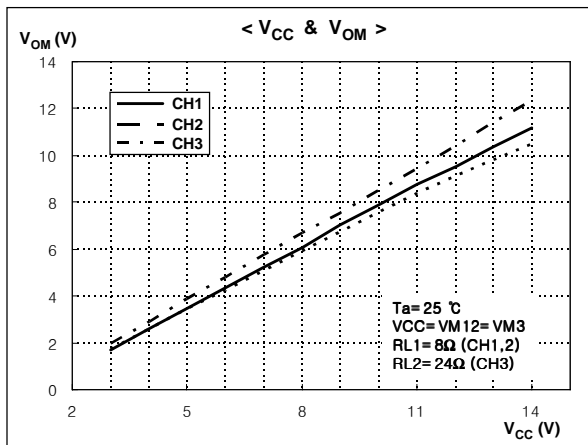
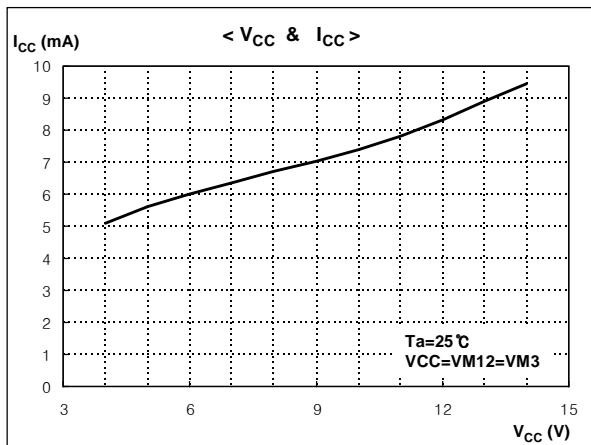

## Typical Performance Characteristics (Continued)

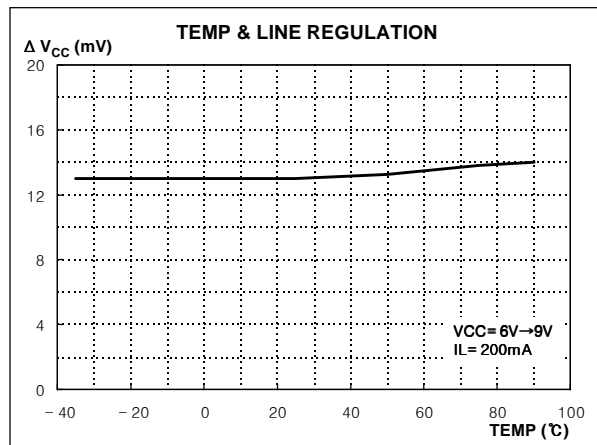
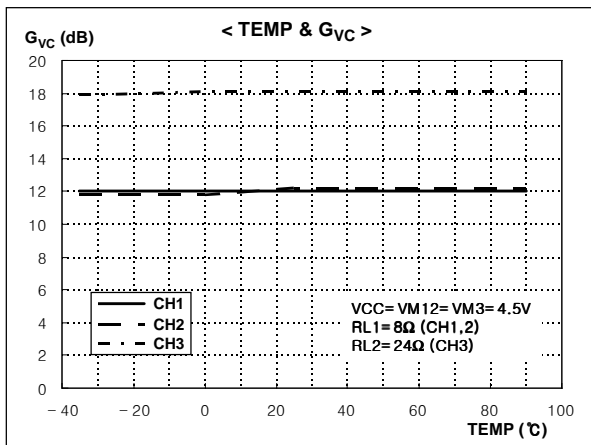
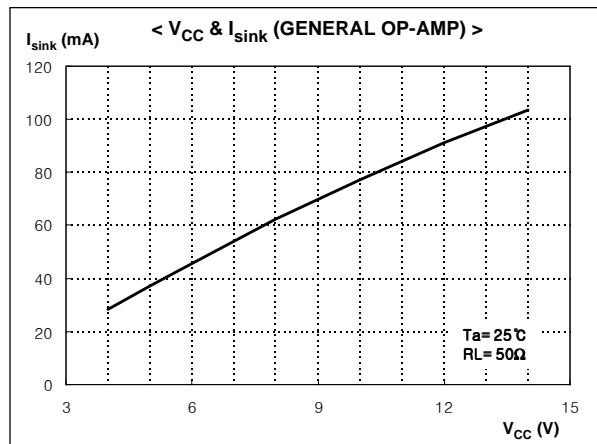
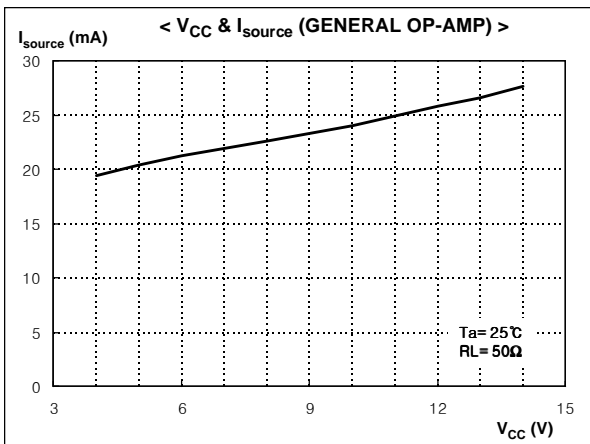
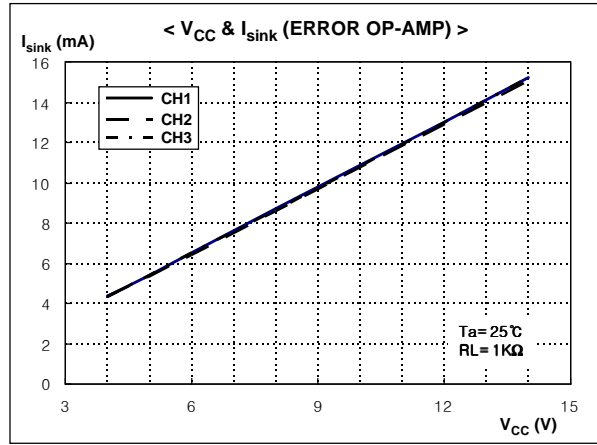
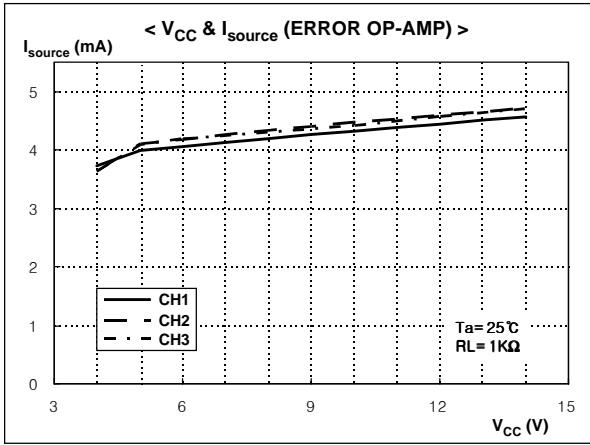

# Application Circuits 1

(Differential PWM control mode)

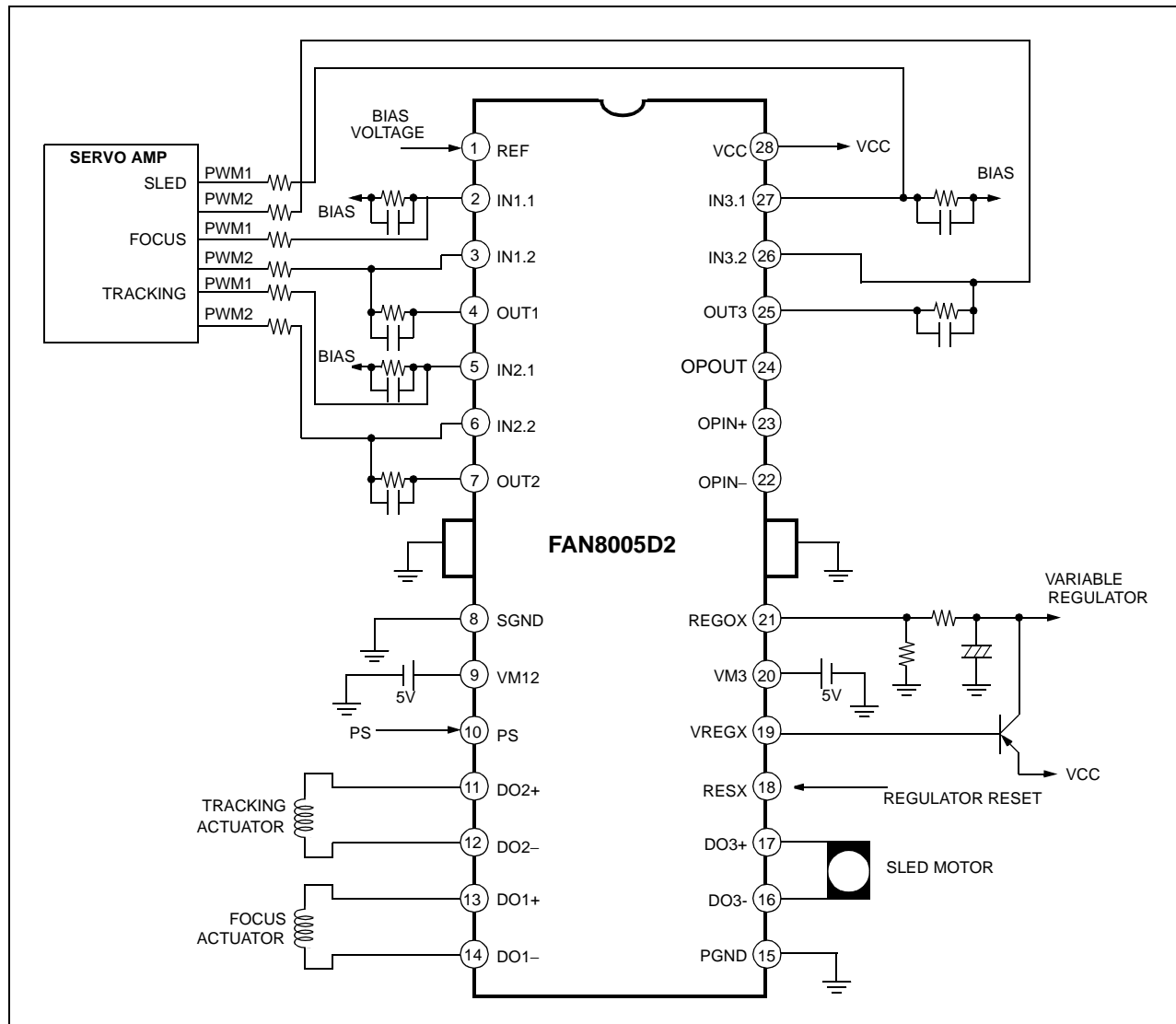

## Application Circuits 2

(Voltage control mode)

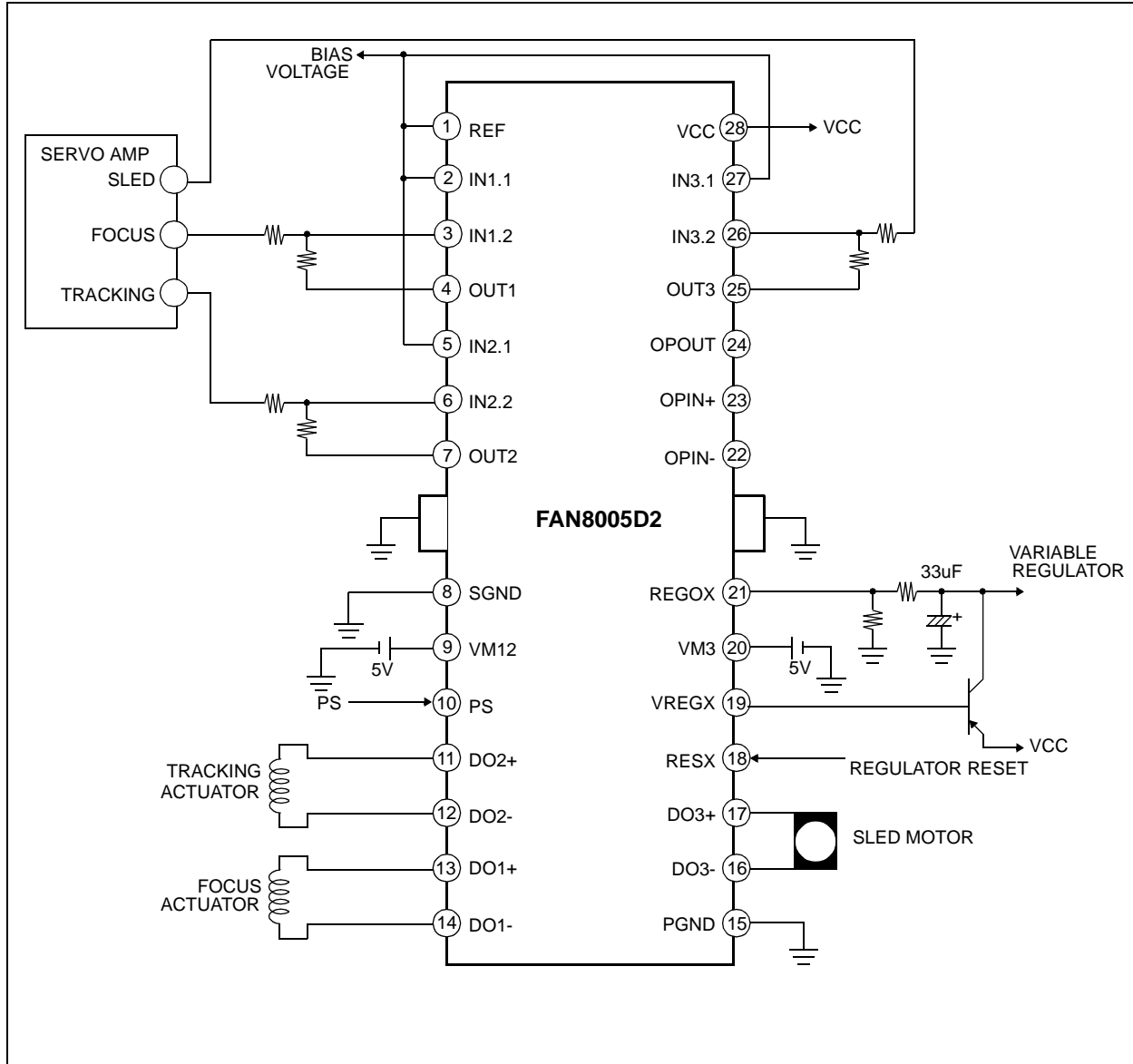



**DISCLAIMER**

FAIRCHILD SEMICONDUCTOR RESERVES THE RIGHT TO MAKE CHANGES WITHOUT FURTHER NOTICE TO ANY PRODUCTS HEREIN TO IMPROVE RELIABILITY, FUNCTION OR DESIGN. FAIRCHILD DOES NOT ASSUME ANY LIABILITY ARISING OUT OF THE APPLICATION OR USE OF ANY PRODUCT OR CIRCUIT DESCRIBED HEREIN; NEITHER DOES IT CONVEY ANY LICENSE UNDER ITS PATENT RIGHTS, NOR THE RIGHTS OF OTHERS.

**LIFE SUPPORT POLICY**

FAIRCHILD'S PRODUCTS ARE NOT AUTHORIZED FOR USE AS CRITICAL COMPONENTS IN LIFE SUPPORT DEVICES OR SYSTEMS WITHOUT THE EXPRESS WRITTEN APPROVAL OF THE PRESIDENT OF FAIRCHILD SEMICONDUCTOR CORPORATION. As used herein:

1. Life support devices or systems are devices or systems which, (a) are intended for surgical implant into the body, or (b) support or sustain life, and (c) whose failure to perform when properly used in accordance with instructions for use provided in the labeling, can be reasonably expected to result in a significant injury of the user.
2. A critical component in any component of a life support device or system whose failure to perform can be reasonably expected to cause the failure of the life support device or system, or to affect its safety or effectiveness.