

74F138 1-of-8 Decoder/Demultiplexer

General Description

The F138 is a high-speed 1-of-8 decoder/demultiplexer. This device is ideally suited for high-speed bipolar memory chip select address decoding. The multiple input enable allow parallel expansion to a 1-of-24 decoder using just three F138 devices or a 1-of-32 decoder using four F138 devices and one inverter.

Features

- Demultiplexing capability
- Multiple input enable for easy expansion
- Active LOW mutually exclusive outputs
- Guaranteed 4000V minimum ESD protection

Ordering Code:

Commercial	Package Number	Package Description
74F138PC	N16E	16-Lead (0.300" Wide) Molded Dual-In-Line
74F138SC (Note 1)	M16A	16-Lead (0.150" Wide) Molded Small Outline, JEDEC
74F138SJ (Note 1)	M16D	16-Lead (0.300" Wide) Molded Small Outline, EIAJ

Note 1: Devices also available in 13" reel. Use suffix = SCX and SJX.

Logic Symbols

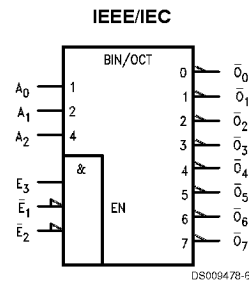
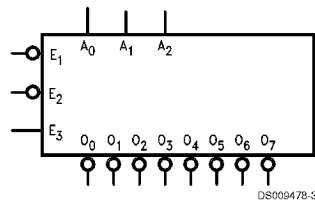

Connection Diagram

Pin Assignment for DIP and SOIC

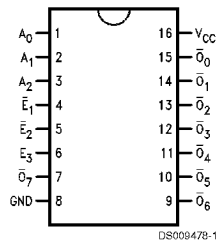

Unit Loading/Fan Out

Pin Names	Description	U.L. HIGH/LOW	Input I_{IH}/I_{IL} Output I_{OH}/I_{OL}
A_0 – A_2	Address Inputs	1.0/1.0	20 μ A/–0.6 mA
\bar{E}_1, \bar{E}_2	Enable Inputs (Active LOW)	1.0/1.0	20 μ A/–0.6 mA
E_3	Enable Input (Active HIGH)	1.0/1.0	20 μ A/–0.6 mA
\bar{O}_0 – \bar{O}_7	Outputs (Active LOW)	50/33.3	–1 mA/20 mA

Functional Description

The F138 high-speed 1-of-8 decoder/demultiplexer accepts three binary weighted inputs (A_0, A_1, A_2) and, when enabled, provides eight mutually exclusive active LOW outputs (\bar{O}_0 – \bar{O}_7). The F138 features three Enable inputs, two active LOW (\bar{E}_1, \bar{E}_2) and one active HIGH (E_3). All outputs will be HIGH unless \bar{E}_1 and \bar{E}_2 are LOW and E_3 is HIGH. This multiple enable function allows easy parallel expansion of the

device to a 1-of-32 (5 lines to 32 lines) decoder with just four F138 devices and one inverter (See Figure 1). The F138 can be used as an 8-output demultiplexer by using one of the active LOW Enable inputs as the data input and the other Enable inputs as strobes. The Enable inputs which are not used must be permanently tied to their appropriate active HIGH or active LOW state.

Truth Table

Inputs						Outputs							
\bar{E}_1	\bar{E}_2	E_3	A_0	A_1	A_2	\bar{O}_0	\bar{O}_1	\bar{O}_2	\bar{O}_3	\bar{O}_4	\bar{O}_5	\bar{O}_6	\bar{O}_7
H	X	X	X	X	X	H	H	H	H	H	H	H	H
X	H	X	X	X	X	H	H	H	H	H	H	H	H
X	X	L	X	X	X	H	H	H	H	H	H	H	H
L	L	H	L	L	L	L	H	H	H	H	H	H	H
L	L	H	H	L	L	H	L	H	H	H	H	H	H
L	L	H	L	H	L	H	H	L	H	H	H	H	H
L	L	H	H	H	L	H	H	H	L	H	H	H	H
L	L	H	L	L	H	H	H	H	H	L	H	H	H
L	L	H	L	H	H	H	H	H	H	H	L	H	H
L	L	H	H	H	H	H	H	H	H	H	H	L	H
L	L	H	H	H	H	H	H	H	H	H	H	H	L

H = HIGH Voltage Level
L = LOW Voltage Level
X = Immaterial

Logic Diagram

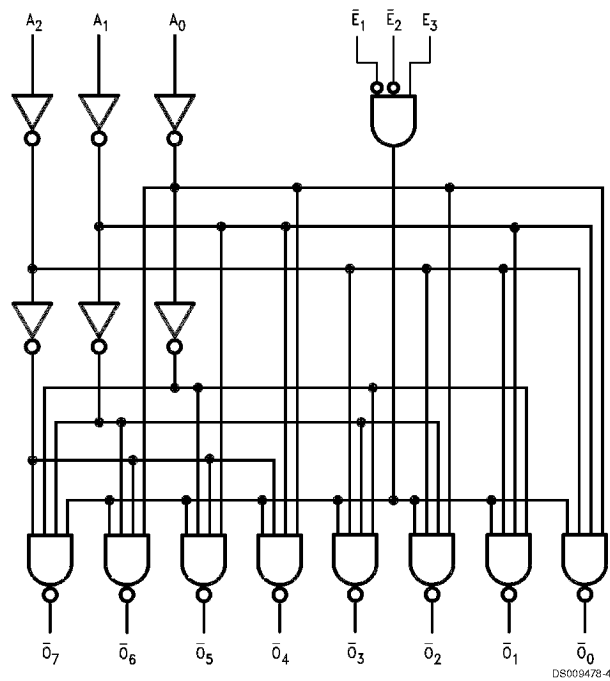

Please note that this diagram is provided only for the understanding of logic operations and should not be used to estimate propagation delays.

Absolute Maximum Ratings (Note 2)

Storage Temperature	-65°C to +150°C
Ambient Temperature under Bias	-55°C to +125°C
Junction Temperature under Bias	-55°C to +175°C
Plastic	-55°C to +150°C
V _{CC} Pin Potential to Ground Pin	-0.5V to +7.0V
Input Voltage (Note 3)	-0.5V to +7.0V
Input Current (Note 3)	-30 mA to +5.0 mA
Voltage Applied to Output in HIGH State (with V _{CC} = 0V)	
Standard Output	-0.5V to V _{CC}
3-STATE Output	-0.5V to +5.5V
Current Applied to Output	

in LOW State (Max) twice the rated I_{OL} (mA)
ESD Last Passing Voltage (Min) 4000V

Recommended Operating Conditions

Free Air Ambient Temperature	
Commercial	0°C to +70°C
Supply Voltage	
Commercial	+4.5V to +5.5V

Note 2: Absolute maximum ratings are values beyond which the device may be damaged or have its useful life impaired. Functional operation under these conditions is not implied.

Note 3: Either voltage limit or current limit is sufficient to protect inputs.

DC Electrical Characteristics

Symbol	Parameter	Min	Typ	Max	Units	V _{CC}	Conditions
V _{IH}	Input HIGH Voltage	2.0			V		Recognized as a HIGH Signal
V _{IL}	Input LOW Voltage			0.8	V		Recognized as a LOW Signal
V _{CD}	Input Clamp Diode Voltage			-1.2	V	Min	I _{IN} = -18 mA
V _{OH}	Output HIGH Voltage	10% V _{CC} 5% V _{CC}	2.5 2.7		V	Min	I _{OH} = -1 mA I _{OH} = -1 mA
V _{OL}	Output LOW Voltage	10% V _{CC}		0.5	V	Min	I _{OL} = 20 mA
I _{IH}	Input HIGH Current			5.0	μA	Max	V _{IN} = 2.7V
I _{BVI}	Input HIGH Current Breakdown Test			7.0	μA	Max	V _{IN} = 7.0V
I _{CEX}	Output HIGH Leakage Current			50	μA	Max	V _{OUT} = V _{CC}
V _{ID}	Input Leakage Test	4.75			V	0.0	I _{ID} = 1.9 μA All Other Pins Grounded
I _{OD}	Output Leakage Circuit Current			3.75	μA	0.0	V _{IOD} = 150 mV All Other Pins Grounded
I _{IL}	Input LOW Current			-0.6	mA	Max	V _{IN} = 0.5V
I _{OS}	Output Short-Circuit Current	-60		-150	mA	Max	V _{OUT} = 0V
I _{CCH}	Power Supply Current		13	20	mA	Max	V _O = HIGH
I _{CCL}	Power Supply Current		13	20	mA	Max	V _O = LOW

AC Electrical Characteristics

Symbol	Parameter	74F			74F		Units
		T _A = +25°C V _{CC} = +5.0V C _L = 50 pF			T _A , V _{CC} = Com C _L = 50 pF		
		Min	Typ	Max	Min	Max	
t _{PLH}	Propagation Delay	3.5	5.6	7.5	3.5	8.5	ns
t _{PHL}	A _n to \bar{O}_n	4.0	6.1	8.0	4.0	9.0	
t _{PLH}	Propagation Delay	3.5	5.4	7.0	3.5	8.0	ns
t _{PHL}	\bar{E}_1 or \bar{E}_2 to \bar{O}_n	3.0	5.3	7.0	3.0	7.5	
t _{PLH}	Propagation Delay	4.0	6.2	8.0	4.0	9.0	ns
t _{PHL}	E ₃ to \bar{O}_n	3.5	5.6	7.5	3.5	8.5	

AC Electrical Characteristics (Continued)

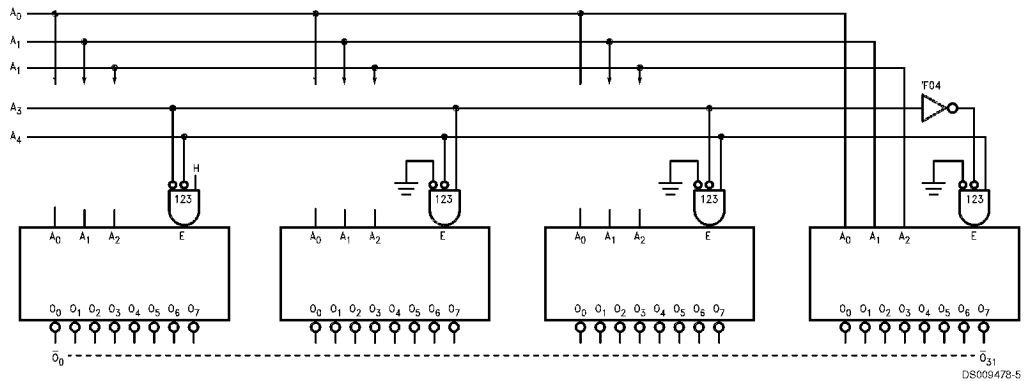
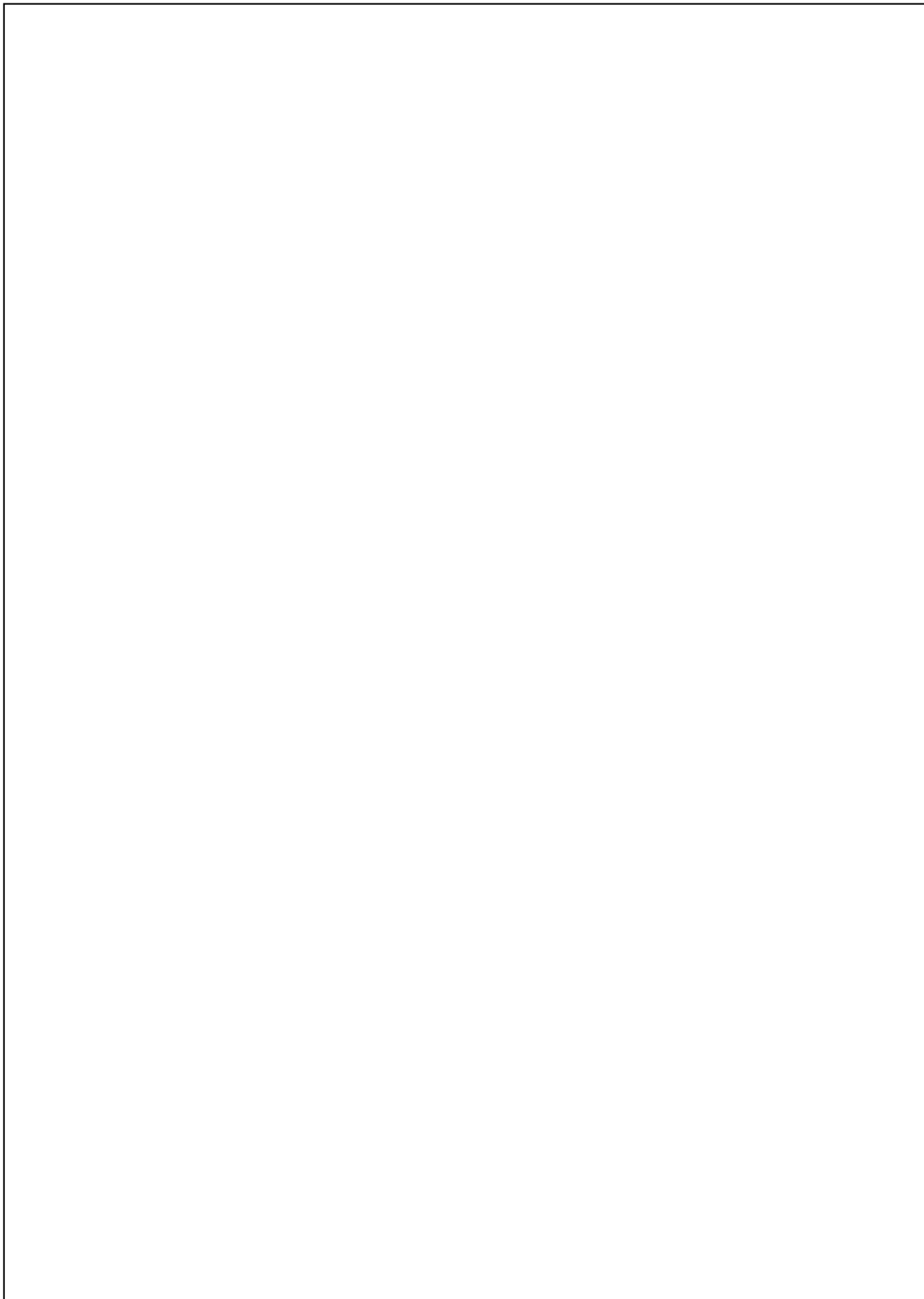
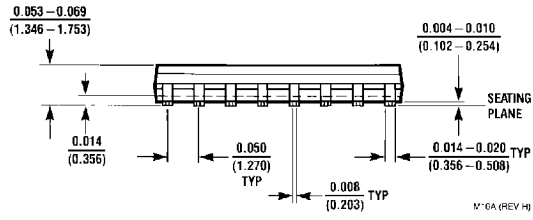
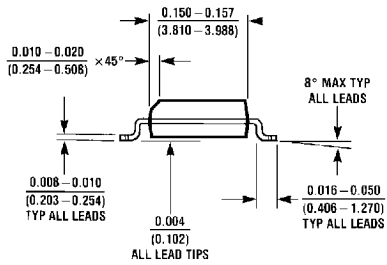
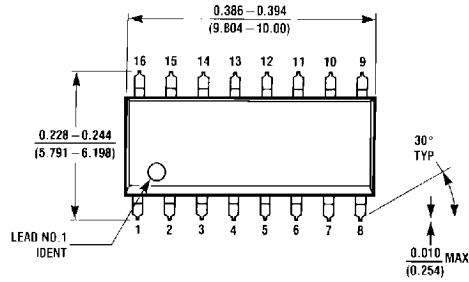

FIGURE 1. Expansion to 1-of-32 Decoding

DS009478-5



Physical Dimensions inches (millimeters) unless otherwise noted



**16-Lead (0.150" Wide) Molded Small Outline Package, JEDEC (S)
Package Number M16A**

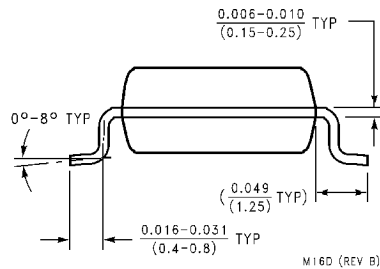
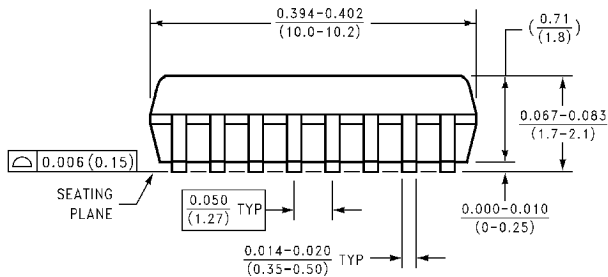
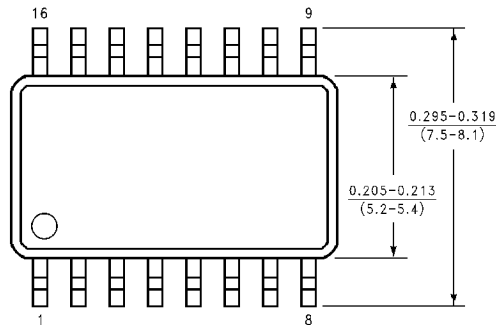

**16-Lead (0.300" Wide) Molded Small Outline Package, EIAJ (SJ)
Package Number M16D**

Physical Dimensions inches (millimeters) unless otherwise noted (Continued)

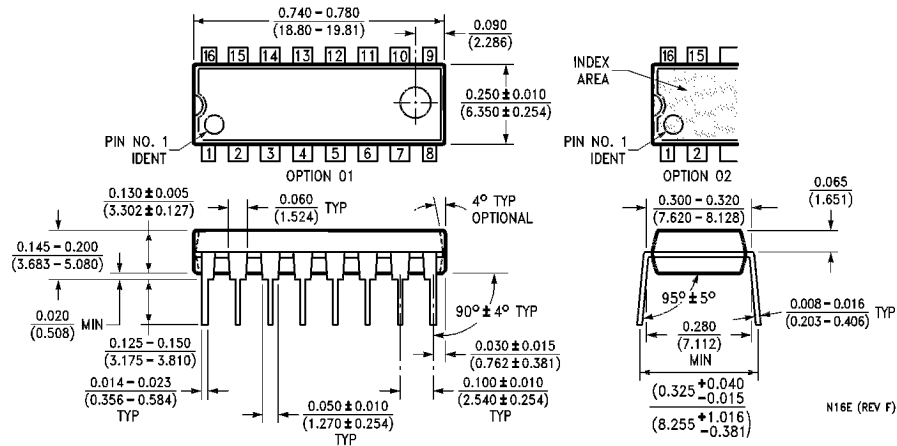

**16-Lead (0.300" Wide) Molded Dual-In-Line Package (P)
Package Number N16E**

LIFE SUPPORT POLICY

FAIRCHILD'S PRODUCTS ARE NOT AUTHORIZED FOR USE AS CRITICAL COMPONENTS IN LIFE SUPPORT DEVICES OR SYSTEMS WITHOUT THE EXPRESS WRITTEN APPROVAL OF THE PRESIDENT OF FAIRCHILD SEMICONDUCTOR CORPORATION. As used herein:

1. Life support devices or systems are devices or systems which, (a) are intended for surgical implant into the body, or (b) support or sustain life, and (c) whose failure to perform when properly used in accordance with instructions for use provided in the labeling, can be reasonably expected to result in a significant injury to the user.
2. A critical component in any component of a life support device or system whose failure to perform can be reasonably expected to cause the failure of the life support device or system, or to affect its safety or effectiveness.

Fairchild Semiconductor Corporation Americas
Customer Response Center
Tel: 1-888-522-5372

Fairchild Semiconductor Europe
Fax: +49 (0) 1 80-530 85 86
Email: europe.support@nsc.com
Deutsch Tel: +49 (0) 8 141-35-0
English Tel: +44 (0) 1 793-85-68-56
Italy Tel: +39 (0) 2 57 5631

Fairchild Semiconductor Hong Kong Ltd.
13th Floor, Straight Block,
Ocean Centre, 5 Canton Rd.
Tsimshatsui, Kowloon
Hong Kong
Tel: +852 2737-7200
Fax: +852 2314-0061

National Semiconductor Japan Ltd.
Tel: 81-3-5620-6175
Fax: 81-3-5620-6179

www.fairchildsemi.com

Fairchild does not assume any responsibility for use of any circuitry described, no circuit patent licenses are implied and Fairchild reserves the right at any time without notice to change said circuitry and specifications.