



MODEL NO: 11-21 URC/TR8  
**1206 Package Chip LEDs with Inner Lens**

Device Number : DSE-111-020 REV. 1.2

ECN : \_\_\_\_\_ Page: 1/8

**Features :**

- Package in 8mm tape on 7" diameter reel.
- Compatible with automatic placement equipment.
- Compatible with infrared and vapor phase reflow solder process.
- Mono-color type.

**Descriptions :**

- The 11-21 SMD Taping is much smaller than lead frame type components, thus enable smaller board size, higher packing density, reduced storage space and finally smaller equipment to be obtained.
- Besides, light weight makes them ideal for miniature applications, etc.

**Applications :**

- Automotive: backlighting in dashboard and switch.
- Telecommunication: indicator and backlighting in telephone and fax.
- Flat backlight for LCD, switch and symbol.
- General use.

**Package Dimensions :**

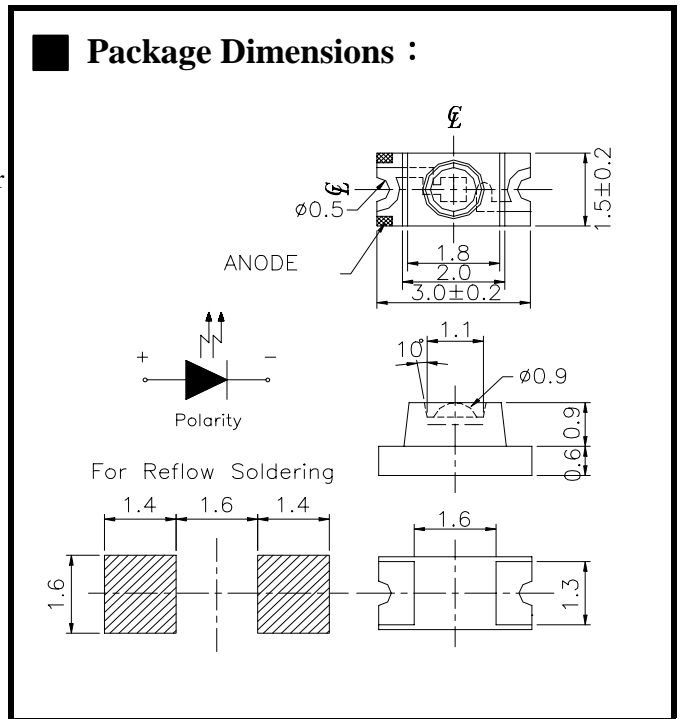

**Notes :**

Tolerances Unless Dimension  $\pm 0.1\text{mm}$   
 Angle  $\pm 0.5^\circ$   
 Unit = mm

PART NO	Chip		Lens Color
	Material	Emitted Color	
11-21 URC/TR8	GaAlAs	Super Red	Water Clear

Office: NO. 25, Lane 76, Sec.3, Chung Yang Rd., Tucheng 236, Taipei, Taiwan, R.O.C.

TEL: 886-2-2267-2000, 2267-9936

FAX: 886-2-2267-6244, 2267-6189, 2267-6306

http: //www.everlight.com



MODEL NO: 11-21 URC/TR8  
*1206 Package Chip LEDs with Inner Lens*

Device Number : DSE-111-020 REV. 1.2

ECN : \_\_\_\_\_ Page: 2/8

■ Package Dimensions :

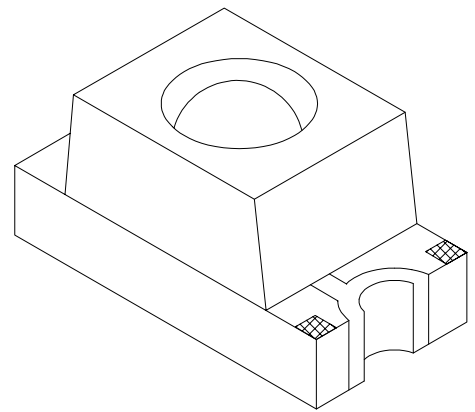
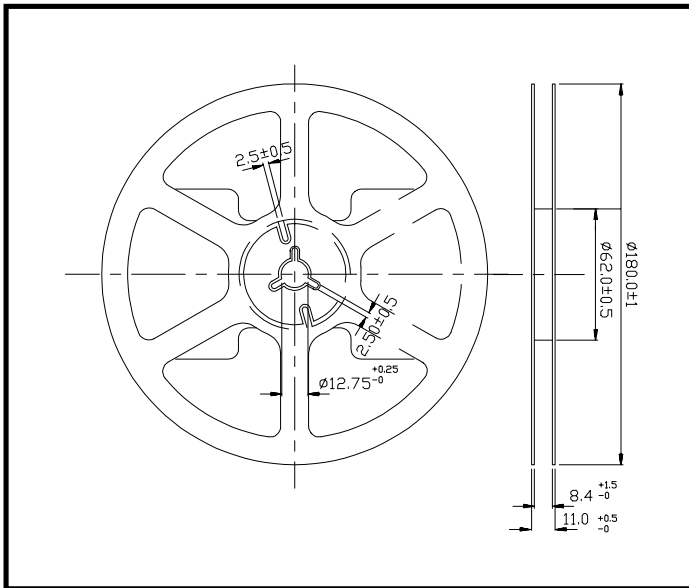

■ Loaded quantity per reel 2000 PCS/reel :

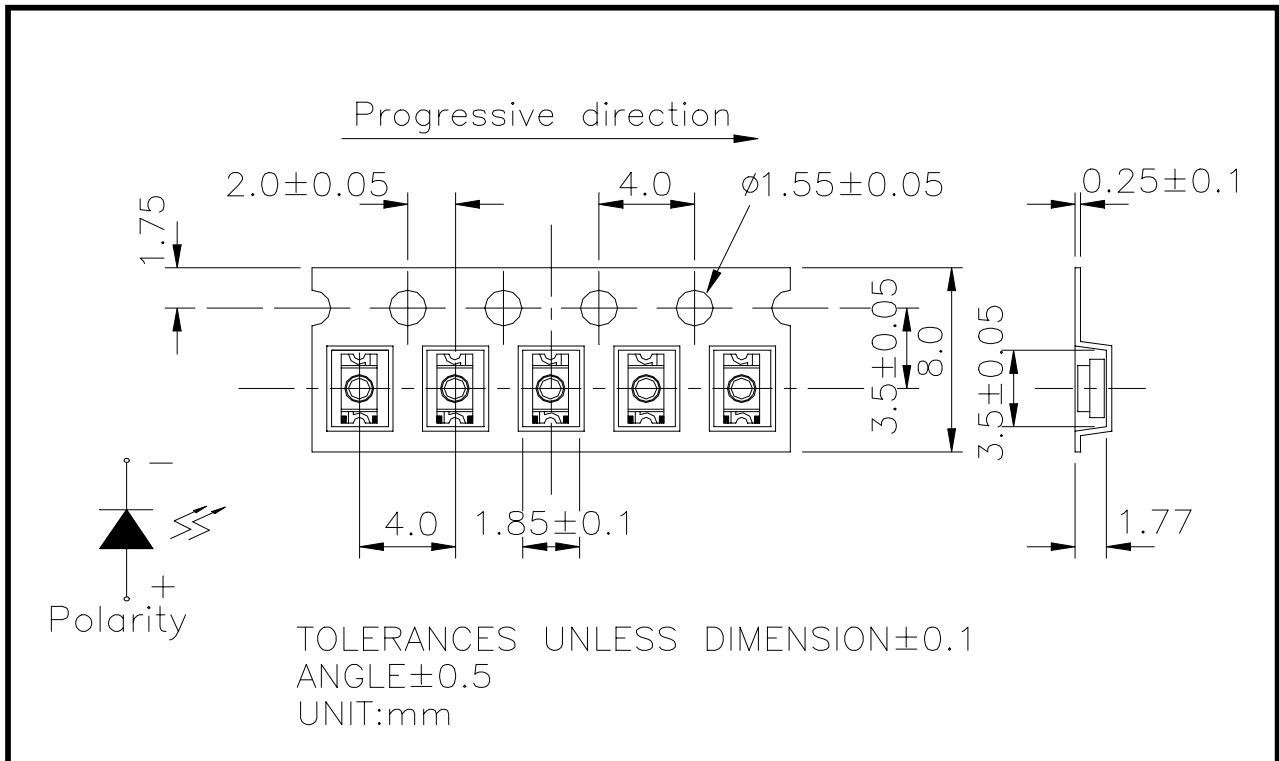

MODEL NO: 11-21 URC/TR8  
*1206 Package Chip LEDs with Inner Lens*Device Number : DSE-111-020 REV. 1.2ECN : \_\_\_\_\_ Page: 3/8**■ Absolute Maximum Ratings at Ta = 25°C**

Parameter	Symbol	Rating	Unit
Reverse Voltage	V <sub>R</sub>	5	V
Forward Current	I <sub>F</sub>	40	mA
Operating Temperature	Topr	-40 ~ +85	°C
Storage Temperature	Tstg	-40 ~ +90	°C
Soldering Temperature	Tsol	260 (for 5 second)	°C
Power Dissipation	Pd	110	mW
Peak Forward Current(Duty 1/10 @ 1KHz)	I <sub>F</sub> (Peak)	180	mA

**■ Electronic Optical Characteristics :**

Parameter	Symb	Min.	Typ.	Max.	Unit	Condition
Luminous Intensity	I <sub>v</sub>	55.0	91.5	-----	mcd	I <sub>F</sub> =20mA
Viewing Angle	2θ	-----	20	-----	deg	I <sub>F</sub> =20mA
Peak Wavelength	λ <sub>p</sub>	-----	660	-----	nm	I <sub>F</sub> =20mA
Dominant Wavelength	λ <sub>d</sub>	-----	643	-----	nm	I <sub>F</sub> =20mA
Spectrum Radiation Bandwidth	Δλ	-----	20	-----	nm	I <sub>F</sub> =20mA
Forward Voltage	V <sub>F</sub>	1.5	1.7	2.4	V	I <sub>F</sub> =20mA
Reverse Current	I <sub>R</sub>	-----	-----	10	μA	V <sub>R</sub> =5V



MODEL NO: 11-21 URC/TR8  
**1206 Package Chip LEDs with Inner Lens**

Device Number : DSE-111-020 REV. 1.2

ECN : \_\_\_\_\_ Page: 4/8

■ **Typical Electro-Optical Characteristic Curves :**

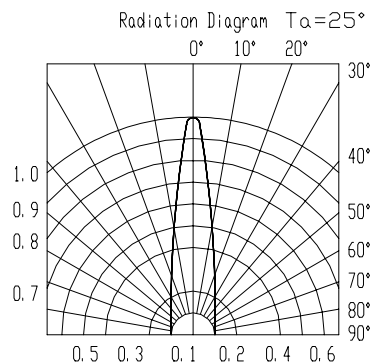
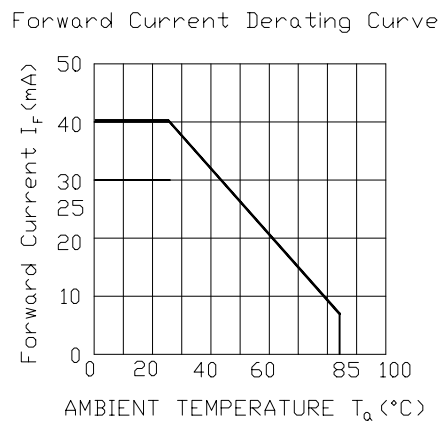
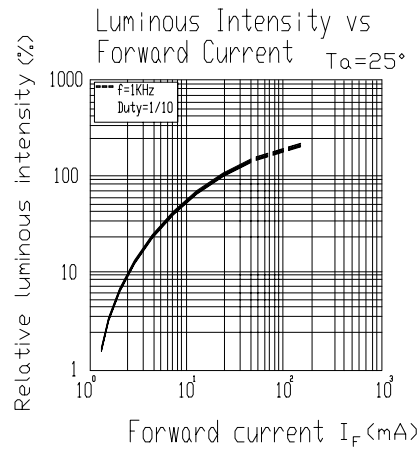
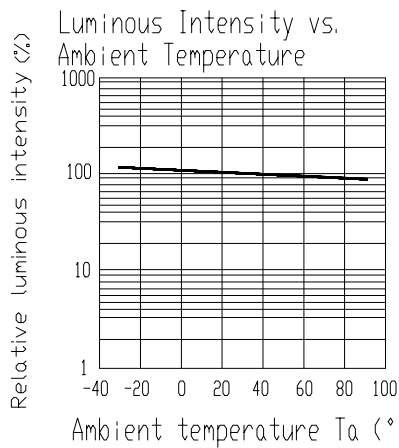
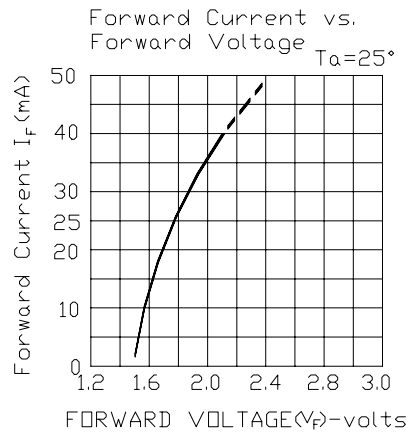
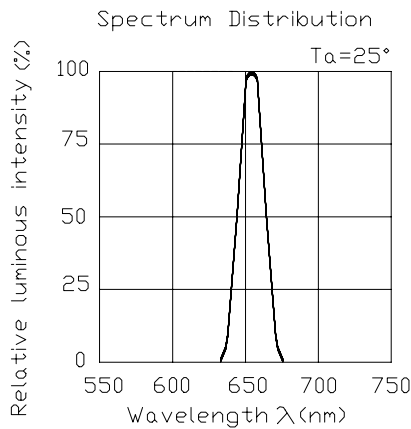



MODEL NO: 11-21 URC/TR8  
**1206 Package Chip LEDs with Inner Lens**

Device Number : DSE-111-020 REV. 1.2

ECN : \_\_\_\_\_ Page: 5/8

■ Reliability Test Items And Conditions :

NO	Item	Test Conditions	Test Hours/Cycle	Sample Size	Ac/Re
1	Solder Heat	TEMP : 260°C ± 5 °C	5 SEC	76 PCS	0/1
2	Temperature Cycle	H : +85°C 30min ∫ 5 min L : -55°C 30min	50 CYCLES	76 PCS	0/1
3	Thermal Shock	H : +100°C 5min ∫ 10 sec L : -10°C 5min	50 CYCLES	76 PCS	0/1
4	High Temperature Storage	TEMP : 100°C	1000 HRS	76 PCS	0/1
5	Low Temperature Storage	TEMP : -55°C	1000 HRS	76 PCS	0/1
6	DC Operating Life	I <sub>F</sub> = 20 mA	1000 HRS	76 PCS	0/1
7	High Temperature / High Humidity	85°C/85% RH	1000 HRS	76 PCS	0/1



MODEL NO: 11-21 URC/TR8  
**1206 Package Chip LEDs with Inner Lens**

Device Number : DSE-111-020 REV. 1.2

ECN : \_\_\_\_\_ Page: 6/8

■ **Test Circuit :**

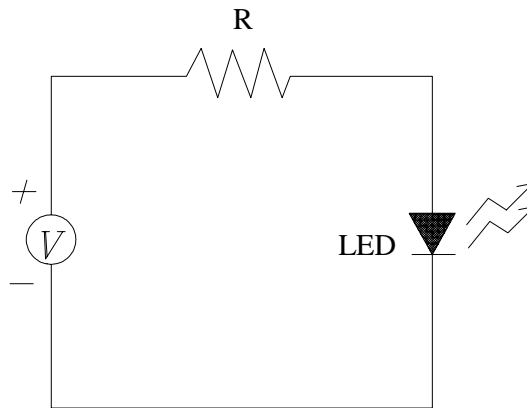

■ **Precautions For Use :**

1. Over-current-proof

Customer must apply resistors for protection , otherwise slight voltage shift will cause big current change ( Burn out will happen ).

2. Storage time

2.1 The operation of temperature and R.H. are :  $5^{\circ}\text{C} \sim 35^{\circ}\text{C}$  , R.H.60%.

2.2 Once the package is opened, the products should be used within a week.

Otherwise, they should be kept in a damp proof box with desiccant agent.

Considering the tape life , we suggest our customers to use our products within a year(from production date).

2.3 If opened more than one week in an atmosphere  $5^{\circ}\text{C} \sim 35^{\circ}\text{C}$  , R.H.60% , they should be treated at  $60^{\circ}\text{C} \pm 5^{\circ}\text{C}$  for 15hrs.

2.4 When you discover that the desiccant in the package has a pink color (normal = blue) , you should treat them in the same conditions as 2.3.



MODEL NO: 11-21 URC/TR8  
**1206 Package Chip LEDs with Inner Lens**

Device Number : DSE-111-020 REV. 1.2

ECN : \_\_\_\_\_ Page: 7/8

■ **Soldering heat reliability ( DIP ) :**

Please refer to the following figure :

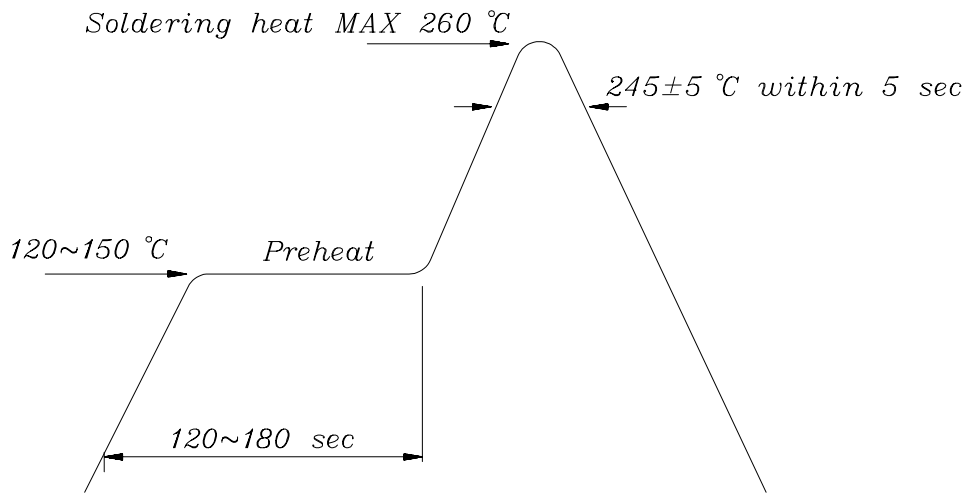

■ **Soldering Iron :**

Basic spec is  $\leq 5$  sec when 260°C. If temperature is higher, time should be shorter (+10°C → -1sec). Power dissipation of iron should be smaller than 15 W , and temperature should be controllable. Surface temperature of the device should be under 230 °C .

■ **Rework :**

1. Customer must finish rework within 5 sec under 260°C.
2. The head of iron can not touch copper foil.
3. Twin-head type is preferred.

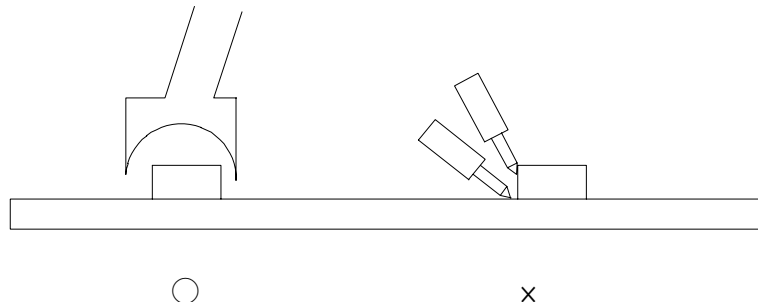



MODEL NO: 11-21 URC/TR8  
*1206 Package Chip LEDs with Inner Lens*

Device Number : DSE-111-020 REV. 1.2

ECN : \_\_\_\_\_ Page: 8/8

■ Reflow Temp / Time :

