



MODEL NO: 12-215UBGC/TR8

Device Number : DSE-125-020 REV. 1.0

Chip LEDs with Right Angle Lens

ECN : Page: 1/8

Features :

- Package in 8mm tape on 7" diameter reel.
- Compatible with automatic placement equipment.
- Compatible with infrared and vapor phase reflow solder process.
- Mono-color type.

Description :

- The 12-215 SMD Taping is much smaller than leaded components, thus enable smaller board size, higher packing density, reduced storage space and finally smaller equipment to be obtained.
- Besides, lightweight makes them ideal for miniature application, etc.

Applications :

- Automotive: backlighting in dashboard and switch.
- Telecommunication: indicator and backlighting in telephone and fax.
- Flat backlight for LCD, switch and symbol.
- General use.

Package Dimension :

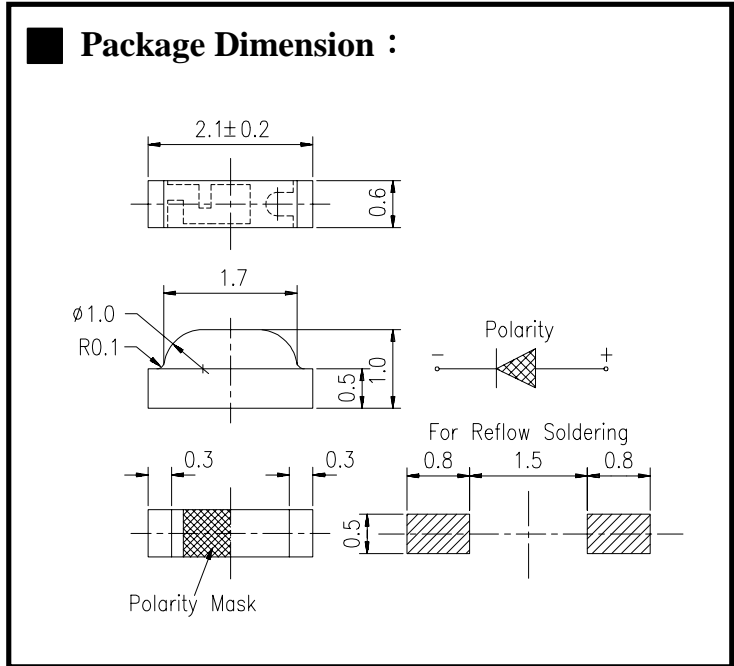

Notes :

Tolerances Unless Dimension $\pm 0.1\text{mm}$
 Angle $\pm 0.5^\circ$
 Unit = mm

| PART NO | CHIP | | Lens Color |
|----------------|---------------------|------------------|-------------|
| | Material | Emitted Color | |
| 12-215UBGC/TR8 | InGaP/SiC Substrate | Super Blue Green | Water Clear |

Office : NO 25,Lane.76,Chung Yang Rd.,Sec.3,

Tucheng, Taipei 236,Taiwan, R.O.C.

TEL : 886-2-2267-2000,2266-9936(22 Lines)

FAX : 886-2-2267-6189

<http://www.everlight.com>



EVERLIGHT ELECTRONICS CO., LTD.

MODEL NO: 12-215UBGC/TR8

Device Number : DSE-125-020 REV. 1.0

Chip LEDs with Right Angle Lens

ECN : _____ Page: 2/8

■ Package Dimension :

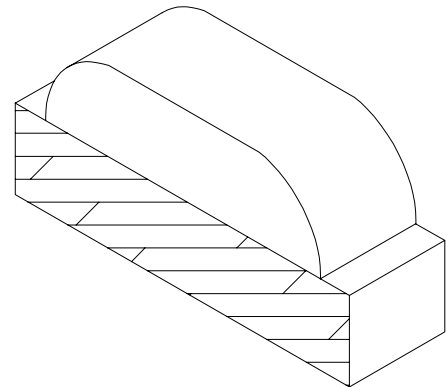
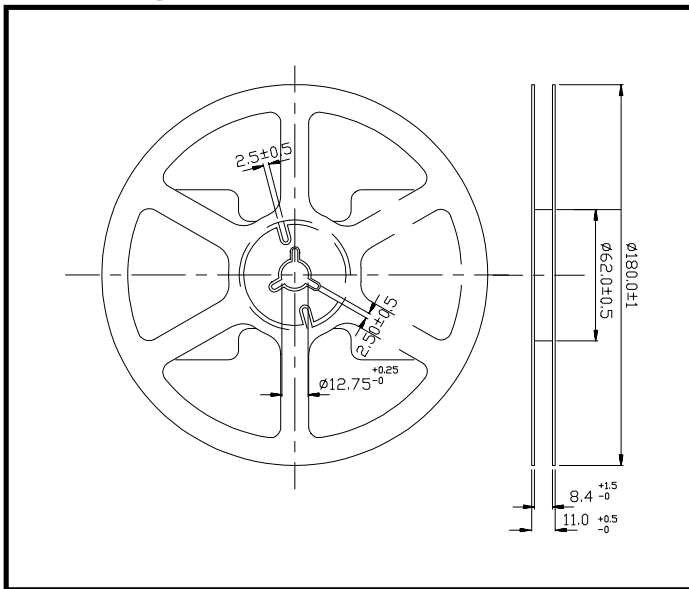

■ Loaded quantity per reel 3000 pcs/reel :

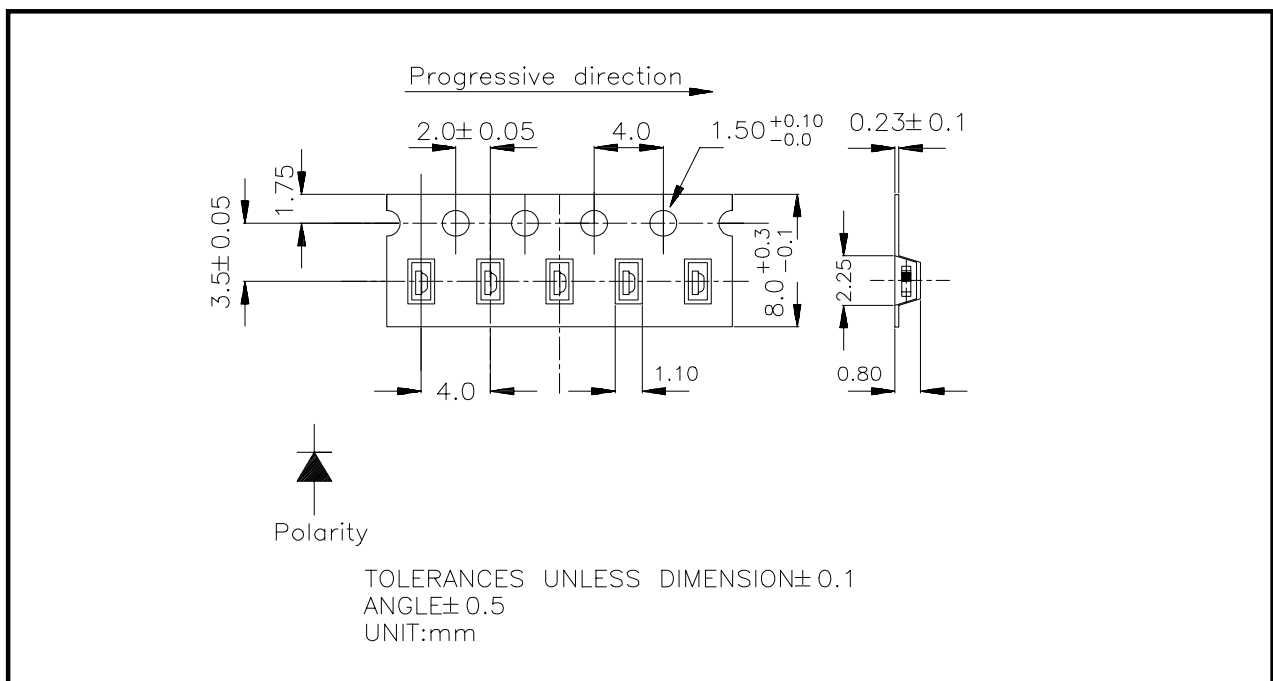



MODEL NO: 12-215UBGC/TR8

Device Number : DSE-125-020 REV. 1.0

Chip LEDs with Right Angle Lens

ECN : _____ Page: 3/8

■ Absolute Maximum Ratings at Ta = 25°C

| Parameter | Symbol | Rating | Unit |
|--|----------|--------------------|------|
| Reverse Voltage | Vr | 5 | V |
| Forward Current | If | 25 | mA |
| Operating Temperature | Topr | -20 ~ +80 | °C |
| Storage Temperature | Tstg | -30 ~ +100 | °C |
| Soldering Temperature | Tsol | 260 (for 5 second) | °C |
| Electrostatic Discharge | ESD | 1000 | V |
| Power Dissipation | Pd | 120 | mW |
| Peak Forward Current(Duty 1/10 @ 1KHZ) | If(Peak) | 100 | mA |

■ Electronic Optical Characteristics :

| Parameter | Symbol | Min. | Typ. | Max. | Unit | Condition |
|------------------------------|--------|-------|-------|-------|------|-----------|
| Luminous intensity | Iv | ----- | 4 | ----- | mcd | If=2mA |
| | | 30 | 70 | ----- | mcd | If=20mA |
| Viewing Angle | 2θ 1/2 | ----- | 130 | ----- | deg | If=20mA |
| Peak Wavelength | λp | ----- | 502 | ----- | nm | If=20mA |
| Dominant Wavelength | λd | ----- | 505 | ----- | nm | If=20mA |
| Spectrum Radiation Bandwidth | Δλ | ----- | 30 | ----- | nm | If=20mA |
| Forward Voltage | Vf | ----- | 3.5 | 4.0 | V | If=20mA |
| Reverse Current | Ir | ----- | ----- | 50 | μA | Vr=5V |



EVERLIGHT ELECTRONICS CO., LTD.

MODEL NO: 12-215UBGC/TR8

Device Number : DSE-125-020 REV. 1.0

Chip LEDs with Right Angle Lens

ECN : _____ Page: 4/8

■ Reliability Test Item And Condition

| NO | Item | Test Conditions | Test Hours/Cycle | Sample Size | Ac/Re |
|----|-------------------------------------|---|------------------|-------------|-------|
| 1 | Solder Heat | TEMP : 260°C ± 5 °C | 5 SEC | 76 Pcs | 0/1 |
| 2 | Temperature Cycle | H : +85°C 30min ∩ 5 min L : -55°C 30min | 50 CYCLE | 76 Pcs | 0/1 |
| 3 | Thermal Shock | H : +100°C 5min ∩ 10 sec L : -10°C 5min | 50 CYCLE | 76 Pcs | 0/1 |
| 4 | High Temperature Storage | TEMP : 100°C | 1000 HRS | 76 Pcs | 0/1 |
| 5 | Low Temperature Storage | TEMP : -55°C | 1000 HRS | 76 Pcs | 0/1 |
| 6 | DC Operating Life | If = 20 mA | 1000 HRS | 76 Pcs | 0/1 |
| 7 | High Temperature / High Humidity | 85°C/85% RH | 1000 HRS | 76 Pcs | 0/1 |



MODEL NO: 12-215UBGC/TR8

Device Number : DSE-125-020 REV. 1.0

Chip LEDs with Right Angle Lens

ECN : _____ Page: 5/8

Typical Electro-Optical Characteristic Curves

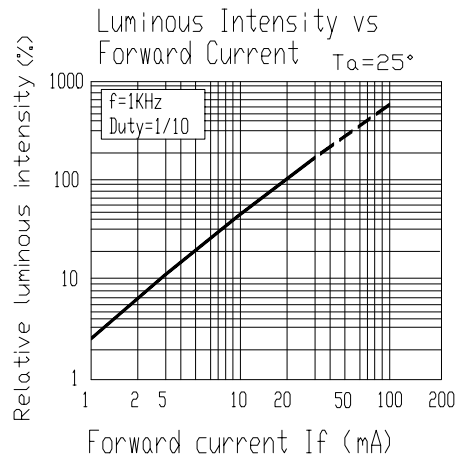
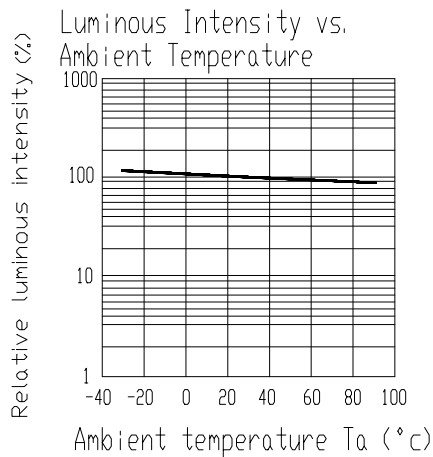
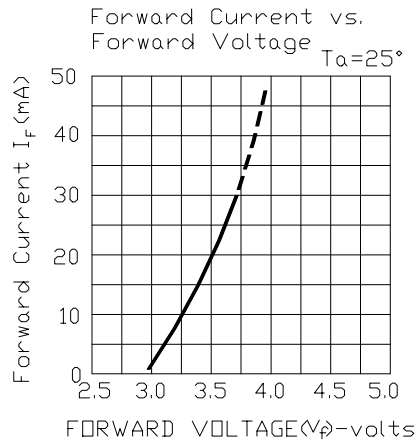
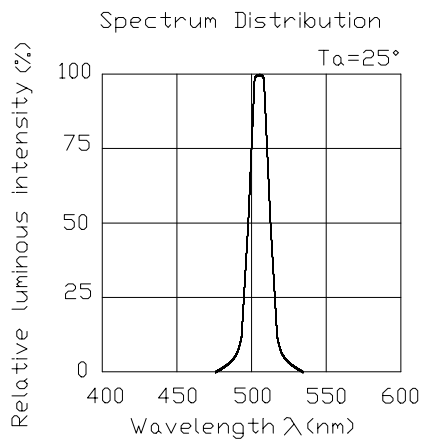

Forward Current Derating Curve

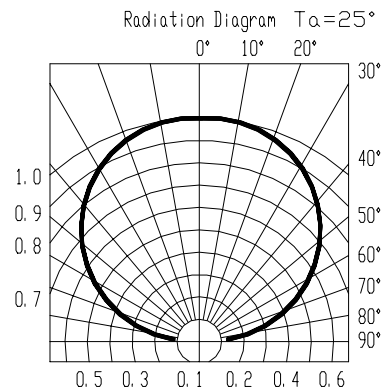
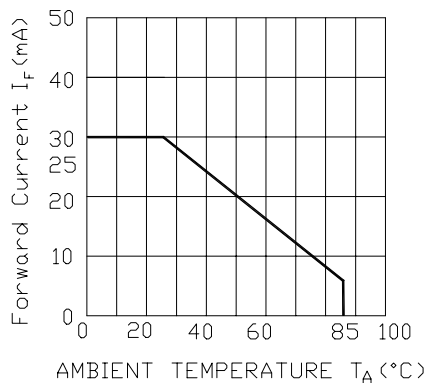



MODEL NO: 12-215UBGC/TR8

Device Number : DSE-125-020 REV. 1.0

Chip LEDs with Right Angle Lens

ECN : Page: 6/8

■ Test Circuit

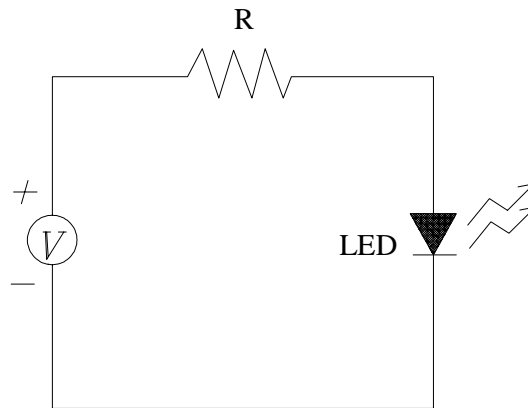

■ Precautions For Use

1. Over-current-proof

Customer must apply resistors for protection , otherwise slight voltage shift will cause big current change (Burn out will happen).

2. Storage time

2.1 The operation of temperature and R.H. are : $5^{\circ}\text{C} \sim 35^{\circ}\text{C}$, R.H.60%.

2.2 Once the package is opened, the products should be used within a week.

Otherwise, they should be keeping in a dampproof box with desiccants.

Considering the tape life , we suggest our customers to use our products within a year(from production date).

2.3 If opened more than one week in an atmosphere $5^{\circ}\text{C} \sim 35^{\circ}\text{C}$, R.H.60%, they should be treated at $60^{\circ}\text{C} \pm 5^{\circ}\text{C}$ for 15hrs.

2.4 When you discover that the desiccant in the package has a pink color (normal = blue) , you should treat them in the same conditions as 2.3.

MODEL NO: 12-215UBGC/TR8

Device Number : DSE-125-020 REV. 1.0

Chip LEDs with Right Angle Lens

ECN : Page: 7/8

■ **Soldering heat reliability (DIP)**

Please refer to the following figure :

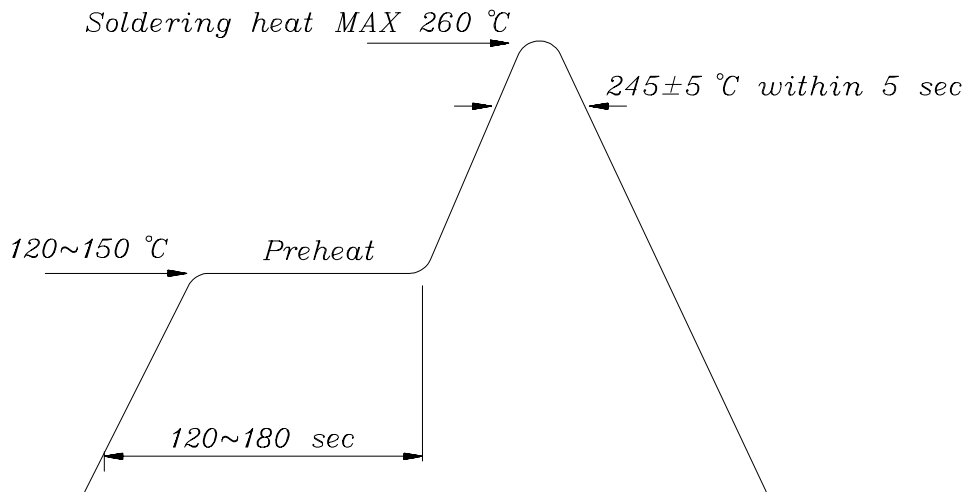

■ **Soldering Iron**

Basic spec is ≤ 5 sec when 260°C . If temperature is higher, time should be shorter ($+10^{\circ}\text{C} \rightarrow -1\text{sec}$). Power dissipation of iron should be smaller than 15 W , and temperature should be controllable. Surface temperature of the device should be under 230°C .

■ **Rework**

1. Customer must finish rework within 5 sec under 260°C .
2. The head of iron can not touch copper foil.
3. Twin-head type is preferred.

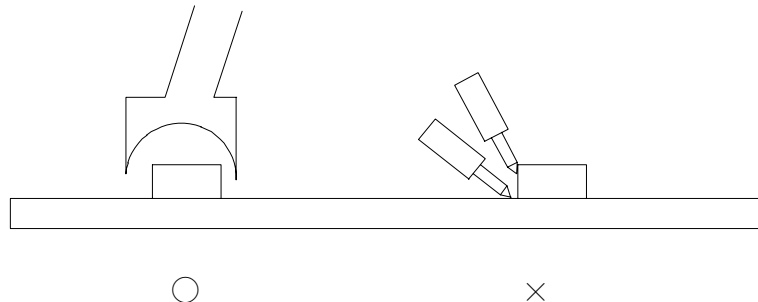



MODEL NO: 12-215UBGC/TR8

Device Number : DSE-125-020 REV. 1.0

Chip LEDs with Right Angle Lens

ECN : Page: 8/8

■ Reflow Temp / Time :

