



MODEL NO: 11-21UBC/C430/TR8
1206 Package Chip LEDs with Inner Lens

Device Number : DSE-111-016 REV. 1.2

ECN : _____ Page: 1/8

Features :

- Package in 8mm tape on 7" diameter reel.
- Compatible with automatic placement equipment.
- Compatible with infrared and vapor phase reflow solder process.
- Mono-color type.

Descriptions :

- The 11-21 SMD Taping is much smaller than lead frame type components, thus enable smaller board size, higher packing density, reduced storage space and finally smaller equipment to be obtained.
- Besides, lightweight makes them ideal for miniature applications, etc.

Applications :

- Automotive: backlighting in dashboard and switch.
- Telecommunication: indicator and backlighting in telephone and fax.
- Flat backlight for LCD, switch and symbol.
- General use.

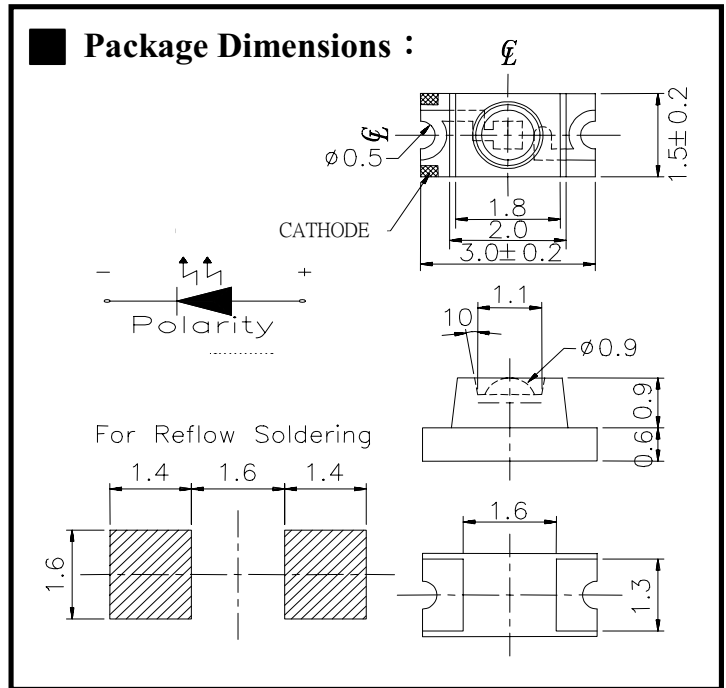

Notes :

Tolerances Unless Dimension $\pm 0.1\text{mm}$
 Angle $\pm 0.5^\circ$
 Unit = mm

PART NO	Chip		Lens Color
	Material	Emitted Color	
11-21UBC/C430/TR8(HT)	GaN/SiC	Super Blue	Water Clear

Office: NO. 25, Lane 76, Sec.3, Chung Yang Rd., Tucheng 236, Taipei, Taiwan, R.O.C.

TEL: 886-2-2267-2000, 2267-9936

FAX: 886-2-2267-6244, 2267-6189, 2267-6306

http: //www.everlight.com



MODEL NO: 11-21UBC/C430/TR8
1206 Package Chip LEDs with Inner Lens

Device Number : DSE-111-016 REV. 1.2

ECN : _____ Page: 2/8

■ **Package Dimensions :**

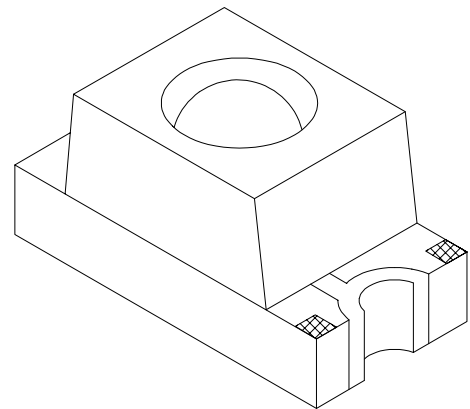
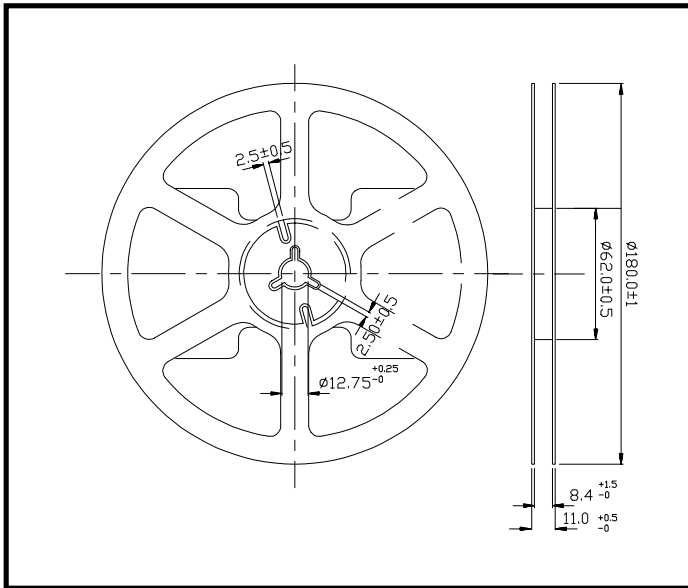

■ **Loaded quantity per reel 2000 pcs/reel :**

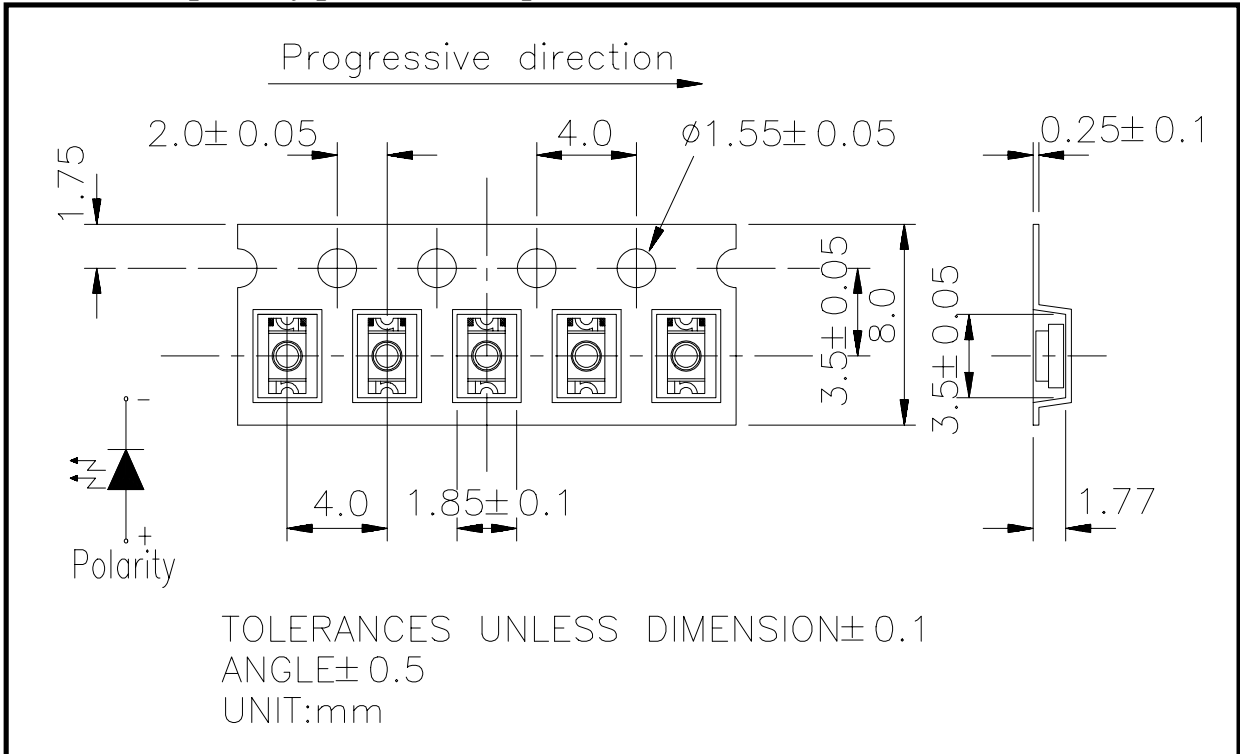



MODEL NO: 11-21UBC/C430/TR8
1206 Package Chip LEDs with Inner Lens

Device Number : DSE-111-016 REV. 1.2

ECN : _____ Page: 3/8

■ **Absolute Maximum Ratings at Ta = 25°C**

Parameter	Symbol	Rating	Unit
Reverse Voltage	Vr	5	V
Forward Current	If	30	mA
Operating Temperature	Topr	-20 ~ +80	°C
Storage Temperature	Tstg	-30 ~ +90	°C
Soldering Temperature	Tsol	260 (for 5 second)	°C
Electrostatic Discharge	ESD	1000	V
Power Dissipation	Pd	140	mW
Peak Forward Current(Duty 1/10 @ 1KHZ)	If(Peak)	70	mA

■ **Electronic Optical Characteristics :**

Parameter	Symbol	Min.	Typ.	Max.	Unit	Condition
Luminous Intensity	Iv	26	33	-----	mcd	If=20mA
Viewing Angle	2θ 1/2	-----	20	-----	deg	If=20mA
Peak Wavelength	λ p	-----	428	-----	nm	If=20mA
Dominant Wavelength	λ d	-----	466	-----	nm	If=20mA
Spectrum Radiation Bandwidth	△λ	-----	65	-----	nm	If=20mA
Forward Voltage	Vf	-----	3.8	4.5	V	If=20mA
Reverse Current	Ir	-----	-----	50	μA	Vr=5V



MODEL NO: 11-21UBC/C430/TR8
1206 Package Chip LEDs with Inner Lens

Device Number : DSE-111-016 REV. 1.2

ECN : _____ Page: 4/8

■ **Reliability Test Items And Conditions:**

NO	Item	Test Conditions	Test Hours/Cycle	Sample Size	Ac/Re
1	Solder Heat	TEMP : 260°C ± 5 °C	5 SEC	76 PCS	0/1
2	Temperature Cycle	H : +85°C 30min ∫ 5 min L : -55°C 30min	50 CYCLE	76 PCS	0/1
3	Thermal Shock	H : +100°C 5min ∫ 10 sec L : -10°C 5min	50 CYCLE	76 PCS	0/1
4	High Temperature Storage	TEMP : 100°C	1000 HRS	76 PCS	0/1
5	Low Temperature Storage	TEMP : -55°C	1000 HRS	76 PCS	0/1
6	DC Operating Life	If = 20 mA	1000 HRS	76 PCS	0/1
7	High Temperature / High Humidity	85°C/85% RH	1000 HRS	76 PCS	0/1



MODEL NO: 11-21UBC/C430/TR8
1206 Package Chip LEDs with Inner Lens

Device Number : DSE-111-016 REV. 1.2

ECN : _____ Page: 5/8

Typical Electro-Optical Characteristic Curves

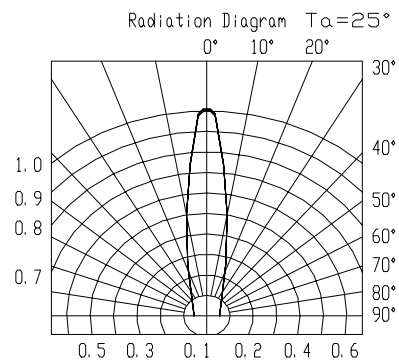
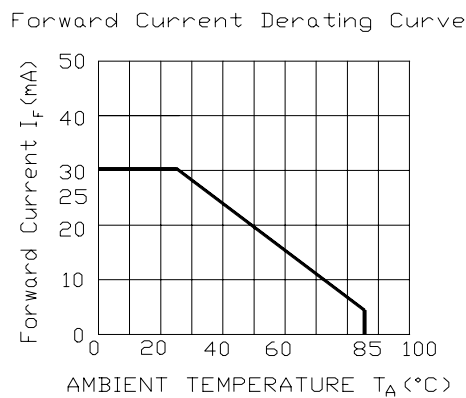
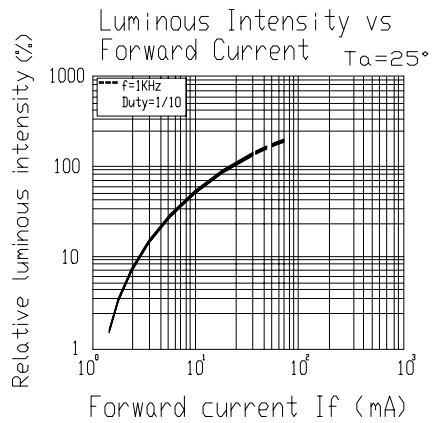
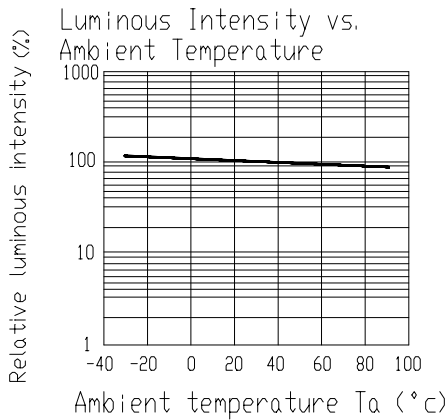
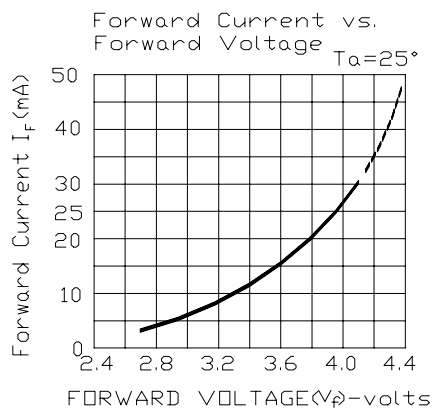
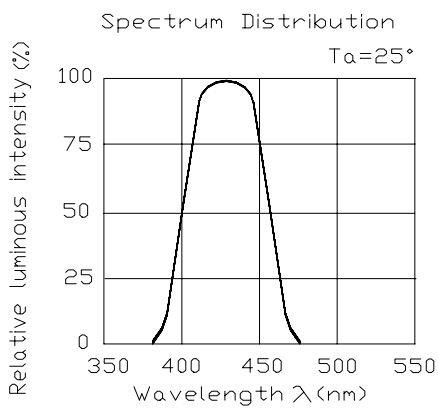



MODEL NO: 11-21UBC/C430/TR8
1206 Package Chip LEDs with Inner Lens

Device Number : DSE-111-016 REV. 1.2

ECN : _____ Page: 6/8

■ Test Circuit

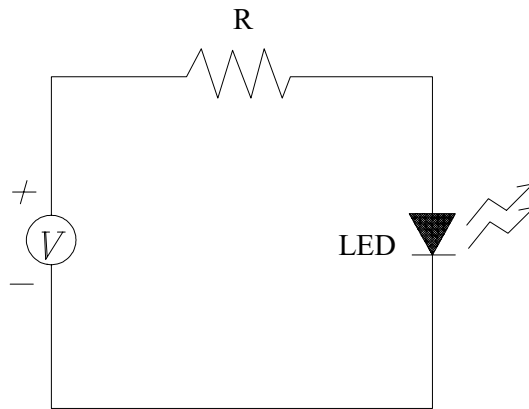

■ Precautions For Use

1. Over-current-proof

Customer must apply resistors for protection , otherwise slight voltage shift will cause big current change (Burn out will happen).

2. Storage time

2.1 The operation of temperature and R.H. are : $5^{\circ}\text{C}\sim 35^{\circ}\text{C}$, R.H.60%.

2.2 Once the package is opened, the products should be used within a week.

Otherwise, they should be keeping in a damp proof box with desiccating agent.
Considering the tape life , we suggest our customers to use our products within a year(from production date).

2.3 If opened more than one week in an atmosphere $5^{\circ}\text{C}\sim 35^{\circ}\text{C}$, R.H.60%, they should be treated at $60^{\circ}\text{C} \pm 5^{\circ}\text{C}$ for 15hrs.

2.4 When you discover that the desiccant in the package has a pink color (Normal = blue) , you should treat them in the same conditions as 2.3.



MODEL NO: 11-21UBC/C430/TR8
1206 Package Chip LEDs with Inner Lens

Device Number : DSE-111-016 REV. 1.2

ECN : _____ Page: 7/8

■ **Soldering heat reliability (DIP)**

Please refer to the following figure :

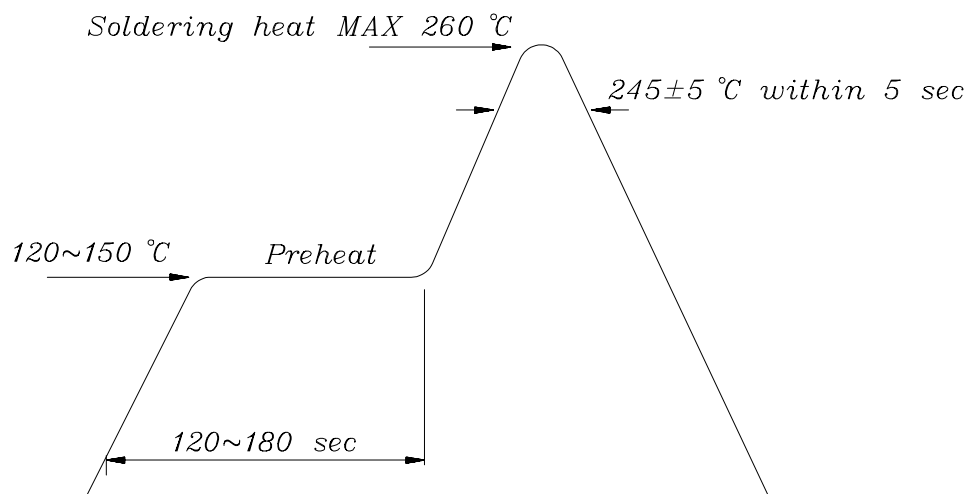

■ **Soldering Iron**

Basic spec is ≤ 5 sec when 260°C. If temperature is higher, time should be shorter (+10°C → -1sec). Power dissipation of iron should be smaller than 15 W , and temperature should be controllable. Surface temperature of the device should be under 230 °C .

■ **Rework**

1. Customer must finish rework within 5 sec under 260°C .
2. The head of iron can not touch copper foil.
3. Twin-head type is preferred.

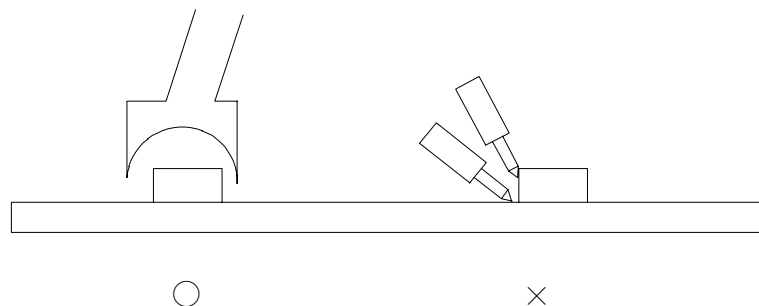



MODEL NO: 11-21UBC/C430/TR8

Device Number : DSE-111-016 REV. 1.2

1206 Package Chip LEDs with Inner Lens

ECN : _____ Page: 8/8

■ Reflow Temp / Time :

