

1.5MHz, 800mA Synchronous Step-Down Converter with Soft Start

DESCRIPTION

The EUP3408 is a constant frequency, current mode, PWM step-down converter. The device integrates a main switch and a synchronous rectifier for high efficiency. The 2.5V to 5.5V input voltage range makes the EUP3408 ideal for powering portable equipment that runs from a single cell Lithium-Ion (Li+) battery or 3-cell NiMH/ NiCd batteries. The output voltage can be regulated as low as 0.6V. The EUP3408 supports up to 800mA load current and can also run at 100% duty cycle for low dropout applications, extending battery life in portable systems.

Switching frequency is internally set at 1.5MHz, allowing the use of small surface mount inductors and capacitors. The internal synchronous switch increases efficiency while eliminates the need for an external Schottky diode. The EUP3408 is available in an adjustable version and fixed output voltage of 1.2V, 1.8V and 3.3V.

FEATURES

- High Efficiency up to 96%
- 1.5MHz Constant Switching Frequency
- 800mA Available Load Current
- 270 μ A Typical Quiescent Current
- 2.5V to 5.5V Input Voltage Range
- Adjustable Output Voltage as Low as 0.6V
- 100% Duty Cycle Low Dropout Operation
- No Schottky Diode Required
- Short Circuit and Thermal Protection
- Excellent Line and Load Transient Response
- < 1 μ A Shutdown Current
- Soft Start Function
- Over Voltage Protection
- Available in 1.2V, 1.8V, 3.3V and adjustable voltages
- Available in SOT23-5, TSOT23-5 Package
- RoHS Compliant and 100% Lead(Pb)-Free

APPLICATIONS

- Cellular and Smart Phones
- Portable Media Players/ MP3 Players
- Digital Still and Video Cameras
- Portable Instruments
- WLAN PC Cards

Typical Application Circuit

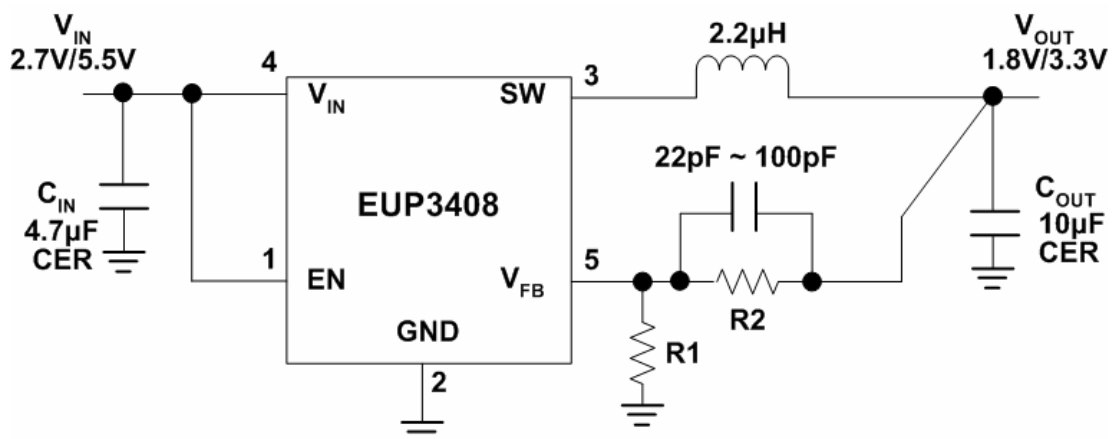

Figure 1. Adjustable Output

Typical Application Circuit (continued)

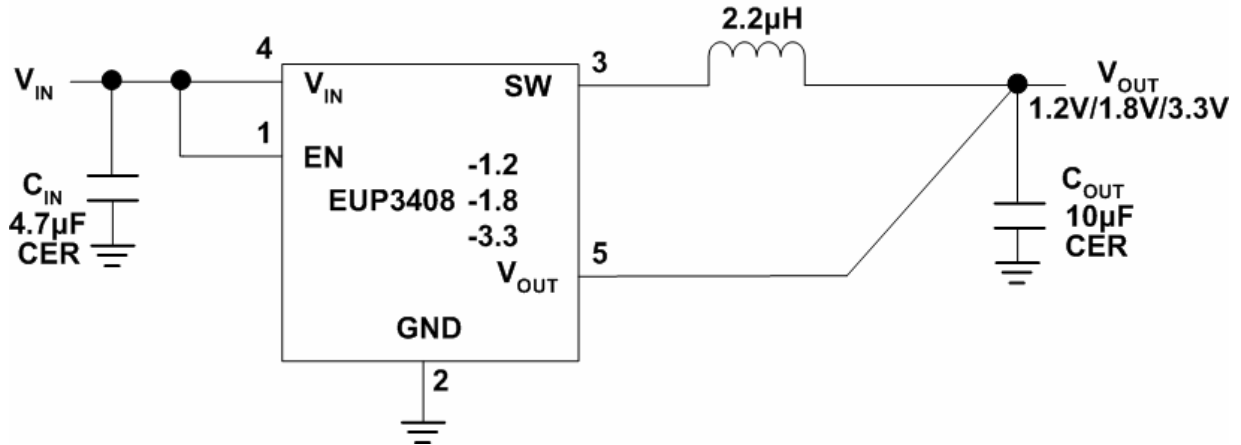

Figure 2. Fixed 1.2V/1.8V/3.3V Output

Pin Configurations

Package Type	Pin Configurations	Package Type	Pin Configurations
SOT23-5 TSOT23-5 ADJ Voltage		SOT23-5 TSOT23-5 Fixed Voltage	

Pin Description

PIN	Pin	DESCRIPTION
EN	1	Chip Enable Pin. Forcing this pin above 1.5V enables the part. Forcing this pin below 0.3V shuts down the device. Do not leave EN floating.
GND	2	Common Ground.
SW	3	Switch Node Connection to Inductor. This pin connects to the drains of the internal main and synchronous power MOSFET switches.
V _{IN}	4	Supply Voltage Pin.
V _{FB}	5	Feedback Pin (EUP3408).
V _{OUT}	5	Output Voltage Feedback Pin (EUP3408-1.2/1.8/3.3)

Block Diagram

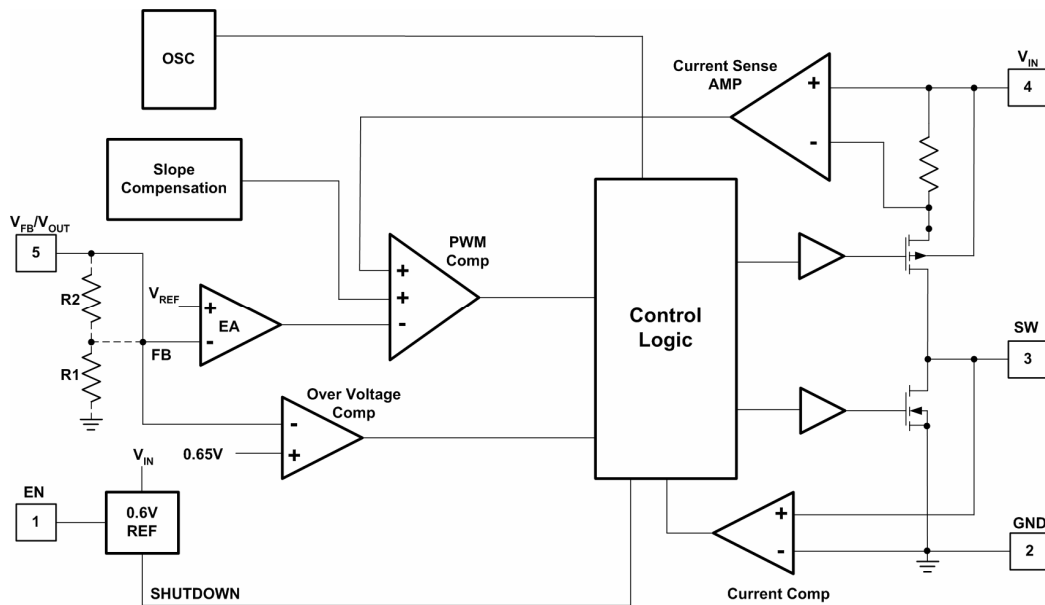

Ordering Information

Order Number	Package Type	Marking	Operating Temperature range
EUP3408VIR1	SOT23-5	a A □ □ □	-40 °C to 85°C
EUP3408-1.2VIR1	SOT23-5	a T □ □ □	-40 °C to 85°C
EUP3408-1.8VIR1	SOT23-5	a D □ □ □	-40 °C to 85°C
EUP3408-3.3VIR1	SOT23-5	a H □ □ □	-40 °C to 85°C
EUP3408OIR1	TSOT23-5	a A □ □ □	-40 °C to 85°C
EUP3408-1.2OIR1	TSOT23-5	a T □ □ □	-40 °C to 85°C
EUP3408-1.8OIR1	TSOT23-5	a D □ □ □	-40 °C to 85°C
EUP3408-3.3OIR1	TSOT23-5	a H □ □ □	-40 °C to 85°C

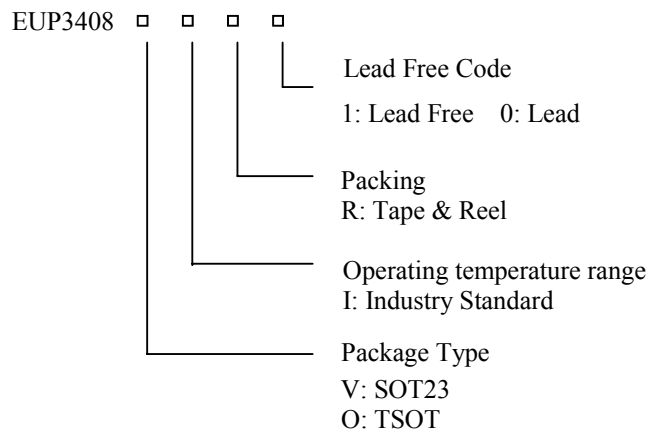

Absolute Maximum Ratings

- Input Supply Voltage ----- -0.3V to 6V
- EN, V_{FB} Voltages ----- -0.3V to V_{IN}
- P-Channel Switch Source Current (DC) ----- 1A
- N-Channel Switch Sink Current (DC) ----- 1A
- Peak SW Sink and Source Current ----- 1.6A
- Operating Temperature Range ----- -40°C to 85°C
- Junction Temperature ----- 125°C
- Storage Temperature ----- -65°C to 150°C
- Lead Temp (Soldering, 10sec) ----- 260°C

Electrical Characteristics

Unless otherwise specified, T_A=25°C, V_{IN}=3.6V.

Symbol	Parameter	Conditions	EUP3408			Unit
			Min	Typ	Max.	
V _{IN}	Input Voltage Range		2.5		5.5	V
I _{VFB}	Feedback Current			±30		nA
I _Q	Quiescent Current	V _{FB} =0.5V or V _{OUT} =90%, SW Open		270	370	μA
I _{SHDN}	Shutdown Current	V _{EN} =0V, V _{IN} = 4.2V			1	μA
I _{PK}	Peak Inductor Current	V _{IN} =3V, V _{FB} =0.5V or V _{OUT} =90%	1.05	1.25		A
V _{FB}	Regulated Feedback Voltage	(Note 1)	0.588	0.6	0.612	V
V _{OUT}	Regulated Output Voltage	I _{LOAD} = 0	-3		3	%
ΔV _{OUT}	Output Voltage Line Regulation	V _{IN} =2.5V to 5.5V, I _{LOAD} =0		0.25	0.4	%/V
ΔV _{FB}	Reference Voltage Line Regulation	V _{IN} =2.5V to 5.5V		0.25	0.4	%/V
V _{LOADREG}	Output Voltage Load Regulation	I _{LOAD} = 0mA to 800mA		0.5		%
f _{OSC}	Oscillator Frequency	V _{FB} =0.6V or V _{OUT} =100%	1.2	1.5	1.8	MHz
		V _{FB} =0V or V _{OUT} =0V		700		kHz
R _{PFET}	R _{DS(ON)} of P-Channel FET	I _{SW} =200mA		0.28	0.4	Ω
R _{NFET}	R _{DS(ON)} of N-Channel FET	I _{SW} =-200mA		0.30	0.4	Ω
I _{LSW}	SW Leakage Current	V _{EN} =0V, V _{SW} =0V or 5V, V _{IN} =5V			±1	μA
V _{EN}	EN Threshold		0.3	1.0	1.5	V
I _{EN}	EN Leakage Current				1	μA

Note 1: The EUP3408 is tested in a proprietary test mode that connects V_{FB} to the output of the error amplifier.

Typical Operating Characteristics

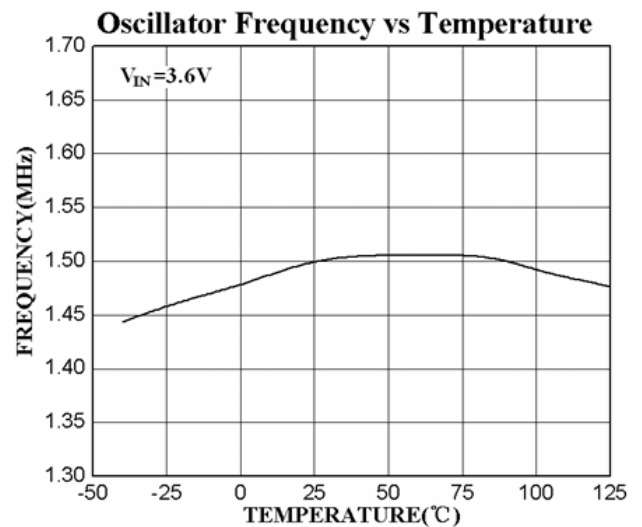
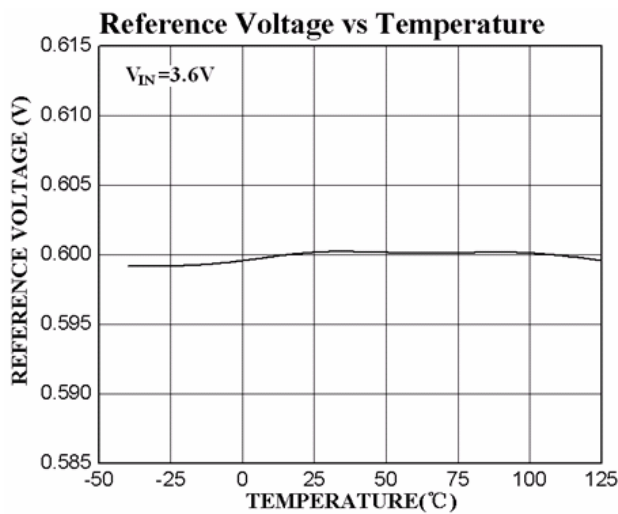
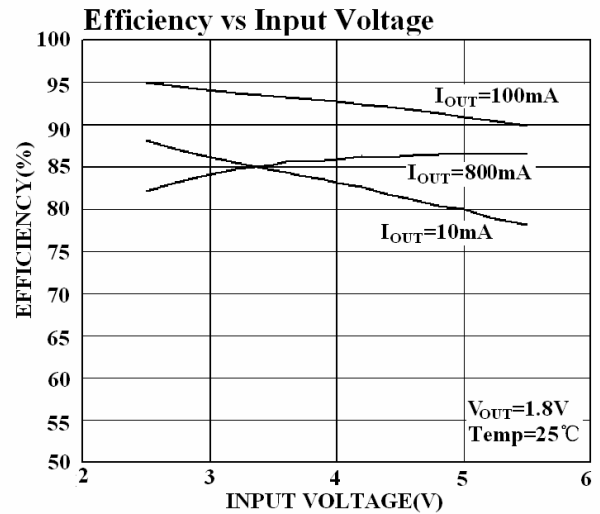
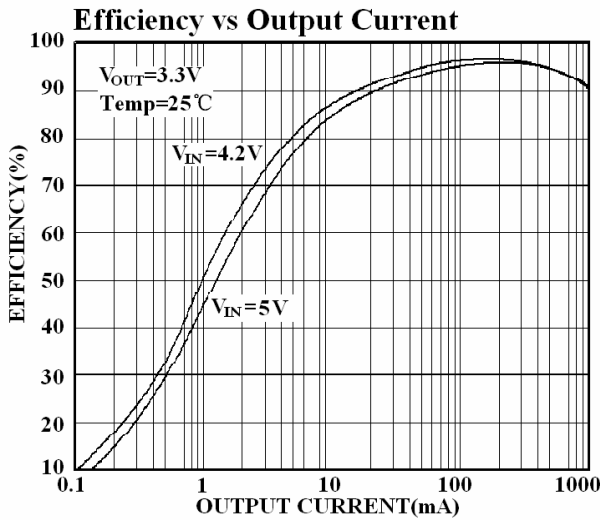
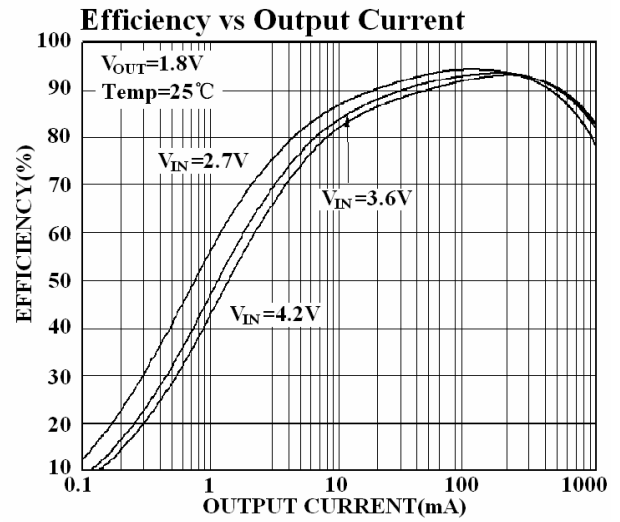
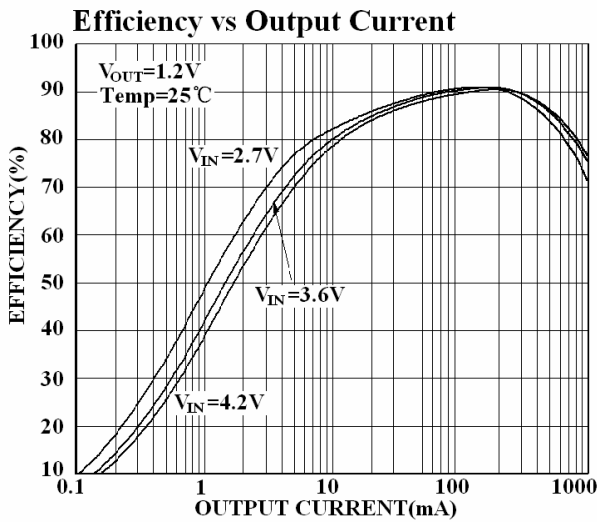

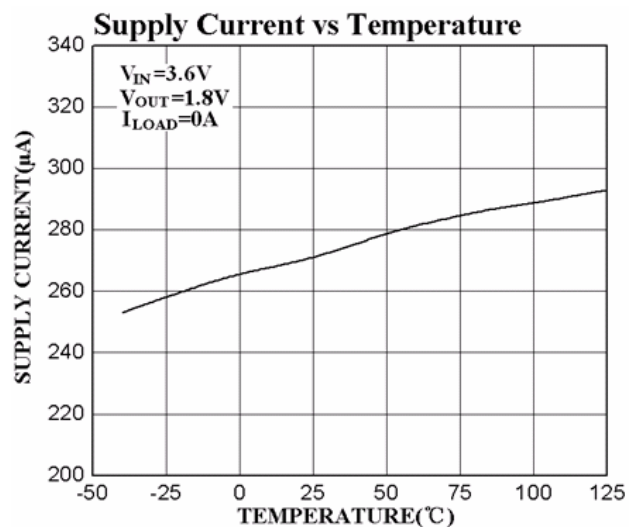
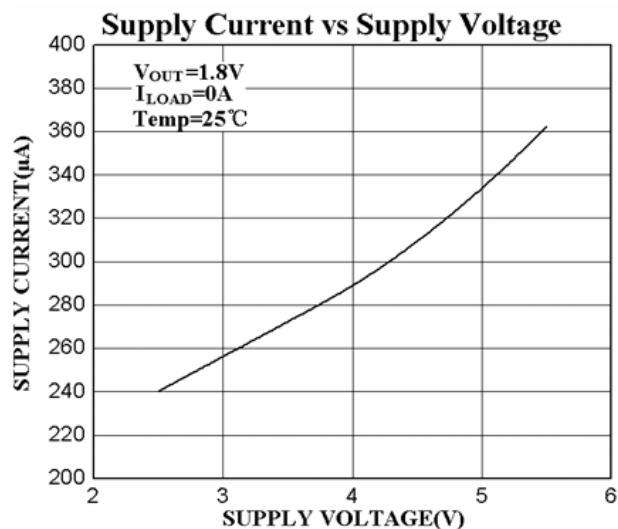
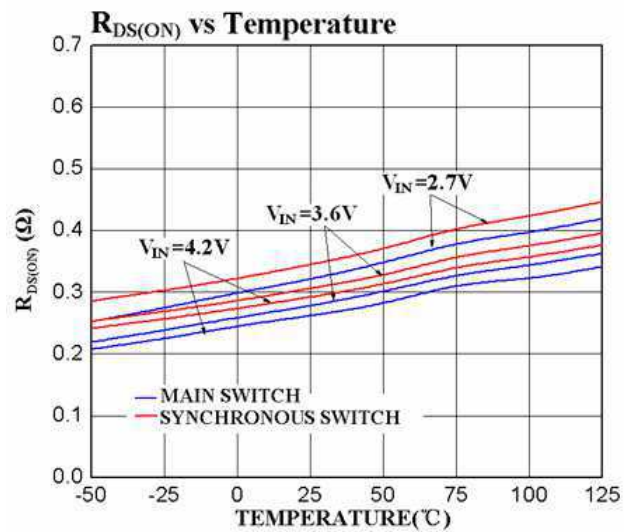
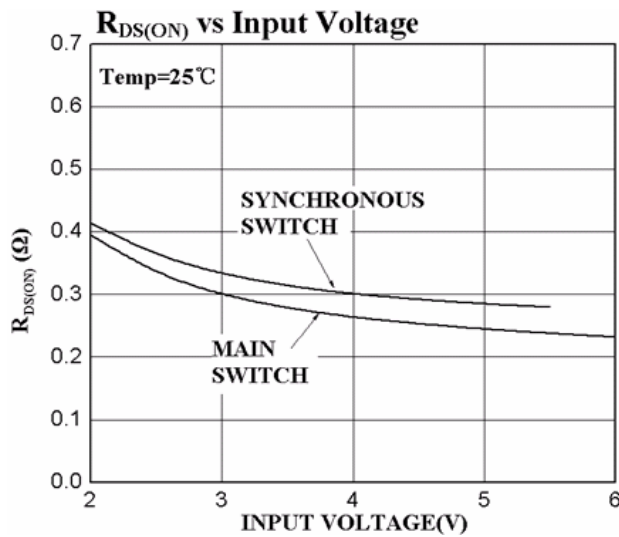
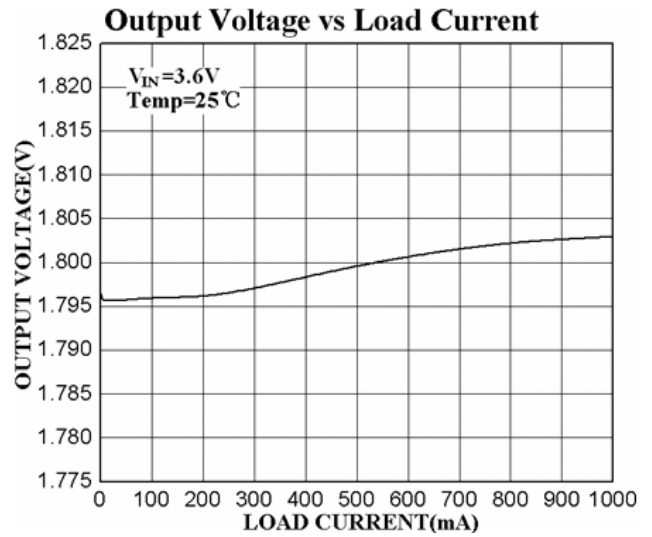
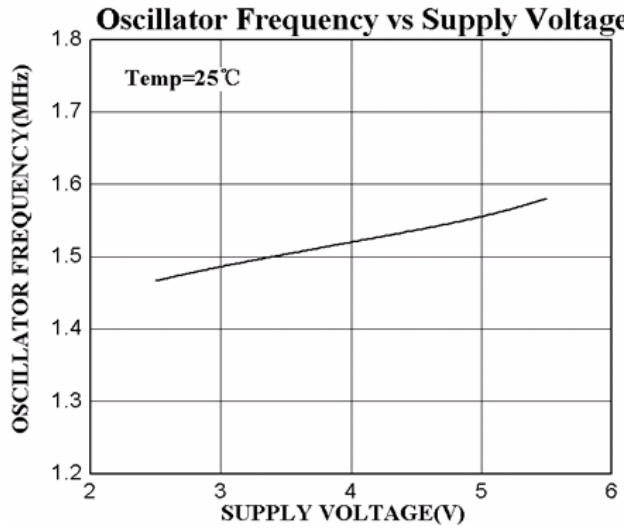

Discontinuous Operation

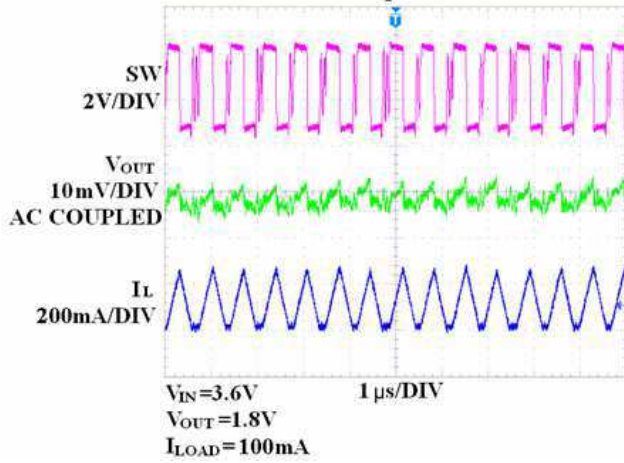

Normal Operation

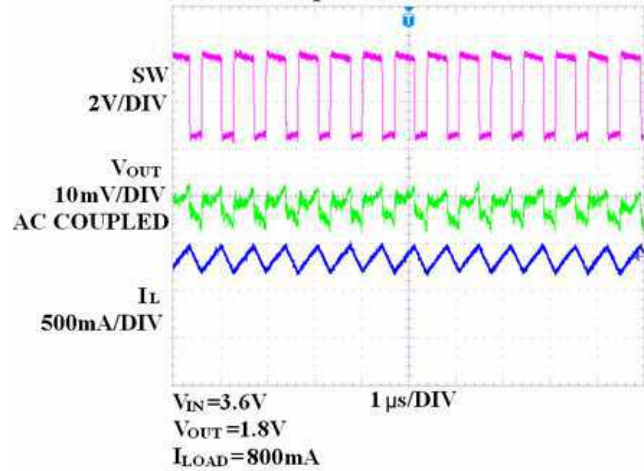

Start-Up from Shutdown

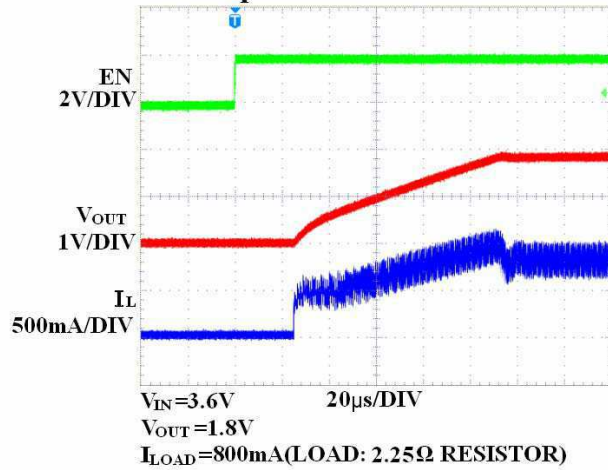

Load Step

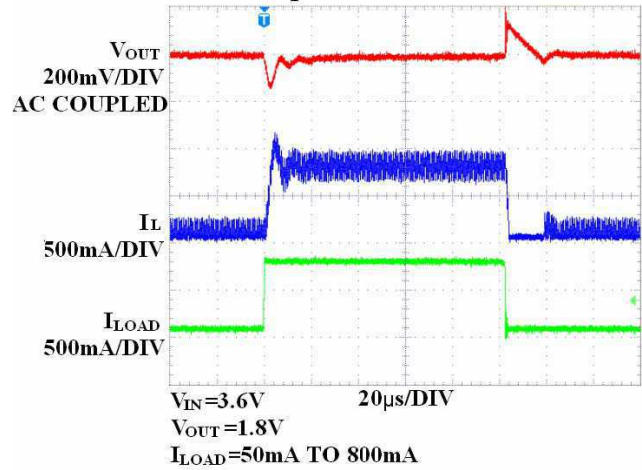

Load Step

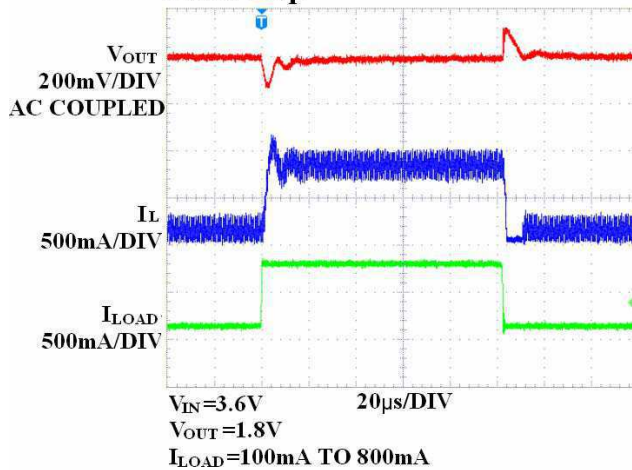

Load Step

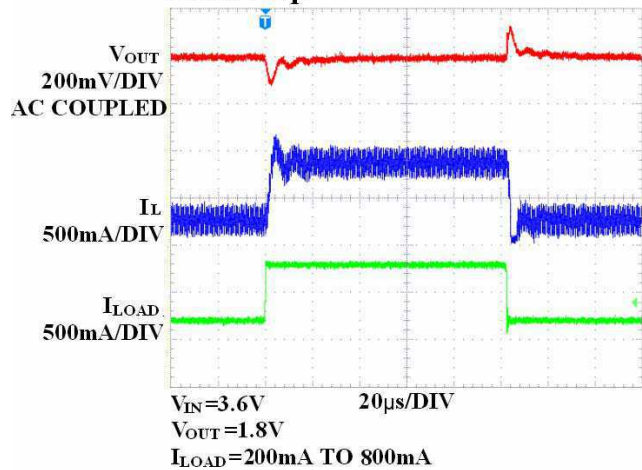

Application Information

Main Control Loop

The EUP3408 uses a slope-compensated constant frequency, current mode architecture. Both the main (P-Channel MOSFET) and synchronous (N-channel MOSFET) switches are internal. During normal operation, the EUP3408 regulates output voltage by switching at a constant frequency and then modulating the power transferred to the load each cycle using PWM comparator. The duty cycle is controlled by three weighted differential signals: the output of error amplifier, the main switch sense voltage and the slope-compensation ramp. It modulates output power by adjusting the inductor-peak current during the first half of each cycle. An N-channel, synchronous switch turns on during the second half of each cycle (off time). When the inductor current starts to reverse or when the PWM reaches the end of the oscillator period, the synchronous switch turns off. This keeps excess current from flowing backward through the inductor, from the output capacitor to GND, or through the main and synchronous switch to GND.

Inductor Selection

The output inductor is selected to limit the ripple current to some predetermined value, typically 20%~40% of the full load current at the maximum input voltage. Large value inductors lower ripple currents. Higher V_{IN} or V_{OUT} also increases the ripple current as shown in equation. A reasonable starting point for setting ripple current is $\Delta I_L=320\text{mA}$ (40% of 800mA).

$$\Delta I_L = \frac{1}{f(L)} V_{OUT} \left(1 - \frac{V_{OUT}}{V_{IN}} \right)$$

The DC current rating of the inductor should be at least equal to the maximum load current plus half the ripple current to prevent core saturation. Thus, a 960mA rated inductor should be enough for most applications (800mA+160mA). For better efficiency, choose a low DC-resistance inductor.

C_{IN} and C_{OUT} Selection

In continuous mode, the source current of the top MOSFET is a square wave of duty cycle V_{OUT}/V_{IN} . The primary function of the input capacitor is to provide a low impedance loop for the edges of pulsed current drawn by the EUP3408. A low ESR input capacitor sized for the maximum RMS current must be used. The size required will vary depending on the load, output voltage and input voltage source impedance characteristics. A typical value is around 4.7 μF .

The input capacitor RMS current varies with the input voltage and the output voltage. The equation for the maximum RMS current in the input capacitor is:

$$I_{RMS} = I_O \times \sqrt{\frac{V_O}{V_{IN}} \times \left(1 - \frac{V_O}{V_{IN}} \right)}$$

The output capacitor C_{OUT} has a strong effect on loop stability.

The selection of C_{OUT} is driven by the required effective series resistance (ESR).

ESR is a direct function of the volume of the capacitor; that is, physically larger capacitors have lower ESR. Once the ESR requirement for C_{OUT} has been met, the RMS current rating generally far exceeds the $I_{RIPPLE(P-P)}$ requirement. The output ripple ΔV_{OUT} is determined by:

$$\Delta V_{OUT} \cong \Delta I_L \left(\text{ESR} + \frac{1}{8fC_{OUT}} \right)$$

When choosing the input and output ceramic capacitors, choose the X5R or X7R dielectric formulations. These dielectrics have the best temperature and voltage characteristics of all the ceramics for a given value and size.

Output Voltage Programming

The output voltage is set by a resistive divider according to the following formula:

$$V_{OUT} = 0.6V \left(1 + \frac{R2}{R1} \right)$$

For adjustable voltage package, the external resistive divider is connected to the output, allowing remote voltage sensing as shown in below figure.

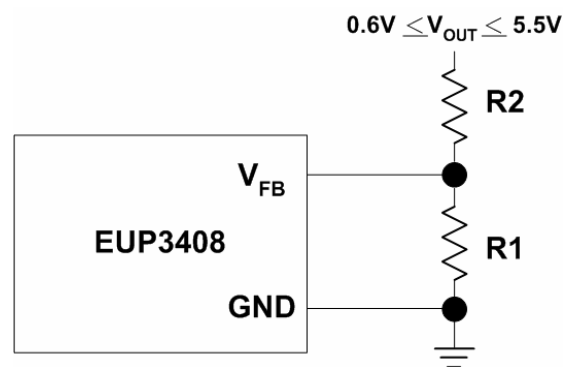

Thermal Considerations

To avoid the EUP3408 from exceeding the maximum junction temperature, the user will need to do a thermal analysis. The goal of the thermal analysis is to determine whether the operating conditions exceed the maximum junction temperature of the part. The temperature rise is given by:

$$T_R = (P_D)(\theta_{JA})$$

Where $P_D = I_{LOAD}^2 \times R_{DS(ON)}$ is the power dissipated by the regulator ; θ_{JA} is the thermal resistance from the junction of the die to the ambient temperature.

The junction temperature, T_J , is given by:

$$T_J = T_A + T_R$$

Where T_A is the ambient temperature.

T_J should be below the maximum junction temperature of 125°C.

PC Board Layout Checklist

When laying out the printed circuit board, the following guidelines should be used to ensure proper operation of the EUP3408.

1. The input capacitor C_{IN} should connect to V_{IN} as closely as possible. This capacitor provides the AC current to the internal power MOSFETs.
2. The power traces, consisting of the GND trace, the SW trace and the V_{IN} trace should be kept short, direct and wide.
3. The V_{FB} pin should connect directly to the feedback resistors. The resistive divider R1/R2 must be connected between the C_{OUT} and ground.
4. Keep the switching node, SW, away from the sensitive V_{FB} node.

Packaging Information

SOT23-5

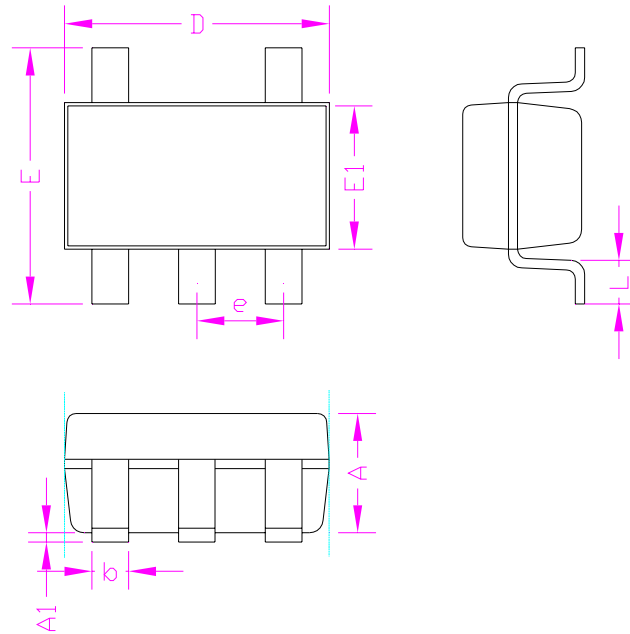

SYMBOLS	MILLIMETERS		INCHES	
	MIN.	MAX.	MIN.	MAX.
A	-	1.30	-	0.052
A1	0.00	0.15	0.000	0.006
D	2.90		0.114	
E1	1.60		0.063	
E	2.60	3.00	0.102	0.118
L	0.30	0.60	0.012	0.024
b	0.30	0.50	0.012	0.020
e	0.95		0.037	

Packaging Information (continued)

TSOT23-5

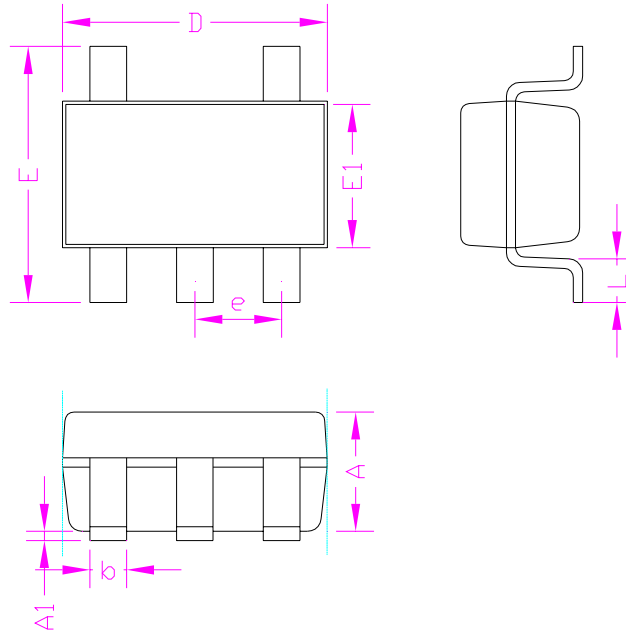

SYMBOLS	MILLIMETERS		INCHES	
	MIN.	MAX.	MIN.	MAX.
A	-	1.00	-	0.039
A1	0.00	0.15	0.000	0.006
D	2.90		0.114	
E1	1.60		0.063	
E	2.60	3.00	0.102	0.118
L	0.30	0.60	0.012	0.024
b	0.30	0.50	0.012	0.020
e	0.95		0.037	