

32V Step-Up Converters for Two to Nine White LEDs

DESCRIPTION

The EUP2595 is a constant current step-up converter specially designed for driving white LEDs. The step-up converter topology allows series connection of the white LEDs so the LED currents are identical for uniform brightness. The EUP2595 can drive 9 LEDs in series. The brightness of the LEDs can be adjusted through a voltage level on the CTRL pin or by applying a PWM signal to CTRL pin.

1MHz current-mode, pulse-width modulated (PWM) operation allows for small input and output capacitors and a small inductor while minimizing ripple on the input supply/battery. Programmable soft-start eliminates inrush current during startup.

The EUP2595 is available in a space-saving, 8-pin 3mm x 3mm TDFN package.

FEATURES

- 2.6V to 5.5V Input Range
- 32V (max) Output with Overvoltage Protection
- Up to 90% Efficiency
- Flexible Analog or PWM Dimming Control
- Internal High Power MOSFET Switch
- < 1μA shutdown Current
- Fast 1MHz PWM Operation
- Small, Low-Profile Inductors and Capacitors
- 3mm × 3mm TDFN-8 Package
- RoHS Compliant and 100% Lead (Pb)-Free

APPLICATIONS

- Cell Phones and Smart Phones
- PDAs, Palmtops, and Wireless Handhelds
- e-Books and Subnotebooks
- White LED Display Backlighting

Typical Application Circuit

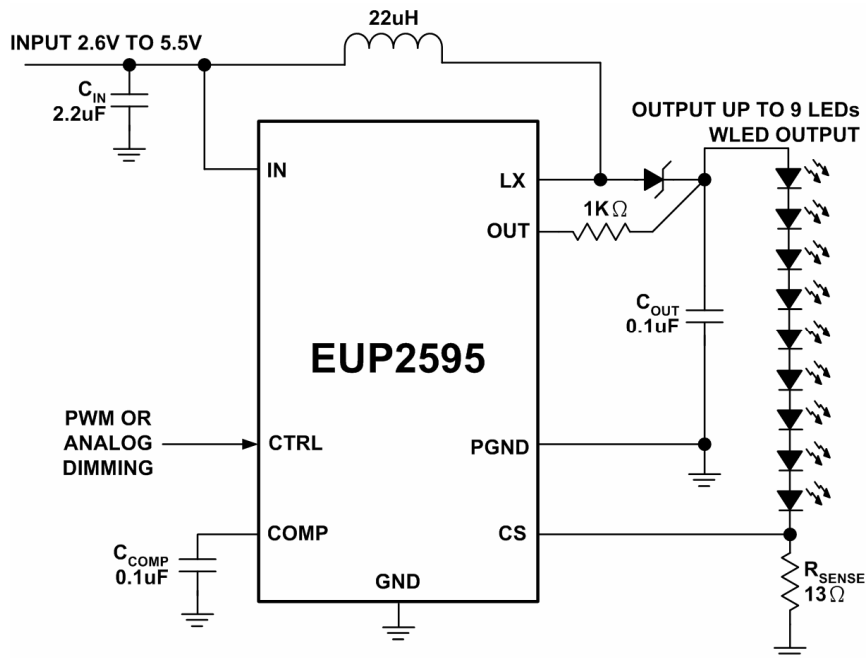
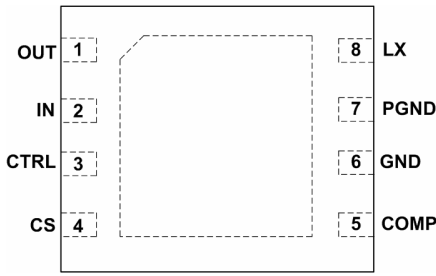

Figure 1. Typical Application Circuit

Pin Configurations

Package Type	Pin Configurations
TDFN-8	 <p>The diagram shows a square package with eight pins. Pin 1 (OUT) is at the top-left, pin 2 (IN) is at the top-middle, pin 3 (CTRL) is at the top-right, and pin 4 (CS) is at the bottom-left. On the right side, pin 8 (LX) is at the top, pin 7 (PGND) is in the middle, pin 6 (GND) is below that, and pin 5 (COMP) is at the bottom-right.</p>

Pin Description

PIN	Pin	DESCRIPTION
OUT	1	WLED output overvoltage sense pin. Add a 1kΩ resistor to improve overvoltage sense accuracy.
IN	2	Input Supply Voltage.
CTRL	3	Brightness Control Input. LED brightness is controlled by the voltage applied to CTRL. Varying the voltage from 0.24V to 1.65V adjusts the brightness from dim to bright, respectively. Any voltage above 1.65V does not increase brightness.
CS	4	Current-Sense Feedback Input. Connect a resistor from CS to GND to set the LED bias current. The voltage at CS regulates to $V_{CTRL} / 5$ or 0.330V, whichever is lower.
COMP	5	Compensation Input. Connect a 0.1μF capacitor (CCOMP) from COMP to GND. CCOMP stabilizes the converter and controls soft-start. CCOMP discharges to GND when in shutdown.
GND	6	Common Ground. Connect to PGND and the exposed pad directly under the IC.
PGND	7	Power Ground. Connect to GND and the exposed pad directly under the IC.
LX	8	Inductor Connection. This pin is high impedance during shutdown.

Absolute Maximum Ratings

- IN to GND ----- -0.3V to 6V
- PGND to GND ----- -0.3V to 0.3V
- LX,OUT to GND ----- -0.3V to 35V
- CTRL to GND ----- -0.3V to the lower of 6V or (V_{IN}+0.5V)
- COMP,CS to GND ----- -0.3V to (V_{IN}+0.3V)
- I_{LX} ----- 1A
- Thermal Resistance
- TDFN-8 ----- 50°C /W
- Junction Temperature ----- 150°C
- Storage Temperature Range ----- -65°C to 150°C
- Lead Temperature (Soldering, 10sec.) ----- 260°C

Recommended Operating Conditions

- Supply Voltage, V_{IN} ----- 2.6V to 5.5V
- Operating Temperature Rang ----- -40°C to 85°C

Electrical Characteristics

(V_{IN} = 3V, L_{in} = 22μH, C_{IN} = 2.2μ, C_{OUT} = 0.1μ, C_{COMP} = 0.1μF, R_{SENSE} = 13Ω, V_{CTRL} = 1.5V, TA = -40°C to +85°C, unless otherwise noted. Typical values are at TA = 25°C.)

Parameter	Conditions	EUP2595			Unit
		Min	Typ	Max.	
Supply Voltage		2.6		5.5	V
UVLO Threshold	V _{IN} Rising	2.23	2.40	2.60	V
	V _{IN} Falling	2.20	2.35	2.55	
UVLO Hysteresis			30		mV
Quiescent Current	No Switching, V _{CTRL} =V _{CS} =1V		350	700	μA
Shutdown Supply Current	V _{OUT1} =V+, EN1=EN2=GND		0.15	1.50	μA
OVLO Threshold	Rising	32	33.5	35	V
	Falling	30	31.3	32.8	
OVLO Hysteresis			2.20		V
OUT Input Bias Current	V _{OUT} =32V, V _{CTRL} > 0.24V		15	25	μA
	V _{OUT} =V _{IN} , CTRL=GND			1	
Output Voltage Range		V _{IN} -V _D		32	V
ERROR AMPLIFIER					
CTRL to CS Regulation	V _{CTRL} = 1.5V, V _{IN} = 2.6V to 5.5V	290	300	310	mV
CS Input Bias Current	V _{CS} = V _{CTRL} /5			1	μA
CTRL Input Resistance	0<V _{CTRL} < 1V	290	530	850	kΩ
CTRL Dual-Mode Threshold		125	190	245	mV
CS Maximum Brightness Clamp Voltage	V _{CTRL} = 3V	310	330	347	mV
COMP Input Resistance to Ground	In Shutdown, UVLO or OVLO	12.8	23.3	35	kΩ

Electrical Characteristics (Continued)

($V_{IN} = 3V$, $L_{in} = 22\mu H$, $C_{IN} = 2.2\mu$, $C_{OUT} = 0.1\mu$, $C_{COMP} = 0.1\mu F$, $R_{SENSE} = 13\Omega$, $V_{CTRL} = 1.5V$,
TA = -40°C to +85°C, unless otherwise noted. Typical values are at **TA = 25°C**.)

Parameter	Conditions	EUP2595			Unit
		Min	Typ	Max.	
CS-to-COMP Transconductance	Vcomp=1V	20	52	85	μS
OSCILLATOR					
Operating Frequency		0.78	1	1.25	MHz
Minimal Duty Cycle	PWM Mode		12		%
	Pulse Skipping		0		
Maximum Duty Cycle	CTRL=IN , CS=GND	93.5	95	97.2	%
N-CHANNEL SWITCH					
LX On-Resistance		0.35	0.86	1.40	Ω
LX Leakage Current	Vlx=32V, CTRL=GND			1	μA
LX Current Limit	Maximum Duty Cycle	550	1150	1720	mA

Typical Operating Characteristics

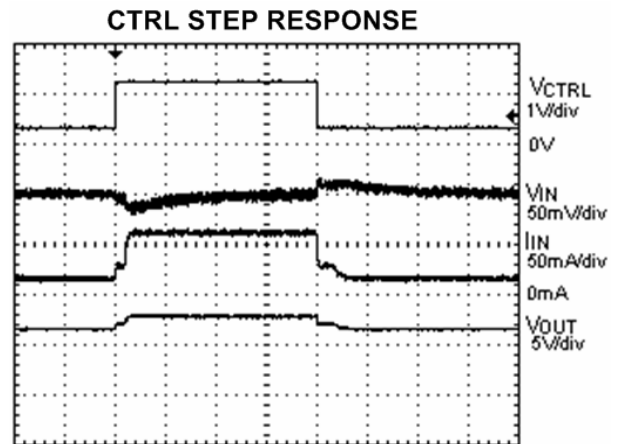
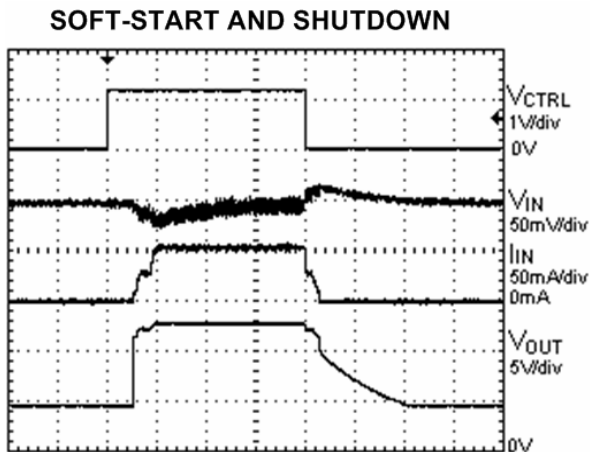
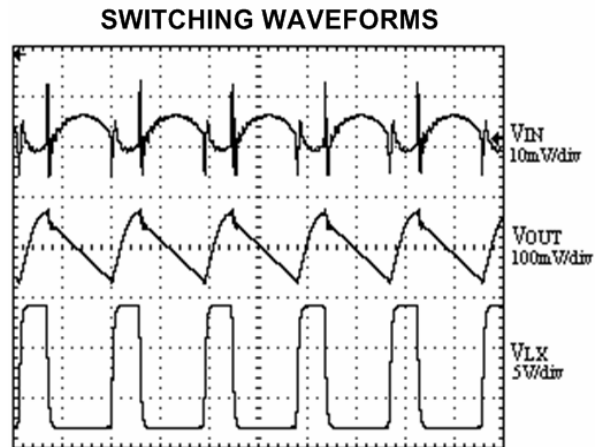
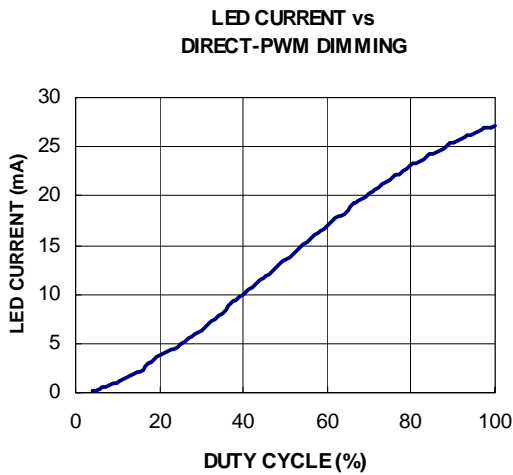
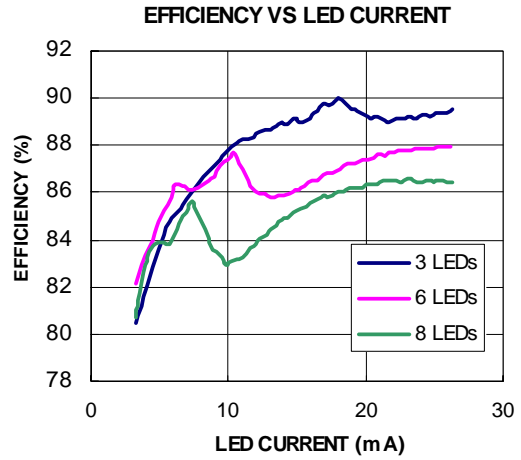
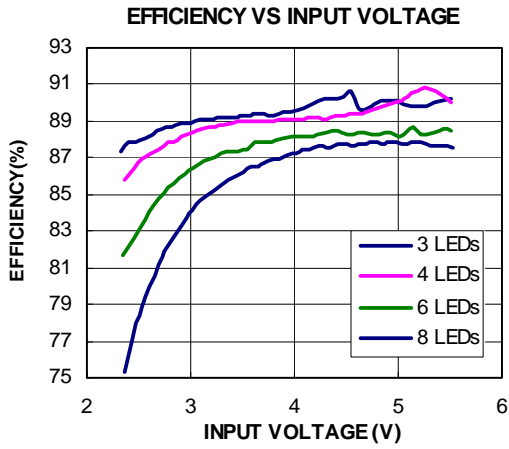

DIRECT-PWM DIMMING

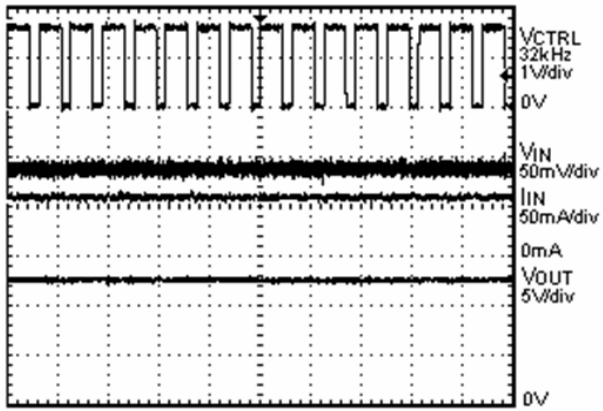

Application Information

Soft-Start

The EUP2595 attain soft-start by charging C_{COMP} gradually with a current source. When V_{COMP} rises above 1.25V, the internal MOSFET begins switching at a reduced duty cycle. When V_{COMP} rises above 2.25V, the duty cycle is at its maximum. See the Typical Operating Characteristics for an example of soft-start operation.

Shutdown

The EUP2595 enter shutdown when V_{CTRL} is less than 100mV for more than 8.2ms. In shutdown, supply current is reduced to 0.3 μ A by powering down the entire IC except for the CTRL voltage-detection circuitry. C_{COMP} is discharged during shutdown, allowing the device to reinitiate soft-start when it is enabled. Although the internal N-channel MOSFET does not switch in shutdown, there is still a DC current path between the input and the LEDs through the inductor and Schottky diode. The minimum forward voltage of the LED array must exceed the maximum input voltage to ensure that the LEDs remain off in shutdown. However, with two or more LEDs, the forward voltage is large enough to keep leakage current low, less than 1 μ A(typ). Typical shutdown timing characteristics are shown in the Typical Operating Characteristics.

Overvoltage Protection

Overvoltage lockout (OVLO) occurs when V_{OUT} is above 32V. The protection circuitry stops the internal MOSFET from switching and causes V_{COMP} to decay to 0V. The device comes out of OVLO and into softstart when V_{OUT} falls below 2.2V.

Adjusting LED Current

Adjusting the EUP2595 output current changes the brightness of the LEDs. An analog input (CTRL) and the sense-resistor value set the output current. Output current is given by:

$$I_{LED} = \frac{V_{CTRL}}{5 \times R_{SENSE}}$$

The V_{CTRL} voltage range for adjusting output current is 0.24V to 1.65V. To set the maximum current, calculate R_{SENSE} when V_{CTRL} is at its maximum as follows:

$$R_{SENSE} = \frac{1.65V}{5 \times I_{LED(MAX)}}$$

Power dissipation in R_{SENSE} is typically less than 10mW, making a standard chip resistor sufficient.

PWM Dimming Control

CTRL is also used as a digital input allowing LED brightness control with a logic-level PWM signal applied directly to CTRL. The frequency range is from 200Hz to 200kHz, while 0% duty cycle corresponds to zero current and 100% duty cycle corresponds to full current. The error amplifier and compensation capacitor form a lowpass filter so PWM dimming results in DC current to the LEDs without the need for any additional RC filters; see the Typical Operating Characteristics.

Capacitor Selection

The exact values of input and output capacitors are not critical. The typical value for the input capacitor is 2.2 μ F and the typical value for the output capacitor is 0.1 μ F. Larger value capacitors can be used to reduce input and output ripple, but at the expense of size and higher cost. C_{COMP} stabilizes the converter and controls soft-start. Connect a 0.1 μ F capacitor from COMP to GND. For stable operation, C_{OUT} must not exceed 10 times C_{COMP} .

Inductor Selection

Inductor values range from 10 μ H to 47 μ H. A 22 μ H inductor optimizes the efficiency for most applications while maintaining low 15mV_{P-P} input ripple. With input voltages near 5V, a larger value of inductance can be more efficient. To prevent core saturation, ensure that the inductor-saturation current rating exceeds the peak inductor current for the application. Calculate the peak inductor current with the following formula:

$$I_{PEAK} = \frac{V_{OUT(MAX)} \times I_{LED(MAX)}}{0.9 \times V_{IN(MIN)}} + \frac{V_{IN(MIN)} \times 0.9\mu s}{2 \times L}$$

Schottky Diode Selection

The EUP2595 high switching frequency demands a high-speed rectification diode (D1) for optimum efficiency. A Schottky diode is recommended due to its fast recovery time and low forward-voltage drop. Ensure that the diode's average and peak current rating exceed the average output current and peak inductor current. In addition, the diode's reverse breakdown voltage must exceed V_{OUT} . The RMS diode current can be calculated from:

$$I_{DIODE(RMS)} \cong \sqrt{I_{OUT} \times I_{PEAK}}$$

PC Board Layout

Due to fast switching waveforms and high-current paths, careful PC board layout is required. An evaluation kit is available to speed design.

When laying out a board, minimize trace lengths between the IC and R_{SENSE} , the inductor, the diode, the input capacitor, and the output capacitor. Keep traces short, direct, and wide. Keep noisy traces, such as the LX node trace, away from CS. The IN bypass capacitor (C_{IN}) should be placed as close to the IC as possible. PGND and GND should be connected directly to the exposed paddle underneath the IC. The ground connections of C_{IN} and C_{OUT} should be as close together as possible. The traces from IN to the inductor and from the Schottky diode to the LEDs may be longer.

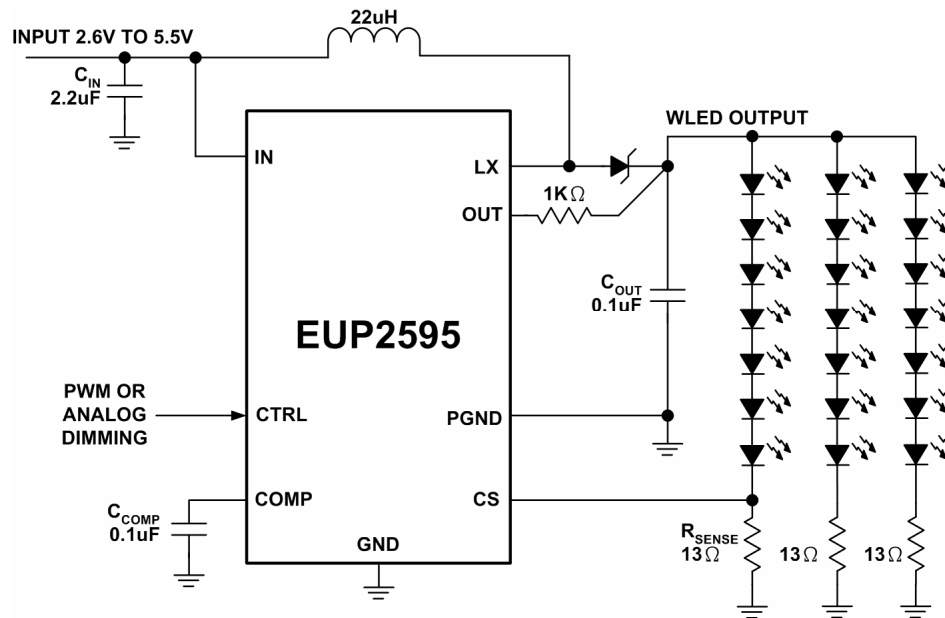
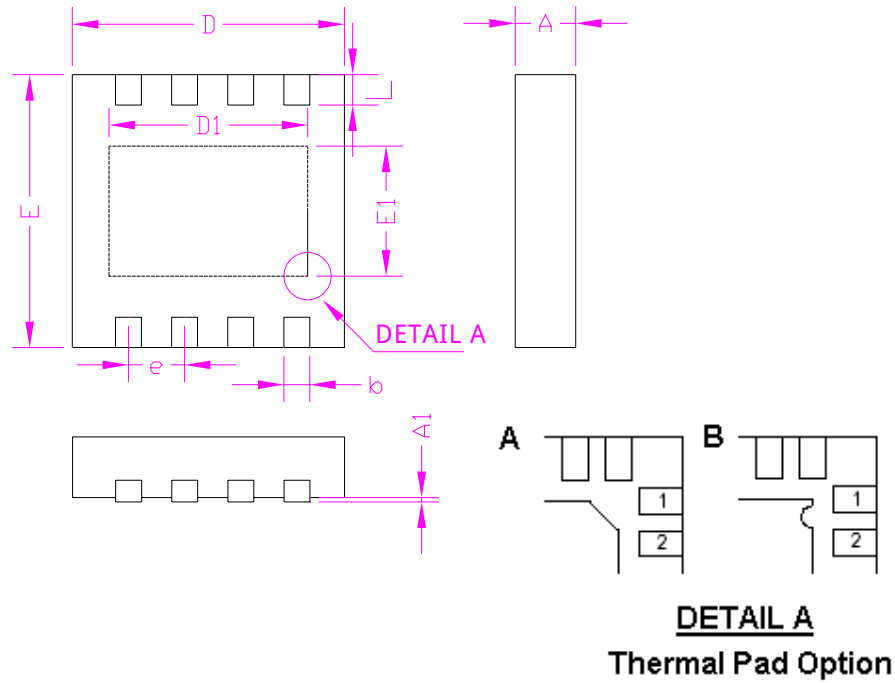

Figure 3. Typical Operating Circuit 21 WLEDs

Packaging Information

TDFN-8



SYMBOLS	MILLIMETERS		INCHES	
	MIN.	MAX.	MIN.	MAX.
A	0.70	0.80	0.028	0.031
A1	0.00	0.05	0.000	0.002
b	0.20	0.40	0.008	0.016
D	2.90	3.10	0.114	0.122
D1	2.30		0.090	
E	2.90	3.10	0.114	0.122
E1	1.50		0.059	
e	0.65		0.026	
L	0.25	0.45	0.010	0.018