

# White LED Driver For Buck-Boost Application

## DESCRIPTION

The EUP2983 is a constant current boost converter specially designed for driving white LEDs with wide input range. The unique converter topology provide a load voltage which can be greater or less than the input voltage. With the tightly regulated load current, the EUP2983 allows series connection with multiple strings of the white LEDs.

The brightness of the LEDs can be adjusted through a voltage level on the CTRL pin or by applying a PWM signal to CTRL pin. 1MHz current-mode, pulse-width modulated (PWM) operation allows for small input and output capacitors and a small inductor while minimizing ripple on the input supply/battery. Programmable soft-start eliminates inrush current during startup.

The EUP2983 is available in a space-saving, 8-pin 3mm x 3mm TDFN package.

## FEATURES

- 6V to 25V Input Range
- 32V (typ.) Output with Overvoltage Protection
- Up to 90% Efficiency
- Flexible Analog or PWM Dimming Control
- Internal High Power MOSFET Switch
- 1MHz PWM Operation
- Small, Low-Profile Inductors and Capacitors
- 3mm× 3mm TDFN-8 Package
- RoHS Compliant and 100% Lead (Pb)-Free

## APPLICATIONS

- 7~10 inch White LED Display Backlighting
- 12V Automotive Display System
- PDVD and Subnotebooks
- LED Lighting

## Typical Application Circuit

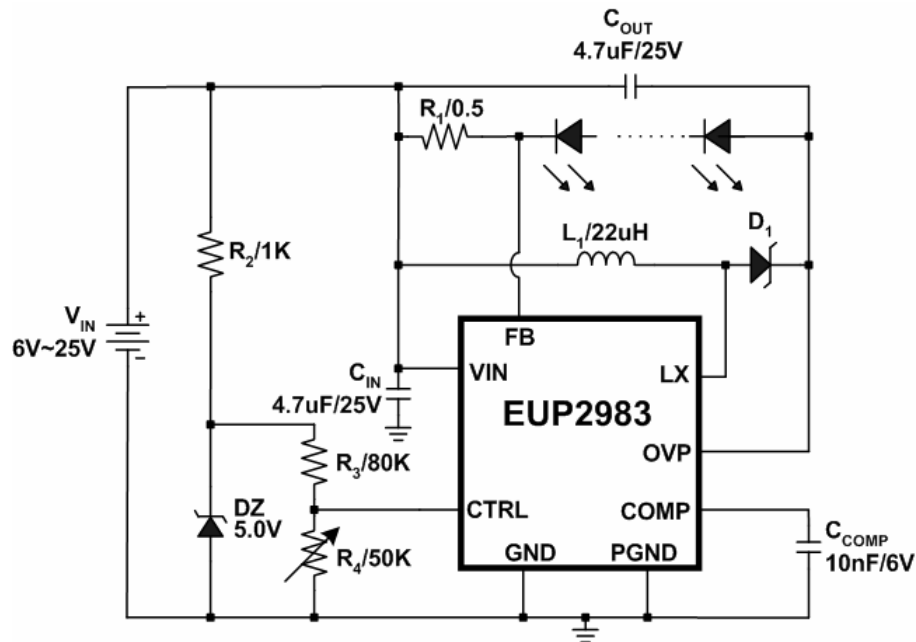

Figure 1. High Brightness LEDs Application

Typical Application Circuit

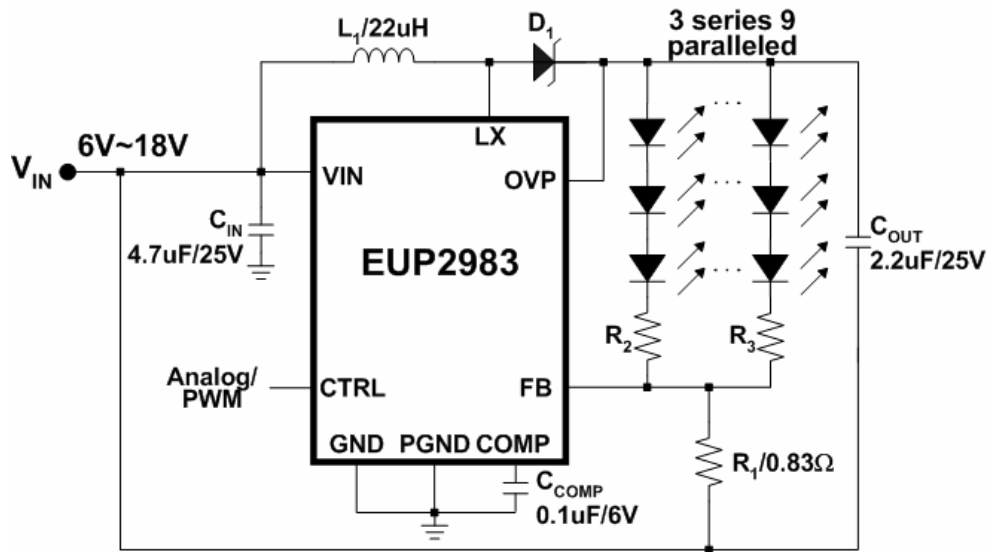

Figure 2. WLED Backlight Application

Pin Configurations

Package Type	Pin Configurations
TDFN-8	<p>TOP VIEW</p>

Pin Description

PIN	TDFN-8	DESCRIPTION
1	PGND	Power Ground
2	IN	Input Supply Voltage
3	CTRL	Brightness Control Input. LED brightness is controlled by the voltage applied to CTRL. Varying the voltage from 0.24V to 1.68V adjusts the brightness from dim to bright, respectively. Any voltage above 1.68V does not increase brightness.
4	FB	Current-Sense Feedback Input. Connect a resistor from FB to IN to set the LEDs bias current. The voltage $(V_{FB}-V_{IN})$ regulates to $V_{CTRL} / 10$ or 168mV, whichever is lower.
5	COMP	Compensation Input. Connect a 0.1µF capacitor ( $C_{COMP}$ ) from COMP to GND. $C_{COMP}$ stabilizes the converter and controls soft-start. $C_{COMP}$ discharges to GND when in shutdown.
6	GND	Analog Ground.
7	OVP	Over voltage Sense. When $V_{OVP}$ is greater than 32V, the internal N-channel MOSFET turns off until $V_{OVP}$ drops below 30V, then the IC re-enters soft-start. Connect a 2.2µF capacitor from OVP to PGND.
8	LX	Inductor Connection. This pin is high impedance during shutdown.

Ordering Information

Order Number	Package Type	Marking	Operating Temperature Range
EUP2983JIR1	TDFN-8	xxxxx P2983	-40 °C to +85°C

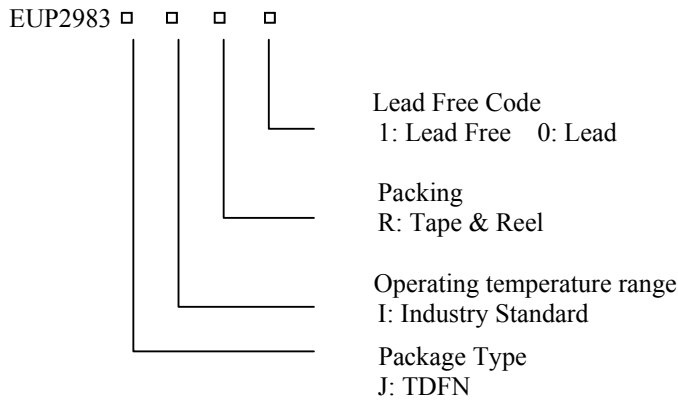

Block Diagram

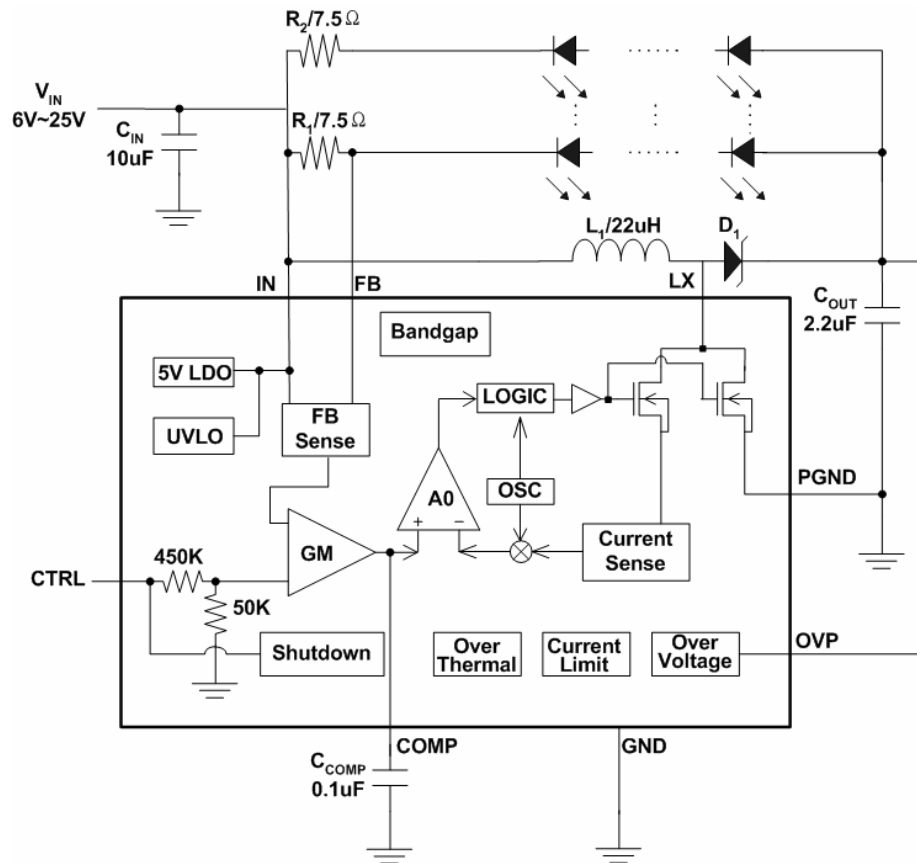

Figure 3.

**Absolute Maximum Ratings (1)**

■	IN to GND -----	-0.3V to 31V
■	PGND,GND -----	-0.3V to 0.3V
■	FB,LX,OVP to GND -----	-0.3V to 34V
■	COMP,CTRL to GND -----	-0.3V to 6V
■	I <sub>LX</sub> -----	2A
■	Package Thermal Resistance	
	TDFN-8,θ <sub>JA</sub> -----	50°C/W
■	Junction Temperature -----	150°C
■	Lead Temperature (Soldering, 10sec.) -----	260°C
■	Storage Temperature Range -----	-65°C to +150°C

**Recommend Operating Conditions (2)**

■	Supply Voltage , V <sub>IN</sub> -----	6V to 25V
■	Operation Temperature Range -----	-40°C to +85°C

Note (1): Stress beyond those listed under “Absolute Maximum Ratings” may damage the device.

Note (2): The device is not guaranteed to function outside the recommended operating conditions.

**Electrical Characteristics**

(V<sub>IN</sub>=8.4V, L<sub>1</sub>=22uH, C<sub>IN</sub>=10μF, C<sub>OUT</sub>=2.2μF, C<sub>COMP</sub>=0.1μF, R<sub>1</sub>=7.5, V<sub>CTRL</sub>=1V, T<sub>A</sub>=-40°C to +85°C.

Refer to Figure 2. Unless otherwise noted. Typical values are at T<sub>A</sub>= +25°C)

Parameter	Conditions	EUP2983			Unit
		Min	Typ	Max.	
Supply Voltage		6		25	V
UVLO Threshold	Rising	4.8	5	5.2	V
	Falling	4.5	4.7	4.9	V
Quiescent Current	Continuous Switching		1.2	1.8	mA
	Shutdown V <sub>CTRL</sub> =0		120	200	uA
OVLO Threshold	Rising		32		V
	Falling		30		V
OVP Input Bias Current	V <sub>OVP</sub> =30V, V <sub>CTRL</sub> >0.24V	20	40	60	μA
	V <sub>OVP</sub> =V <sub>IN</sub> , V <sub>CTRL</sub> =GND			1	μA
<b>Error Amplifier</b>					
CTRL to FB Regulation	V <sub>CTRL</sub> =1V, V <sub>IN</sub> =8.4V, Temp=25)	90	100	110	mV
CTRL Input Resistance	V <sub>CTRL</sub> ≤1V	200	500	800	KΩ
CTRL Dual-Mode Threshold	Rising and Falling	100	180	240	mV
CTRL Shutdown Enable Delay			8.2		ms
FB-to-COMP Transconductance	V <sub>COMP</sub> =1V		52		μs
<b>Oscillator</b>					
Operating Frequency		0.75	1.0	1.25	MHz
Maximum Duty Cycle	V <sub>CTRL</sub> =3V, V <sub>FB</sub> =V <sub>IN</sub>	90	92	95	%
<b>N-Channel Switch</b>					
LX On-Resistance			0.5	1	Ω
LX Current Limit	Duty Cycle=90%	0.8	1.4	2	A

Typical Operating Characteristics

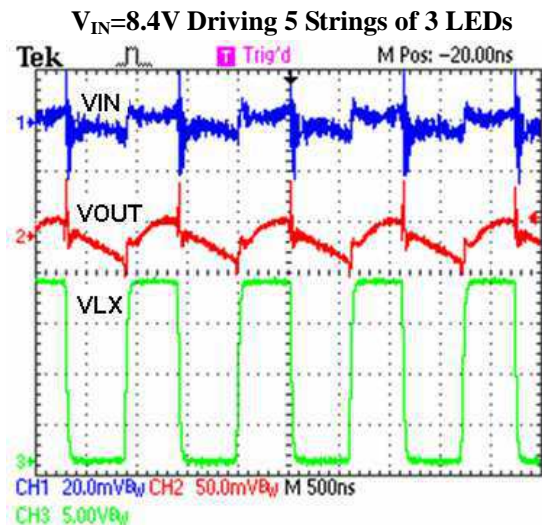
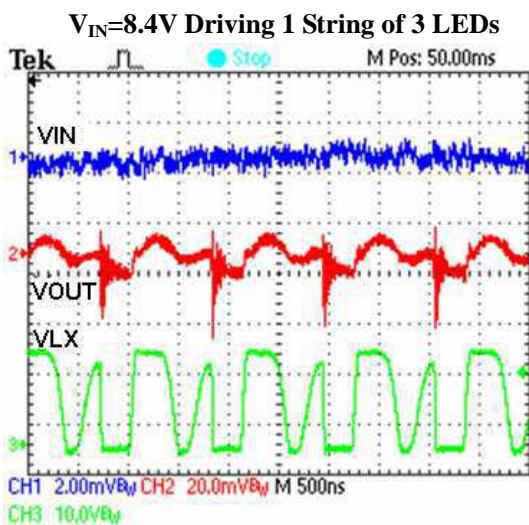
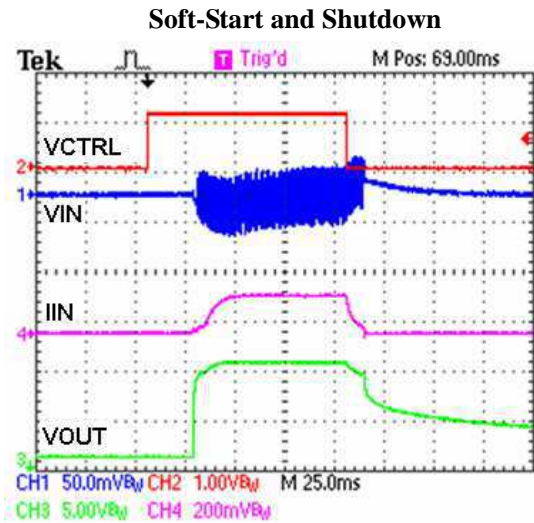
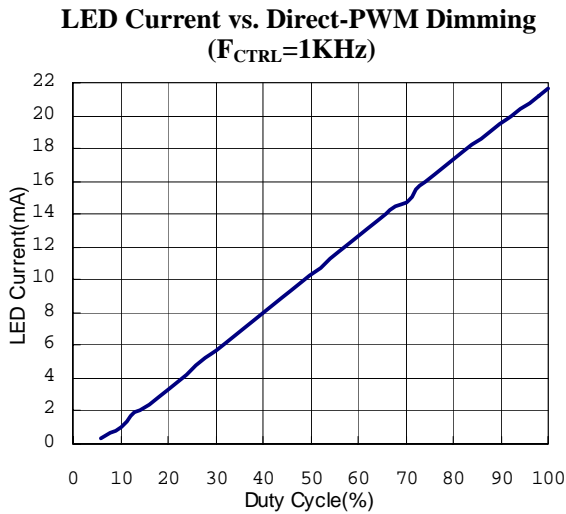
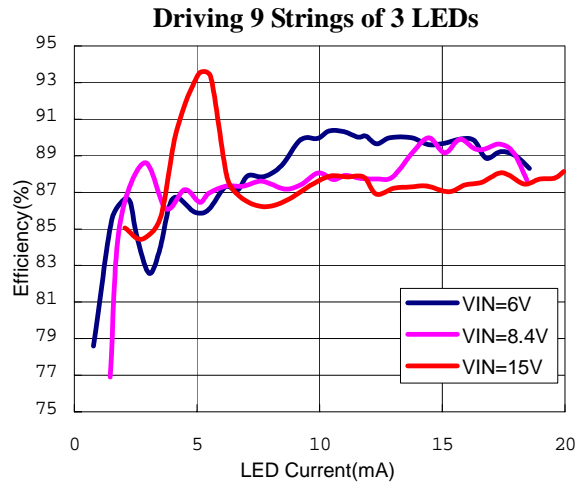
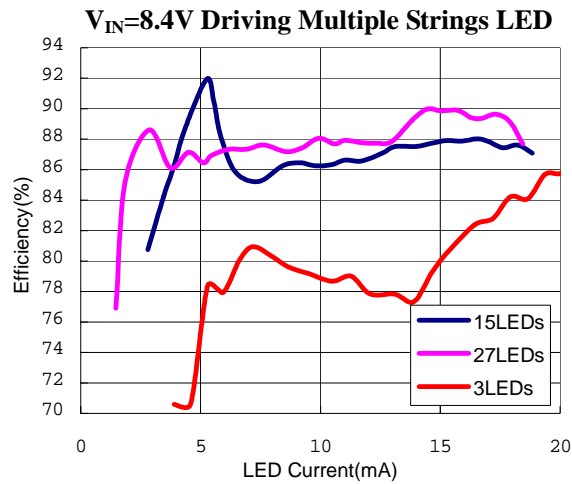

Typical Operating Characteristics (continued)

$V_{IN}=8.4V$  Driving 9 Strings of 3 LEDs

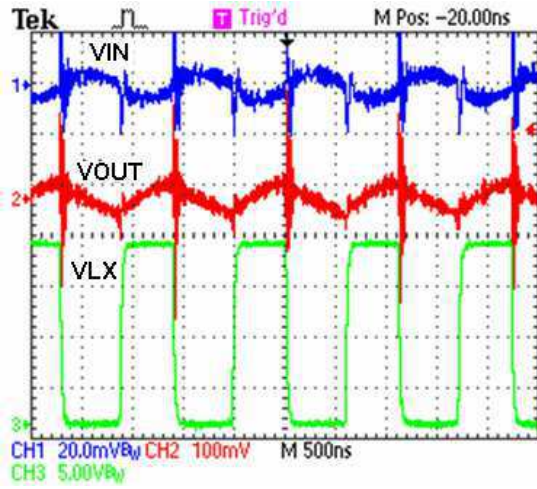

$V_{IN}=8.4V$  CTRL Step Response

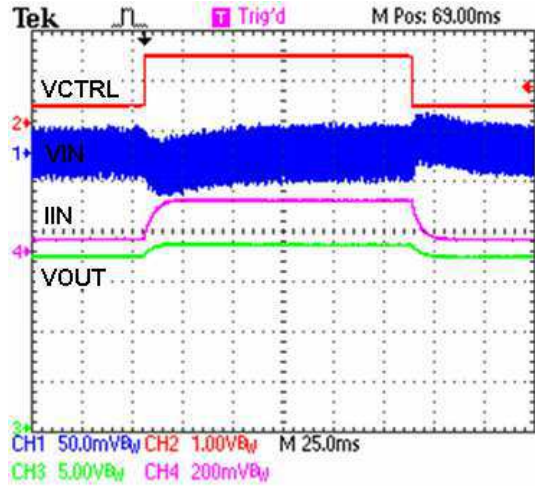

Direct-PWM Dimming Waveform  
( $F_{CTRL}=1KHz$ )

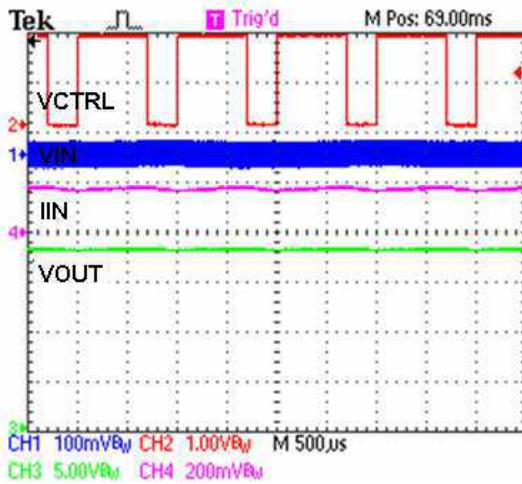

Direct-PWM Dimming Waveform  
( $F_{CTRL}=100KHz$ )

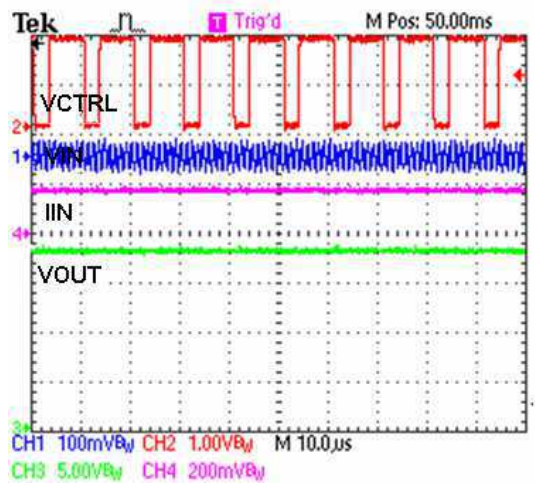

## Application Information

### Soft-Start

The EUP2983 attains soft-start by charging  $C_{COMP}$  gradually with a current source. When  $V_{COMP}$  rises above 1.25V, the internal MOSFET begins switching at an incremental duty cycle. When  $V_{COMP}$  rises above 2.25V, the duty cycle is at its maximum. See the *Typical Operating Characteristics* for an example of soft-start operation.

### Shutdown

The EUP2983 enters shutdown when  $V_{CTRL}$  is less than 100mV for more than 8.2ms. In shutdown, supply current is reduced to 150 $\mu$ A by powering down the entire IC except for the CTRL voltage-detection circuitry and internal regulator.  $C_{COMP}$  is discharged during shutdown, allowing the device to reinitiate soft-start when it is enabled. Typical shutdown timing characteristics are shown in the *Typical Operating Characteristics*.

### Overvoltage Protection

Overvoltage lockout (OVLO) occurs when  $V_{OUT}$  is above 32V. The protection circuitry stops the internal MOSFET from switching and causes  $V_{COMP}$  to decay to 0V. The device comes out of OVLO and into soft-start when  $V_{OUT}$  falls below 30V.

In normal operation, EUP2983  $V_{OUT}$  calculates as follows:

$$V_{OUT} = V_{IN} + V_{FB} + V_{LED} \times K$$

Where

$K$ -----number of LEDs in each string

$V_{IN}$ -----input voltage

$V_{FB}$ -----feedback voltage

$V_{LED}$ -----a LED forward voltage

### Adjusting LED Current

Adjusting the EUP2983's output current changes the brightness of the LEDs. An analog input CTRL and the sense-resistor value set the output current. Output current is given by:

$$I_{LED} = \frac{V_{CTRL}}{10 \times R_{SENSE}}$$

The  $V_{CTRL}$  voltage range for adjusting output current is 0.24V to 1.68V. To set the maximum current, calculate  $R_{SENSE}$  when  $V_{CTRL}$  is at its maximum as follows:

$$R_{SENSE} = \frac{1.68}{10 \times I_{LED(MAX)}}$$

Power dissipation in  $R_{SENSE}$  is typically less than 10mW, making a standard chip resistor sufficient.

### PWM Dimming Control

CTRL is also used as a digital input allowing LED brightness control with a logic-level PWM signal applied directly to CTRL. The frequency range is from 200Hz to 200kHz, while 0% duty cycle corresponds to zero current and 100% duty cycle corresponds to full current. The error amplifier and compensation capacitor form a lowpass filter so PWM dimming results in DC current to the LEDs without the need for any additional RC filters; see the *Typical Operating Characteristics*.

### Capacitor Selection

The exact values of input and output capacitors are not critical. The typical value for the input capacitor is 10 $\mu$ F and the typical value for the output capacitor is 2.2 $\mu$ F. Larger value capacitors can be used to reduce input and output ripple, but at the expense of size and higher cost.  $C_{COMP}$  stabilizes the converter and controls soft-start. Connect a 0.1 $\mu$ F capacitor from COMP to GND.

### Inductor Selection

Inductor values range from 10 $\mu$ H to 47 $\mu$ H. A 22 $\mu$ H inductor optimizes the efficiency for most applications while maintaining low 50mV<sub>P-P</sub> input ripple. To prevent core saturation, ensure that the inductor-saturation current rating exceeds the peak inductor current for the application. Calculate the peak inductor current with the following formula:

$$I_{PEAK} = \frac{V_{OUT(MAX)} \times I_{LED(MAX)}}{0.9 \times V_{IN(MIN)}} + \frac{V_{IN(MIN)} \times 0.9\mu s}{2 \times L}$$

### Schottky Diode Selection

The EUP2983's high switching frequency demands a high-speed rectification diode (D1) for optimum efficiency. A Schottky diode is recommended due to its fast recovery time and low forward-voltage drop. Ensure that the diode's average and peak current rating exceed the average output current and peak inductor current. In addition, the diode's reverse breakdown voltage must exceed  $V_{OUT}$ . The RMS diode current can be calculated from:

$$I_{DIODE(RMS)} = \sqrt{I_{OUT} \times I_{PEAK}}$$

### PC Board Layout

Due to fast switching waveforms and high-current paths, careful PC board layout is required. An evaluation kit is available to speed design. When laying out a board, minimize trace lengths between the IC and  $R_{SENSE}$ , the inductor, the diode, the input capacitor, and the output capacitor. Keep traces short, direct, and wide. Keep noisy traces, such as the LX node trace, away from FB. The IN bypass capacitor ( $C_{IN}$ ) should be placed as close to the IC as possible. PGND and GND should be connected directly to the exposed paddle underneath the IC. The ground connections of  $C_{IN}$  and  $C_{OUT}$  should be as close together as possible. The traces from IN to the inductor and from the Schottky diode to the LEDs may be longer.

Packaging Information

TDFN-8

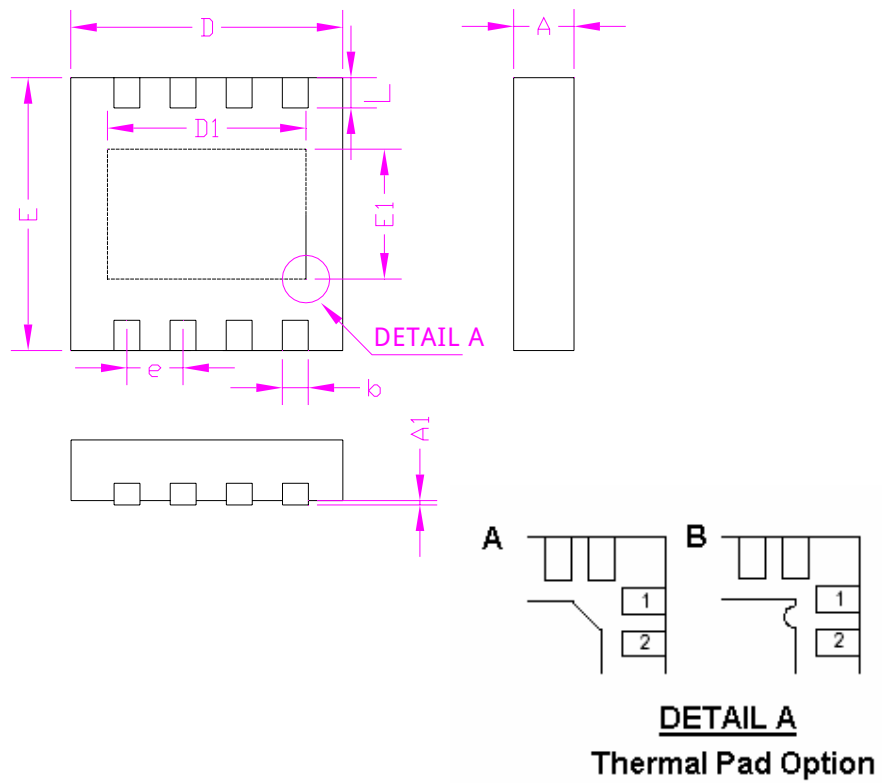

SYMBOLS	MILLIMETERS		INCHES	
	MIN.	MAX.	MIN.	MAX.
A	0.70	0.80	0.028	0.031
A1	0.00	0.05	0.000	0.002
b	0.20	0.40	0.008	0.016
D	2.90	3.10	0.114	0.122
D1	2.30		0.090	
E	2.90	3.10	0.114	0.122
E1	1.50		0.059	
e	0.65		0.026	
L	0.25	0.45	0.010	0.018