

White LED Step-Up Converter In TSOT-23 Package

DESCRIPTION

The EUP2518 is a constant current step-up converter specifically designed to drive white LEDs. The Step-up converter topology allows series connection of the white LEDs so the LED currents are identical for uniform brightness. The EUP2518 switches at 1.1MHz, allowing the use of tiny external components. The output capacitor can be as small as 0.22uF, saving space and cost versus alternative solutions. A low 104mV feedback voltage minimizes power loss in the current setting resistor for better efficiency. EUP2518 is enhanced with Soft-Start function and that could significantly reduce noise induced by capacitor.

The EUP2518 is available in low profile TSOT23-6 package.

FEATURES

- 2.6V to 5.5V Input Range
- 27V Output with Over Voltage Protection
- High Efficiency :87 % Typical
- Internal Soft-Start
- PWM Dimming Control
- Internal High Power 30V MOSFET Switch
- Fast 1.1MHz Switching Frequency
- Small, Low-Profile Inductors and Capacitors
- TSOT23-6 Package
- RoHS Compliant and 100% Lead (Pb)-Free

APPLICATIONS

- Mobile Phone
- Digital Still Camera
- PDAs, Handheld Computers
- MP3 Players
- GPS Receivers

Typical Application Circuit

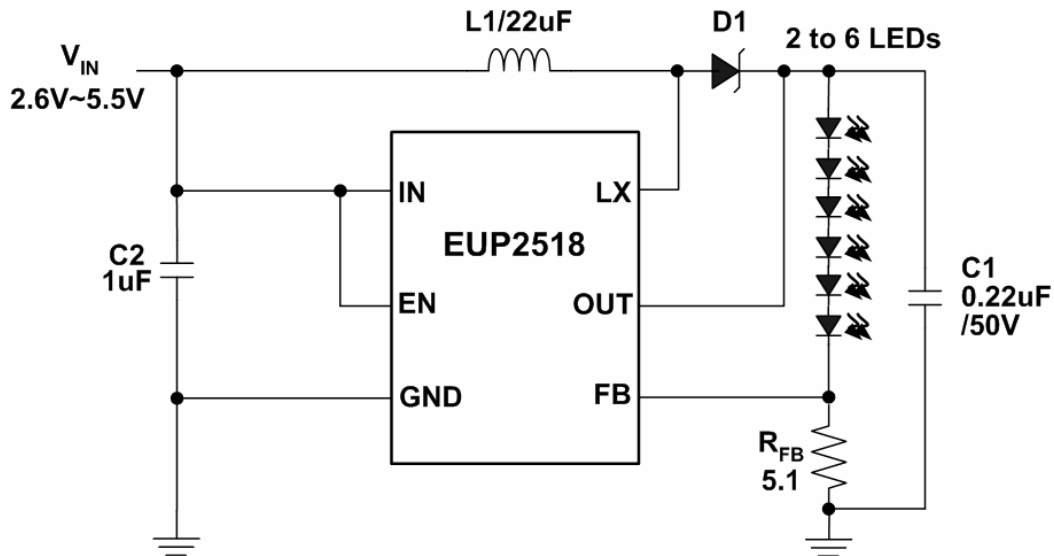

Figure 1. White LED Application

Pin Configurations

Package Type	Pin Configurations
TSOT23-6	<p style="text-align: center;"> IN OUT EN 6 5 4 ● 1 2 3 LX GND FB </p>

Pin Description

PIN	TSOT23-6	DESCRIPTION
LX	1	Switch Pin. Connect inductor/diode here. Minimize trace area at this pin to reduce EMI.
GND	2	Common Ground
FB	3	Feedback Pin. Reference voltage is 104mV. Connect cathode of lowest LED and resistor here. Calculate resistor value according to the formula: $R_{FB} = 104 / I_{LED}$
EN	4	Chip Enable Pin. Connect to 1.4V or higher to enable device, 0.3V or less to disable device.
OUT	5	Overvoltage Sense. When V_{OUT} is greater than 27V, the internal N-channel MOSFET turns off until V_{OUT} drops below 25V, then the IC reenters start. Connect a 0.22uF capacitor from OUT to GND.
IN	6	Input Supply Voltage

Ordering Information

Order Number	Package Type	Marking	Operating Temperature Range
EUP2518OIR1	TSOT23-6	50 □ □ □ □	-40 °C to 85°C

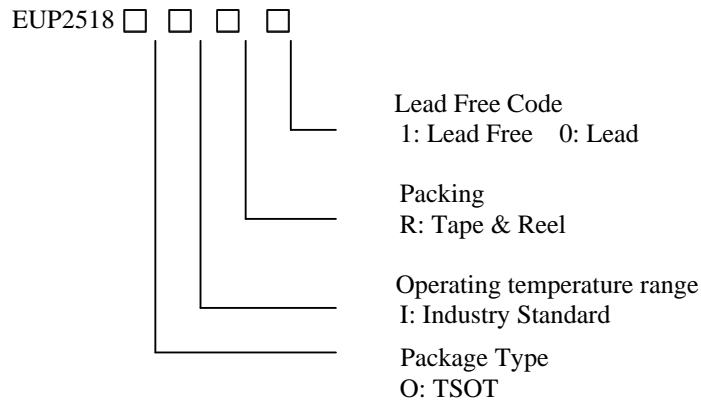

Block Diagram

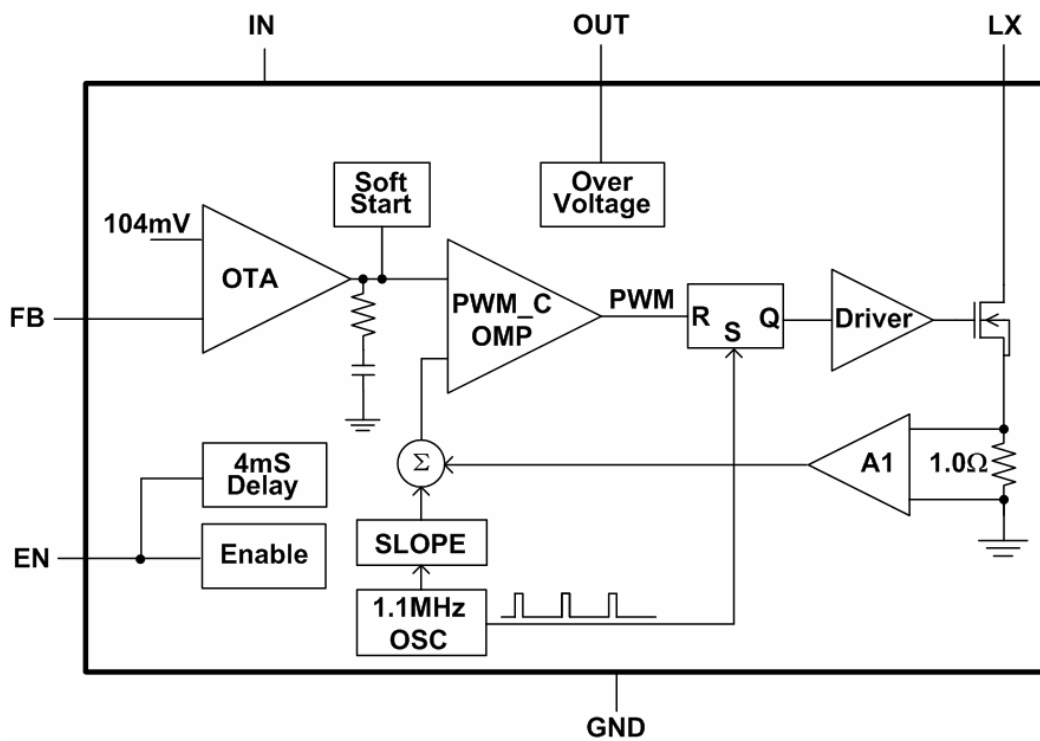

Figure 2.

Absolute Maximum Ratings

- Supply Voltage, V_{IN} ----- -0.3V to 6V
- LX,OUT ----- -0.3V to 30V
- The Other Pins ----- -0.3V to 6V
- Package Thermal Resistance
TSOT23-6, θ_{JA} ----- 220°C/W
- Maximum Junction Temperature ----- 125°C
- Lead Temperature (Soldering, 10sec.) ----- 260°C
- Storage Temperature Range ----- -65°C to 150°C

Operating Conditions

- Junction Temperature Range ----- -40°C to 125°C
- Supply Voltage, V_{IN} ----- 2.6V to 5.5V

Electrical Characteristics

($V_{IN}=3.6V$, $V_{OUT}=18V$, $C_{OUT}=0.22\mu F$, $C_{IN}=1\mu F$, $R_{FB}=5.1\Omega$, $T_A=-40^\circ C$ to $85^\circ C$. Unless otherwise noted. Typical values are at $T_A=25^\circ C$)

Symbol	Parameter	Conditions	EUP2518			Unit
			Min	Typ	Max.	
	Supply Voltage		--	--	6	V
UVLO	Under Voltage Lock Out	V_{IN} Rising	2.2	2.4	2.6	V
		V_{IN} Falling	1.95	2.15	2.35	
	Maximum Output Voltage	No Switching	--	--	30	V
I_{CC1}	Supply Current	$V_{CC}=6V$, Continuous Switching	--	0.8	1.3	mA
I_{CC2}	Quiescent Current	$V_{CC}=6V$, $FB=1.3V$, No Switching	--	115	150	μA
I_{CC3}	Shutdown current	$V_{CC}=6V$, $V_{EN}<0.3V$	--	0.1	1	μA
Oscillator						
Fosc	Operation Frequency		0.8	1.1	1.3	MHz
Dmax	Maximum Duty Cycle		89	92	96	%
Reference Voltage						
V_{FB}	Feedback Voltage		94	104	114	mV
MOSFET						
$R_{DS(ON)}$	On resistance of MOSFET		--	1	1.5	Ω
I_{LX}	Current Limit		0.4	0.8	1.2	A
Control and Protection						
V_{EN1}	Shutdown Voltage		0.3	0.7	--	V
V_{EN2}	Enable Voltage		--	0.7	1.4	V
I_{EN}	EN Pin Pull Low Current		--	--	0.1	μA
OVP	OVP Threshold	Falling	24.5	25.7	26.5	V
		Rising	26.1	27.3	28.1	

Typical Operating Characteristics

Efficiency vs LED Current

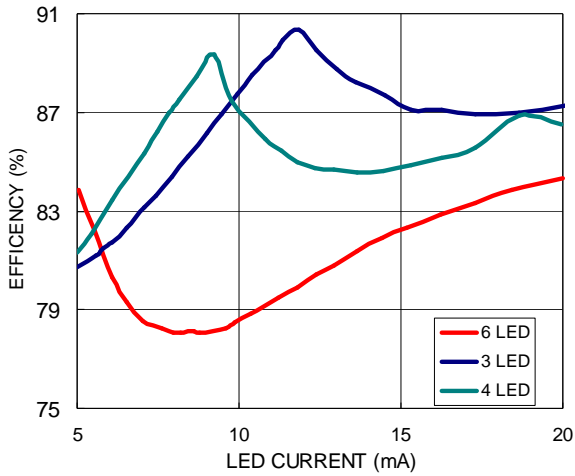

Startup Waveforms into an Open Load

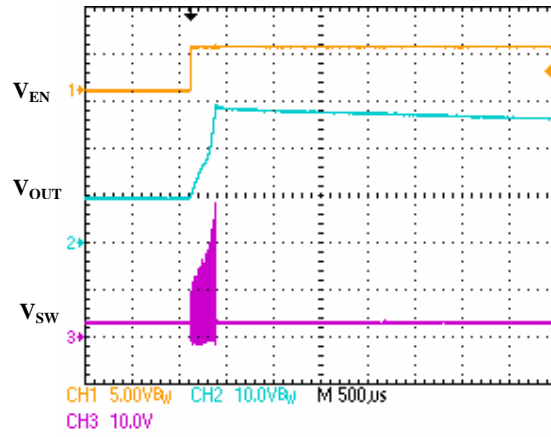

Startup Waveforms

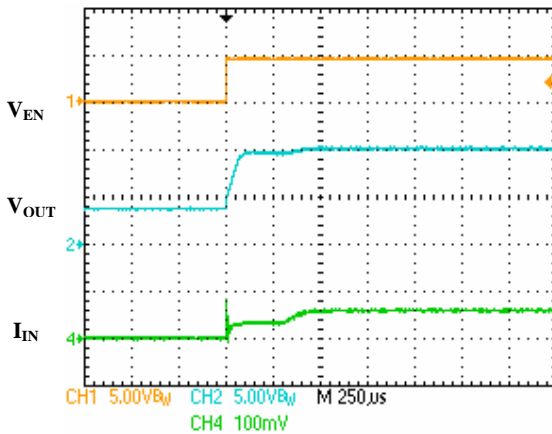

Steady State Operation (V_{IN}=3.6V, 3 LEDs, 20mA)

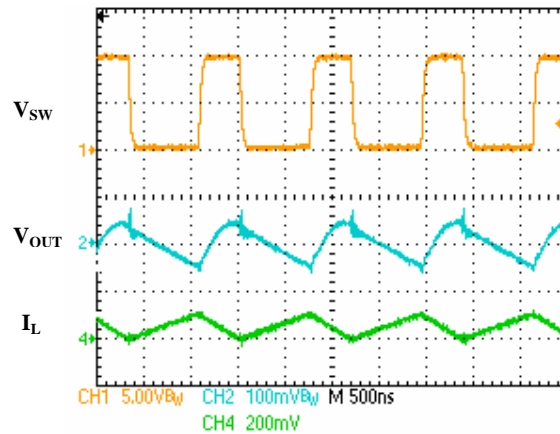

1KHz 50% Duty Cycle PWM Dimming

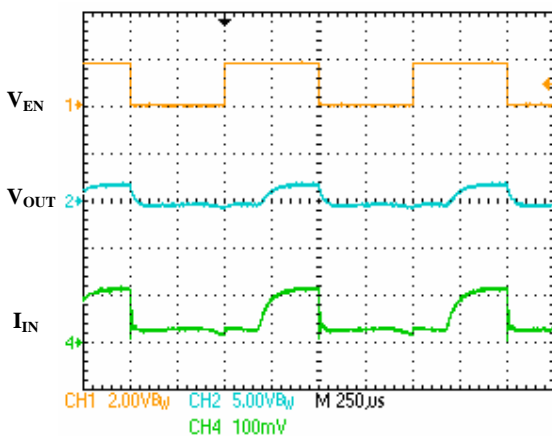

10KHz 50% Duty Cycle PWM Dimming

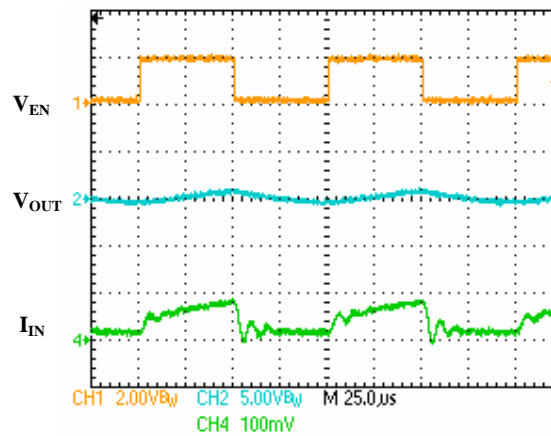

Application Information

LED Current Control

The EUP2518 regulates the LED current by setting the current sense resistor (R_{FB}) connecting to feedback and ground. The internal feedback reference voltage is 104mV. The LED current can be set from following equation easily.

$$R_{FB} = \frac{104mV}{I_{LED}} \text{-----(1)}$$

In order to have an accurate LED current, precision resistors are preferred (1% is recommended). The table for R_{FB} selection is shown below.

R _{FB} Resistor Value selection	
I _{LED} (mA)	R _{FB} (Ω)
5	21
10	10.4
15	6.93
20	5.2

CAP and Inductor Selection

The recommended value of inductor for 2 to 6 WLEDs applications are 10μH to 47μH. Small size and better efficiency are the major concerns for portable device. A 22μH inductor with low DCR (Inductor resistance) is recommended to improve efficiency. To avoid inductor saturation current rating should be considered. A 1μF ceramic capacitor is recommended for the input capacitance in the real system, and a larger capacitor will get smaller input voltage ripple. A 0.22uF output ceramic capacitor is sufficient for most applications.

Dimming Control

a. Using a PWM Signal to EN Pin

For controlling the LED brightness, the EUP2518 can perform the dimming control by applying a PWM signal to EN pin. The internal soft-start and wide range dimming frequency from 100Hz to 100KHz can insignificantly reduce audio noise when dimming. The average LED current is proportional to the PWM signal duty cycle. The magnitude of the PWM signal should be higher than the maximum enable voltage of EN pin, in order to let the dimming control perform correctly.

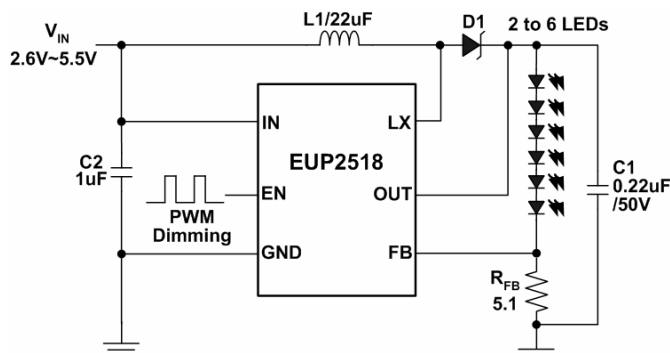

Figure 3. PWM Dimming Control Using the EN Pin

b. Using a DC Voltage

Using a variable DC voltage to adjust the brightness is a popular method in some applications. The dimming control using a DC voltage circuit is shown in Figure 4. According to the Superposition Theorem, as the DC voltage increases, the voltage contributed to V_{FB} increases and the voltage drop on R_{FB} decreases, i.e. the LED current decreases. For example, if the V_{DC} range is from 0V to 2V, the selection of resistors in Figure 4 sets dimming control of LED current from 20mA to 0mA.

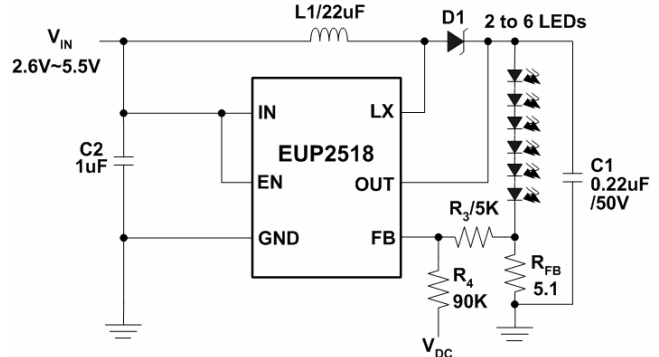

Figure 4. Dimming Control Using a DC Voltage

c. Using a Filtered PWM signal

Another common application is using a filtered PWM signal as an adjustable DC voltage for LED dimming control. A filtered PWM signal acts as the DC voltage to regulate the output current. In this circuit, the output ripple depends on the frequency of PWM signal. For smaller output voltage ripple (<100mV), the recommended frequency of 2V PWM signal should be above 2kHz. To fix the frequency of PWM signal and change the duty cycle of PWM signal can get different output current. According to the application circuit of Figure 5, output current is from 20.5mA to 5.5mA by adjusting the PWM duty cycle from 10% to 90%.

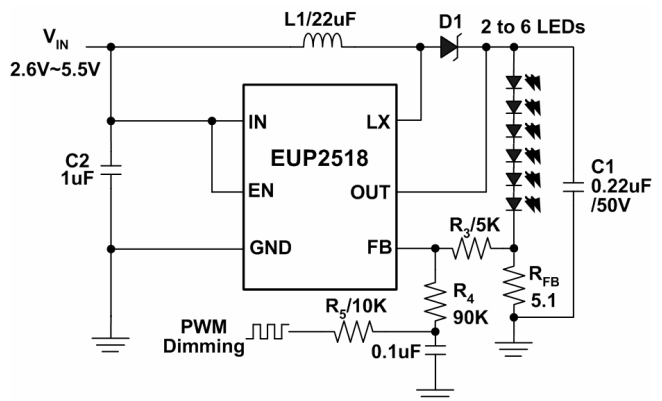
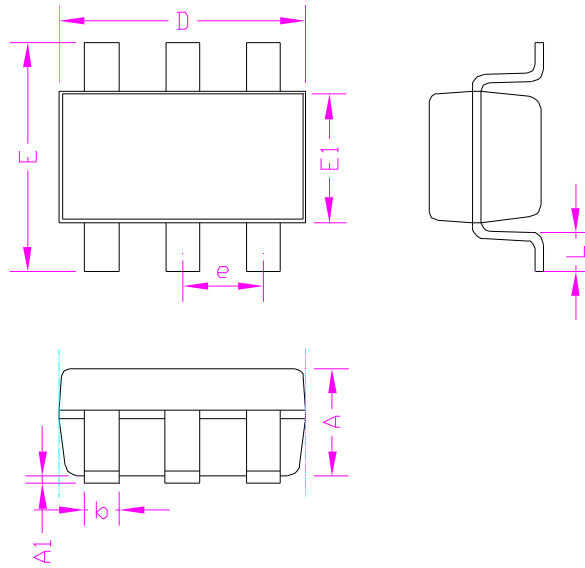

Figure 5. Filtered PWM Signal for LED Dimming Control

Layout Considerations

The input bypass capacitor C2, as shown in Figure 1, must be placed close to the IC. This will reduce copper trace resistance which effects input voltage ripple of the IC. The output capacitor, C1, should also be placed close to the IC. Any copper trace connections for the C1 capacitor can increase the series resistance, which directly effects output voltage ripple. The feedback resistors R_{FB} should be kept close to the FB pin to minimize copper trace connections that can inject noise into the system. The ground connection for the feedback resistor network should connect directly to GND pin. Trace connections made to the inductor and schottky diode should be minimized to reduce EMI and increase overall efficiency.

Packaging Information**TSOT23-6**

SYMBOLS	MILLIMETERS		INCHES	
	MIN.	MAX.	MIN.	MAX.
A	-	1.00	-	0.039
A1	0.00	0.15	0.000	0.006
b	0.30	0.50	0.012	0.020
D	2.90		0.114	
E1	1.60		0.063	
e	0.95		0.037	
E	2.60	3.00	0.102	0.118
L	0.3	0.60	0.012	0.024