

LINE MATCHING TRANSFORMER**P3126****Features**

- * 14.6mm seated height
- * Vacuum encapsulated
- * Compliant with EN 50020 and EN 60950

Applications

- * Potentially explosive atmospheres
- * Telecommunications
- * Telemetry
- * Line matching
- * Instrumentation

DESCRIPTION

P3126 is a line matching transformer for applications where high performance and safety isolation to the most exacting international standards are required in a compact case size.

In conjunction with external protection (e.g. fuses, zener diodes, etc.) the device is compliant with EN 50020 for peak rated voltage $\leq 375V$.

Signal performance is equivalent to ETAL® P1200.

SPECIFICATIONS

Electrical

At T = 25°C and as reference circuit Fig. 2 unless otherwise stated.

Parameter	Conditions	Min	Typ	Max	Units
Insertion loss	f = 2kHz, R _L = 560Ω	-	-	1.5	dB
Frequency response	LF-3dB cutoff	-	-	50	Hz
	HF-3dB cutoff	10	-	-	kHz
	200Hz – 4kHz	-	-	±0.2	dB
Return loss	200Hz – 4kHz	18	-	-	dB
Distortion ⁽¹⁾	0dBm in line, 3rd Harmonic f = 450Hz	-	-72	-60	dBm
Balance	DC - 5kHz Method TG25	80	-	-	dB
Saturation	Excitation 50Hz 250Vrms Output voltage across line	-	-	10	Vrms
		-	-	65	Vpeak
Voltage Isolation ⁽²⁾	50Hz	3.88	-	-	kVrms
	DC	5.5	-	-	kV
Operating range:	Ambient temperature	-10	-	+70	°C
		-40	-	+125	°C
		-	-	95	%R.H.

Lumped equivalent circuit parameters as Fig. 1

DC resistance, R _{DC} ⁽³⁾	Sum of windings	120	-	148	Ω
Leakage inductance ΔL		-	17	-	mH
Shunt inductance L _p ⁽⁴⁾	-43dBm 200Hz	2.8	4	7	H
	-43dBm 1kHz	-	2	-	H
Shunt loss R _p ⁽⁴⁾	-43dBm 200Hz	5	-	-	kΩ
	-43dBm 1kHz	7	-	-	kΩ

Notes:

1. Third harmonic typically exceeds other harmonics by 20dB.
2. Components are 100% tested at 6.5 kVDC.
3. Caution: do not pass DC through windings. Telephone line current, etc must be diverted using choke or semiconductor line hold circuit.
4. At signal levels greater than -20dBm L_p will increase and R_p will decrease slightly but the effect is usually favourable to the return loss characteristic.

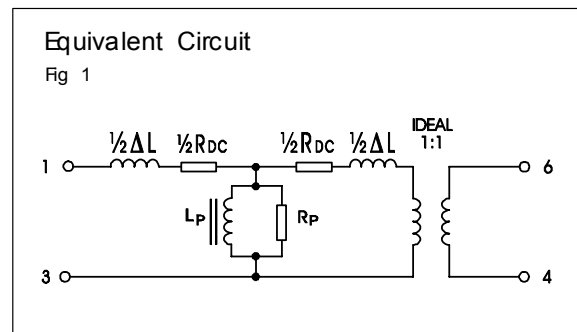

CONSTRUCTION

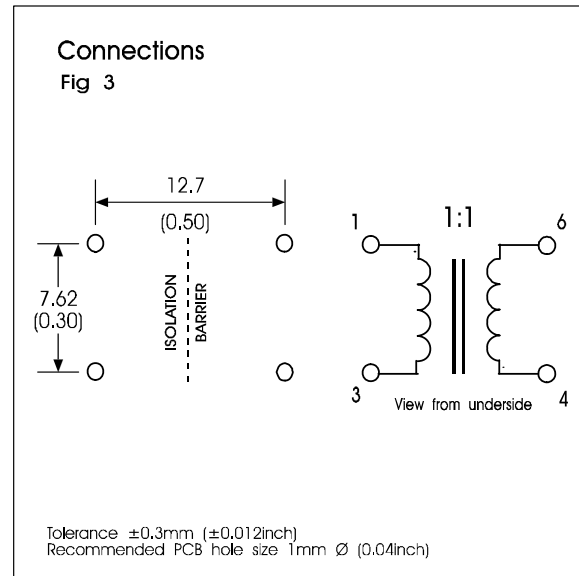
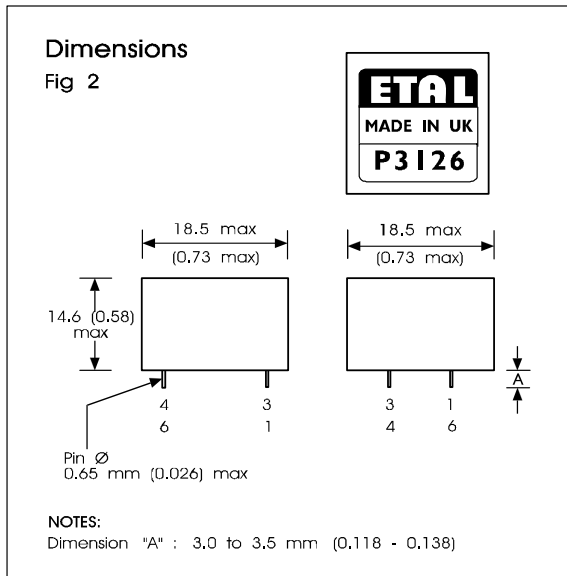

Dimensions shown are in millimetres (inches).
Geometric centres of outline and pin grid coincide within a tolerance circle of 0.6mm \varnothing .
Windings may be used interchangeably as primary or secondary.

EN 50020 para 7.1.2 Type 1(a) (side-by-side on separate slots of single piece moulding).

Fully vacuum encapsulated with hard epoxy resin totally enclosing all internal parts.

Critical Distances

- (a) Distance through bobbin dividing fillet. $\geq 1.0\text{mm}$
- (b) Distance through bobbin walls to conductive core (Each winding). $\geq 0.5\text{mm}$

- (c) Distance between highest point of each winding (including lead-outs) and top of dividing fillet. $\geq 1.0\text{mm}$
- (d) Distance between highest point of each winding (including lead-outs) to conductive core through encapsulant. $\geq 1.0\text{mm}$
- (e) Distance through potting box to conductive core. $\geq 0.7\text{mm}$
- (f) Creepage/clearance (in air). $\geq 11.0\text{mm}$

ABSOLUTE MAXIMUM RATINGS

(Ratings of components independent of circuit).

Short term isolation voltage (15s)	4.6kVrms, 6.5 kVDC
DC current	100 μ A
Storage temperature	-40°C to +125°C
Lead temperature, 10s	260°C

COPYRIGHT

ETAL and P3126 are Trade Marks of Profec Technologies Ltd.

The Trade Mark ETAL is registered at the UK Trade Marks Registry.

Profec Technologies Ltd. is the owner of the design right under the Copyright Designs and Patents Act 1988 and no rights or licences are hereby granted or implied to any third party.

© 2000 Profec Technologies Ltd.
Reproduction prohibited



ISO 9001
FM 25326

ETAL Group Oy, Kuormatie 14, FIN-03101, Nummela
Telephone: +358 (0)20 7500 330 Fax: +358 (0)20 7500 333
Website: www.etalgroup.com Email: etalgroup@egruppen.com