



# ELM712 LED Runner

## Description

The ELM712 is a handy circuit for controlling up to five LEDs in novelty devices. One pushbutton press is all it takes to initiate about 15 seconds of LED activity, before the circuit reverts back to its very low current standby mode.

All of the logic required for circuit operation is contained wholly within this 8 pin integrated circuit. Normally only a pushbutton, the LEDs, and a battery are all that are needed for a complete circuit. At higher voltages, a single current limiting resistor may be required to limit LED current.

The ELM712 drives each LED output in a sequential fashion, at approximately 10 Hz. By only driving one output at a time, peak current and thus battery requirements are reduced.

## Applications

- Campaign buttons
- Battery operated toys
- Dress ties
- Signs
- Holiday Ornaments

## Features

- Low power CMOS design
- Wide supply range - 3.0 to 5.5 volt operation
- Auto-off mode conserves batteries
- Single push-button to activate
- Direct drive high current outputs
- No external timing components required

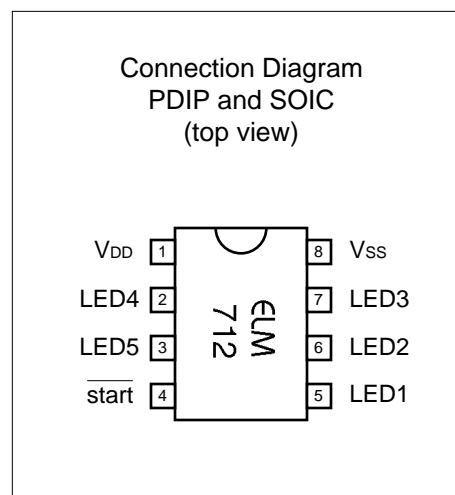

## Block Diagram

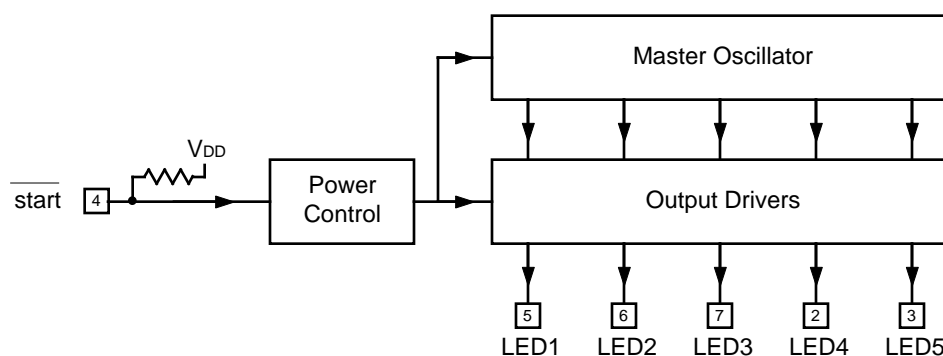



Pin Descriptions

VDD (pin 1)

This pin is the positive supply pin, and should always be the most positive point in the circuit. Internal circuitry connected to this pin is used to provide power on reset of the microprocessor, so an external reset signal is not required. Refer to the Electrical Characteristics section for further information.

LED1, LED2, LED3, LED4 and LED5 (pins 5, 6, 7, 2 and 3 respectively)

These are the five active high LED drive outputs. They are energized in the order listed for approximately 20msec each, at a rate of 10Hz. Each output is capable of sourcing a maximum of 25mA of current, when the ELM712 is operated at the maximum supply level.

start (pin 4)

Momentarily connecting this pin to Vss will initiate an LED sequence that typically lasts for about 15 seconds. After this time, the circuit will revert back to the low power mode, waiting for another start signal. The circuit automatically senses a 'stuck button' condition as well and powers down the internal circuits, but not the internal pull-up resistor.

Vss (pin 8)

Circuit common is connected to this pin. This is the most negative point in the circuit.

Ordering Information

These integrated circuits are available in either the 300 mil plastic DIP format, or in the 200 mil SOIC surface mount type of package. To order, add the appropriate suffix to the part number:

300 mil Plastic DIP..... ELM712P      200 mil SOIC..... ELM712SM

Absolute Maximum Ratings

- Storage Temperature..... -65°C to +150°C
Ambient Temperature with Power Applied..... -40°C to +85°C
Voltage on VDD with respect to Vss..... 0 to +7.5V
Voltage on any other pin with respect to Vss..... -0.6V to (VDD + 0.6V)

Note:

Stresses beyond those listed here will likely damage the device. These values are given as a design guideline only. The ability to operate to these levels is neither inferred nor recommended.

All rights reserved. Copyright ©1999 Elm Electronics. Every effort is made to verify the accuracy of information provided in this document, but no representation or warranty can be given and no liability assumed by Elm Electronics with respect to the accuracy and/or use of any products or information described in this document. Elm Electronics will not be responsible for any patent infringements arising from the use of these products or information, and does not authorize or warrant the use of any Elm Electronics product in life support devices and/or systems. Elm Electronics reserves the right to make changes to the device(s) described in this document in order to improve reliability, function, or design.

## Electrical Characteristics

All values are for operation at 25°C and a 3V supply, unless otherwise noted. For further information, refer to note 1 below.

Characteristic	Minimum	Typical	Maximum	Units	Conditions
Supply Voltage, $V_{DD}$	3.0	3.0	5.5	V	
$V_{DD}$ rate of rise	0.05			V/ms	see note 2
Average Supply Current, $I_{DD}$		0.60	2.0	mA	During operation
		0.1	5	$\mu$ A	In low power (standby) mode
Start pin internal pullup resistance	470	750	1500	K $\Omega$	see note 3
LED Drive Current		9		mA	No series limiting resistor
		13		mA	200 $\Omega$ series limiting resistor
Output Pulse Duration		20		msec	any output

### Notes:

1. This integrated circuit is produced with a Microchip Technology Inc.'s PIC12C5XX as the core embedded microcontroller. For further device specifications, and possibly clarification of those given, please refer to the appropriate Microchip documentation.
2. This spec must be met in order to ensure that a correct power on reset occurs. It is quite easily achieved using most common types of supplies, but may be violated if one uses a slowly varying supply voltage, as may be obtained through direct connection to solar cells, or some charge pump circuits.
3. The value of the pullup resistance is both supply and temperature dependent.

## Example Application

Using the ELM712 is straightforward, requiring little explanation. Typically it is connected in a circuit as shown at the right. Pressing the start pushbutton once initiates a sequence of LED flashes that last approximately 15 seconds.

The value of the resistor shown depends on the voltage level that the circuit operates at. For the circuit shown, no resistor is normally used, and these points are jumpered out. For 5V operation, a value of about 150 to 300 ohms is generally inserted.

