

Marketing Bulletin

DATE: May 20, 2003
TO: Affected Customers
FROM: Mark Stoner
RE: Product Termination

To all concerned parties,

This bulletin is to notify all customers of the termination of the following Ecliptek series effective May 14th, 2003:

Series	Description	Recommended Replacement
E11C1	Four Pad SMD PECL Oscillator, 5V	E11J1 or E11W1
E13C1	Four Pad SMD PECL Oscillator, 3.3V	E13J1 or E13W1
E11C2	Six Pad SMD PECL Oscillator, 5V	E11J2 or E11W2
E13C2	Six Pad SMD PECL Oscillator, 3.3V	E13J2 or E13W2
E31C2	Six Pad SMD PECL VCXO, 5V	E31J2 or E31W2
E32C2	Six Pad SMD PECL VCXO, 3.3V	E32J2 or E32W2

Because of the circumstances surrounding this termination, there will be no end-of-life policy exercised. The series will be terminated with no purchasing or lifetime buy window available. All of us at Ecliptek Corporation apologize for any inconvenience this may have caused and can assure you we are taking measures to insure this will not happen again in the future.

Best Regards,

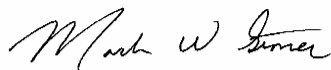

Mark W. Stoner
Director of Marketing
Ecliptek Corporation

E11C1 Series

- PECL Output Oscillators
- 5.0V supply voltage
- 4 pad ceramic SMD package with J-leads
- Stability to 20ppm
- Output Enable/Disable available
- Complementary Output available
- Available on Tape and Reel

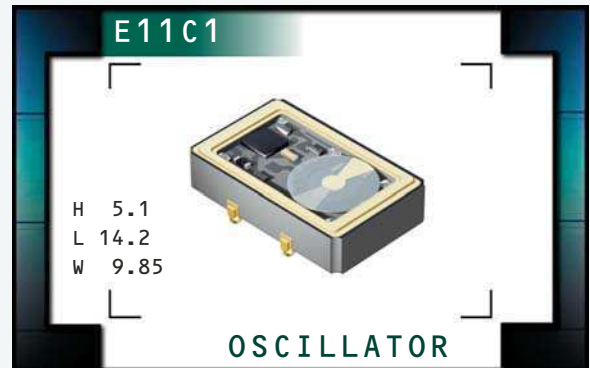

NOTES

ELECTRICAL SPECIFICATIONS

Frequency Range		19.440MHz to 212.500MHz
Operating Temperature Range		0°C to 70°C or -40°C to 85°C
Storage Temperature Range		-55°C to 125°C
Supply Voltage (V_{CC})		5.0V _{DC} ±5%
Input Current		100mA Maximum
Logic Type		100KH
Frequency Tolerance / Stability	Inclusive of Operating Temp Range, Supply Voltage, Load, and Aging @25°C over 10 years	±100ppm, ±50ppm, ±25ppm, or ±20ppm Maximum
Output Voltage Logic High (V_{OH})		$V_{CC}-1.025V_{DC}$ Minimum
Output Voltage Logic Low (V_{OL})		$V_{CC}-1.620V_{DC}$ Maximum
Rise Time / Fall Time	20% to 80% of waveform	2 nSeconds Maximum
Duty Cycle	at 50% of waveform	50 ±10(%) 50 ±5(%)
Load Drive Capability		50 Ohms into $V_{CC}-2.0V_{DC}$
Logic Control / Additional Output		No Connect, Enable/Disable, or Complementary Output
Enable/Disable Input Voltage	V_{IL} of $V_{CC}-1.475V_{DC}$ Maximum No Connection V_{IH} of $V_{CC}-1.165V_{DC}$ Minimum	Enables Output Enables Output Disables Output: Logic Low, Disables Complementary Output: Logic High
Start Up Time		10 mSeconds Maximum
RMS Phase Jitter	FJ = 12kHz to 20MHz	1 pSec Maximum

MANUFACTURER	CATEGORY	SERIES	PACKAGE	VOLTAGE	CLASS	REV. DATE
ECLIPTEK CORP.	OSCILLATOR	E11C1	CERAMIC	5.0V	0565	10/02

PART NUMBERING GUIDE

E11C1 F 2 C - 155.520M TR

FREQUENCY TOLERANCE & STABILITY/ OPERATING TEMPERATURE RANGE

C=±100ppm Maximum over 0°C to +70°C
 D=±50ppm Maximum over 0°C to +70°C
 E=±25ppm Maximum over 0°C to +70°C
 F=±20ppm Maximum over 0°C to +70°C
 G=±100ppm Maximum over -40°C to +85°C
 H=±50ppm Maximum over -40°C to +85°C

DUTY CYCLE

1=50% ±10%, 2=50% ±5%

AVAILABLE OPTIONS

Blank=Tubes
 TR=Tape and Reel (Standard)

FREQUENCY

LOGIC CONTROL/ADDITIONAL OUTPUT

A=No Connect
 B=Enable/Disable
 C=Complementary Output

MECHANICAL DIMENSIONS

ALL DIMENSIONS IN MILLIMETERS

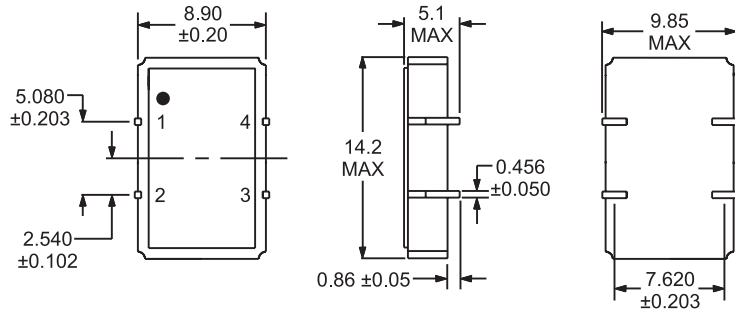

Pin 1: Complementary Output, No Connect, or Enable/Disable
 Pin 2: Case Ground Pin 3: Output Pin 4: Supply Voltage

SUGGESTED SOLDER PAD LAYOUT

ALL DIMENSIONS IN MILLIMETERS

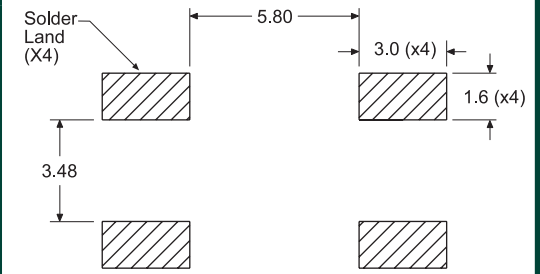

Tolerances = ±0.1

TAPE AND REEL DIMENSIONS

ALL DIMENSIONS IN MILLIMETERS

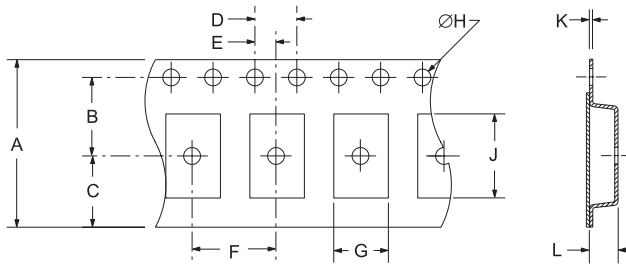

TAPE	A	B	C	D	E
	24 ±.3	11.5 ±.1	10.75 ±.1	4 ±.2	2 ±.1
F	G	H	J	K	L
12 ±.1	B0*	1.5 ±.1-0	A0*	.4 ±.05	K0*

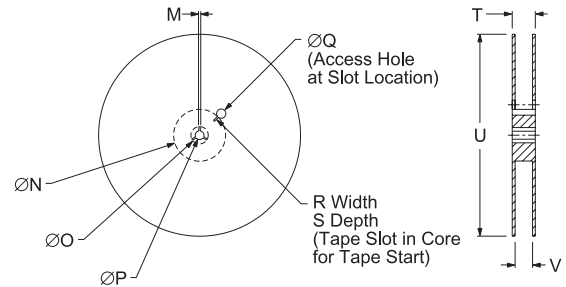

REEL	M	N	O	P	Q
	1.5 MIN	50 MIN	20.2 MIN	13 ±.2	40 MIN
R	S	T	U	V	QTY/REEL
2.5 MIN	10 MIN	30.4 MAX	360 MAX	24.4+2-0	1000

*Compliant to EIA 481A

ENVIRONMENTAL/MECHANICAL SPECIFICATIONS

Characteristic	Specification
Seal Integrity	Bubble test in Perfluorocarbon at +125°C ±5°C for 60 seconds minimum (internal crystal only).
Solderability	Sn63 Solder dip at +230°C ±5°C for 5 seconds/95% coverage.
Marking Permanency	10 Strokes with brush after 1 minute soak in solvent, 3 times.
Shock	Random drop on hard wooden plate 3 times from a height of 20cm.
Vibration	Frequency with an amplitude of 1.5mm sweeping between 10Hz to 55Hz within 1 minute (approximately) for 2 hours minimum on each axis (X, Y and Z) for a total of 6 hours.

MARKING SPECIFICATIONS

Line 1: ECLIPTEK
 Line 2: XX.XXX M
 — Frequency in MHz (5 Digits Maximum + Decimal)
 Line 3: XX Y ZZ
 — Week of Year
 — Last Digit of Year
 — Ecliptek Manufacturing Identifier

MANUFACTURER	CATEGORY	SERIES	PACKAGE	VOLTAGE	CLASS	REV. DATE
ECLIPTEK CORP.	OSCILLATOR	E11C1	CERAMIC	5.0V	OS65	10/02

E11C2 Series

- PECL Output Oscillators
- 5.0V supply voltage
- 6 pad ceramic SMD package with J-leads
- Stability to 20ppm
- Output Enable/Disable available
- Complementary Output available
- Available on Tape and Reel

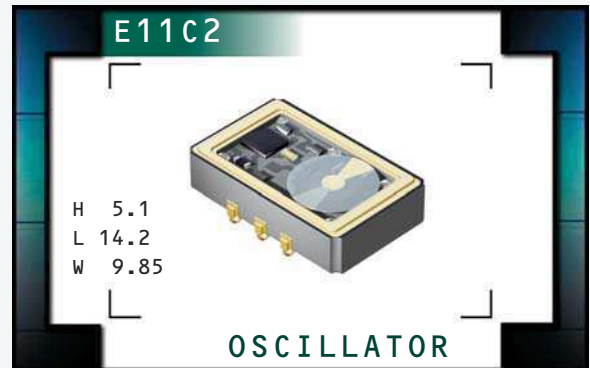

NOTES

ELECTRICAL SPECIFICATIONS

Frequency Range		19.440MHz to 212.500MHz
Operating Temperature Range		0°C to 70°C or -40°C to 85°C
Storage Temperature Range		-55°C to 125°C
Supply Voltage (V_{CC})		5.0V _{DC} ±5%
Input Current		100mA Maximum
Logic Type		100KH
Frequency Tolerance / Stability	Inclusive of Operating Temp Range, Supply Voltage, Load, and Aging @25°C over 10 years	±100ppm, ±50ppm, ±25ppm, or ±20ppm Maximum
Output Voltage Logic High (V_{OH})		V _{CC} -1.025V _{DC} Minimum
Output Voltage Logic Low (V_{OL})		V _{CC} -1.620V _{DC} Maximum
Rise Time / Fall Time	20% to 80% of waveform	2 nSeconds Maximum
Duty Cycle	at 50% of waveform	50 ±10(%) 50 ±5(%)
Load Drive Capability		50 Ohms into V _{CC} -2.0V _{DC}
Logic Control / Additional Output		No Connect, Enable/Disable, Complementary Output, or Complementary Output and Enable/Disable
Enable/Disable Input Voltage	V _{IL} of V _{CC} -1.475V _{DC} Maximum No Connection V _{IH} of V _{CC} -1.165V _{DC} Minimum	Enables Output Enables Output Disables Output: Logic Low Disables Complementary Output: Logic High
Start Up Time		10 mSeconds Maximum
RMS Phase Jitter	FJ = 12kHz to 20MHz	1 pSec Maximum

MANUFACTURER ECLIPTEK CORP.	CATEGORY OSCILLATOR	SERIES E11C2	PACKAGE CERAMIC	VOLTAGE 5.0V	CLASS 0566	REV. DATE 10/02
--------------------------------	------------------------	-----------------	--------------------	-----------------	---------------	--------------------

PART NUMBERING GUIDE

E11C2 F 2 C - 155.520M TR

FREQUENCY TOLERANCE & STABILITY/ OPERATING TEMPERATURE RANGE

C=±100ppm Maximum over 0°C to +70°C
 D=±50ppm Maximum over 0°C to +70°C
 E=±25ppm Maximum over 0°C to +70°C
 F=±20ppm Maximum over 0°C to +70°C
 G=±100ppm Maximum over -40°C to +85°C
 H=±50ppm Maximum over -40°C to +85°C

DUTY CYCLE

1=50% ±10%, 2=50% ±5%

AVAILABLE OPTIONS

Blank=Tubes
 TR=Tape and Reel (Standard)

FREQUENCY

LOGIC CONTROL/ADDITIONAL OUTPUT

A=No Connect
 B=Enable/Disable
 C=Complementary Output
 D=Complementary Output and Enable/Disable
 E=Complementary Output (Alt. Pin Configuration)
 G=Complementary Output and Enable/Disable (Alt. Pin Configuration)

MECHANICAL DIMENSIONS ALL DIMENSIONS IN MILLIMETERS

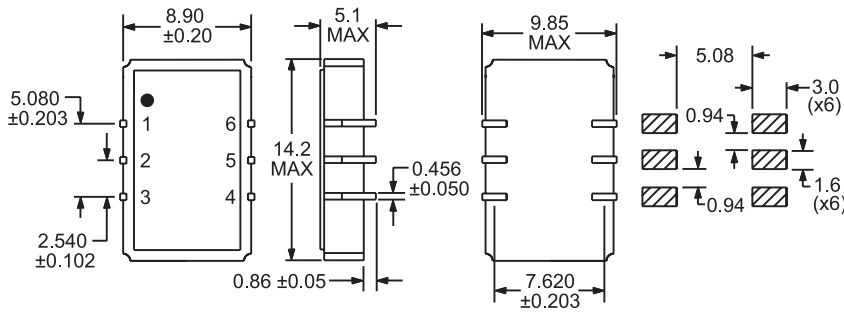

PIN CONNECTIONS TABLE

PIN	Logic Control/Additional Output Option					
	A	B	C	D	E	G
1	N/C	N/C	Q'	Q'	N/C	N/C
2	N/C	E/D	N/C	E/D	N/C	E/D
3	GND	GND	GND	GND	GND	GND
4	Q	Q	Q	Q	Q	Q
5	N/C	N/C	N/C	N/C	Q'	Q'
6	Vdd	Vdd	Vdd	Vdd	Vdd	Vdd

N/C = No Connect
 GND = Case Ground
 Q = Output
 Q' = Complementary Output
 E/D = Enable/Disable
 Vdd = Supply Voltage

TAPE AND REEL DIMENSIONS ALL DIMENSIONS IN MILLIMETERS

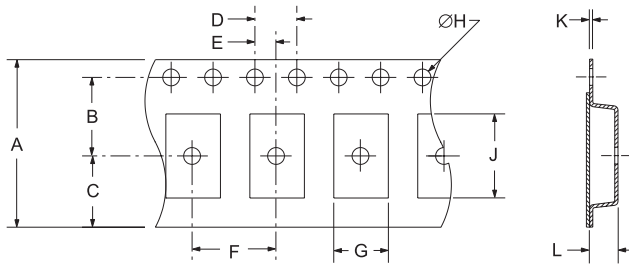

TAPE	A	B	C	D	E
	24 ±.3	11.5 ±.1	10.75 ±.1	4 ±.2	2 ±.1
F	G	H	J	K	L
12 ±.1	B0*	1.5 ±.1-0	A0*	.4 ±.05	K0*

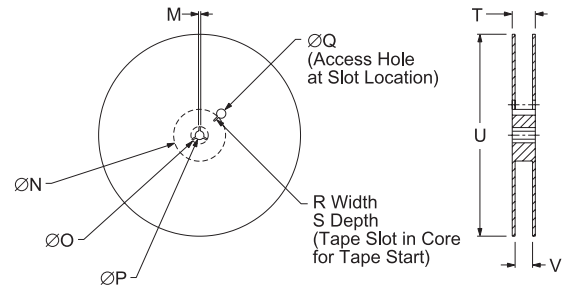

REEL	M	N	O	P	Q
	1.5 MIN	50 MIN	20.2 MIN	13 ±.2	40 MIN
R	S	T	U	V	QTY/REEL
2.5 MIN	10 MIN	30.4 MAX	360 MAX	24.4 ±2-0	1000

*Compliant to EIA 481A

ENVIRONMENTAL/MECHANICAL SPECIFICATIONS

Characteristic	Specification
Seal Integrity	Bubble test in Perfluorocarbon at +125°C ±5°C for 60 seconds minimum (internal crystal only).
Solderability	Sn63 Solder dip at +230°C ±5°C for 5 seconds/95% coverage.
Marking Permanency	10 Strokes with brush after 1 minute soak in solvent, 3 times.
Shock	Random drop on hard wooden plate 3 times from a height of 20cm.
Vibration	Frequency with an amplitude of 1.5mm sweeping between 10Hz to 55Hz within 1 minute (approximately) for 2 hours minimum on each axis (X, Y and Z) for a total of 6 hours.

MARKING SPECIFICATIONS

Line 1: ECLIPTEK
 Line 2: XX.XXX M
 ————— Frequency in MHz (5 Digits Maximum + Decimal)
 Line 3: XX Y ZZ
 ————— Week of Year
 ————— Last Digit of Year
 ————— Ecliptek Manufacturing Identifier

MANUFACTURER	CATEGORY	SERIES	PACKAGE	VOLTAGE	CLASS	REV. DATE
ECLIPTEK CORP.	OSCILLATOR	E11C2	CERAMIC	5.0V	OS66	10/02

E13C1 Series

- PECL Output Oscillators
- 3.3V supply voltage
- 4 pad ceramic SMD package with J-leads
- Stability to 20ppm
- Output Enable/Disable available
- Complementary Output available
- Available on Tape and Reel



NOTES

ELECTRICAL SPECIFICATIONS

Frequency Range		19.440MHz to 212.500MHz
Operating Temperature Range		0°C to 70°C or -40°C to 85°C
Storage Temperature Range		-55°C to 125°C
Supply Voltage (V_{CC})		3.3V _{DC} ±5%
Input Current		75mA Maximum
Logic Type		100KH
Frequency Tolerance / Stability	Inclusive of Operating Temp Range, Supply Voltage, Load, and Aging @25°C over 10 years	±100ppm, ±50ppm, ±25ppm, or ±20ppm Maximum
Output Voltage Logic High (V_{OH})		V _{CC} -1.025V _{DC} Minimum
Output Voltage Logic Low (V_{OL})		V _{CC} -1.620V _{DC} Maximum
Rise Time / Fall Time	20% to 80% of waveform	2 nSeconds Maximum
Duty Cycle	at 50% of waveform	50 ±10(%) 50 ±5(%)
Load Drive Capability		50 Ohms into V _{CC} -2.0V _{DC}
Logic Control / Additional Output		No Connect, Enable/Disable, or Complementary Output
Enable/Disable Input Voltage	V _{IL} of V _{CC} -1.475V _{DC} Maximum No Connection V _{IH} of V _{CC} -1.165V _{DC} Minimum	Enables Output Enables Output Disable Output: Logic Low Disables Complementary Output: Logic High
Start Up Time		10 mSeconds Maximum
RMS Phase Jitter	FJ = 12kHz to 20MHz	1 pSec Maximum

MANUFACTURER ECLIPTEK CORP.	CATEGORY OSCILLATOR	SERIES E13C1	PACKAGE CERAMIC	VOLTAGE 3.3V	CLASS 0563	REV. DATE 10/02
--------------------------------	------------------------	-----------------	--------------------	-----------------	---------------	--------------------

PART NUMBERING GUIDE

E13C1 F 2 C - 155.520M TR

FREQUENCY TOLERANCE & STABILITY/ OPERATING TEMPERATURE RANGE

C=±100ppm Maximum over 0°C to +70°C
 D=±50ppm Maximum over 0°C to +70°C
 E=±25ppm Maximum over 0°C to +70°C
 F=±20ppm Maximum over 0°C to +70°C
 G=±100ppm Maximum over -40°C to +85°C
 H=±50ppm Maximum over -40°C to +85°C

DUTY CYCLE

1=50% ±10%, 2=50% ±5%

AVAILABLE OPTIONS

Blank= Tubes
 TR= Tape and Reel (Standard)

FREQUENCY

LOGIC CONTROL/ADDITIONAL OUTPUT

A= No Connect
 B= Enable/Disable
 C= Complementary Output

MECHANICAL DIMENSIONS

ALL DIMENSIONS IN MILLIMETERS

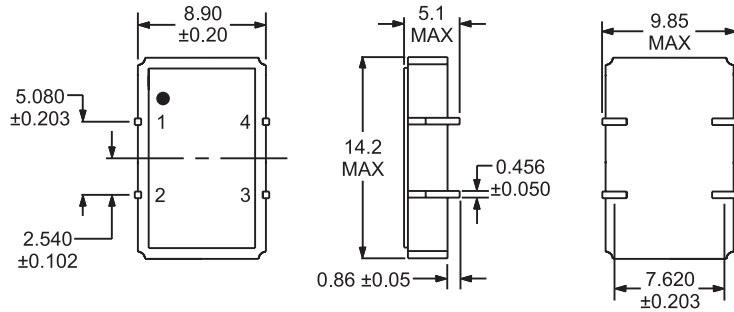

Pin 1: Complementary Output, No Connect, or Enable/Disable
 Pin 2: Case Ground Pin 3: Output Pin 4: Supply Voltage

SUGGESTED SOLDER PAD LAYOUT

ALL DIMENSIONS IN MILLIMETERS

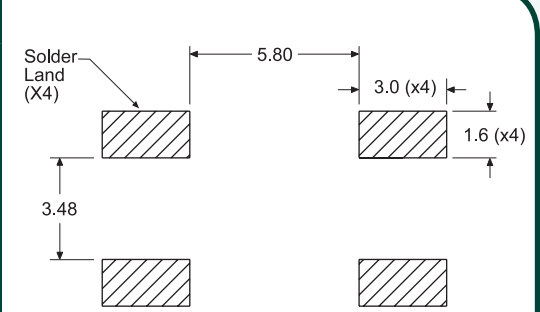

TAPE AND REEL DIMENSIONS

ALL DIMENSIONS IN MILLIMETERS

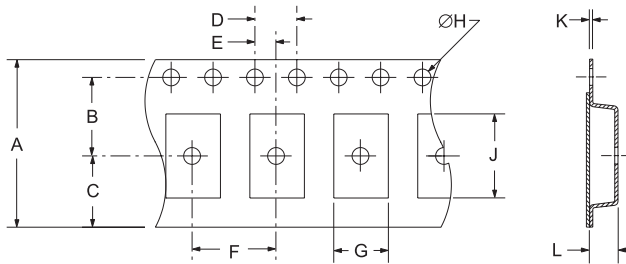

TAPE	A	B	C	D	E
	24 ±.3	11.5 ±.1	10.75 ±.1	4 ±.2	2 ±.1
F	G	H	J	K	L
	12 ±.1	B0*	1.5 ±.1-0	A0*	.4 ±.05

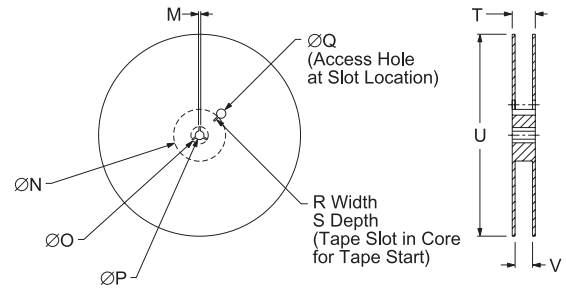

REEL	M	N	O	P	Q
	1.5 MIN	50 MIN	20.2 MIN	13 ±.2	40 MIN
R	S	T	U	V	QTY/REEL
	2.5 MIN	10 MIN	30.4 MAX	360 MAX	24.4+2-0

*Compliant to EIA 481A

ENVIRONMENTAL/MECHANICAL SPECIFICATIONS

Characteristic	Specification
Seal Integrity	Bubble test in Perfluorocarbon at +125°C ±5°C for 60 seconds minimum (internal crystal only).
Solderability	Sn63 Solder dip at +230°C ±5°C for 5 seconds/95% coverage.
Marking Permanency	10 Strokes with brush after 1 minute soak in solvent, 3 times.
Shock	Random drop on hard wooden plate 3 times from a height of 20cm.
Vibration	Frequency with an amplitude of 1.5mm sweeping between 10Hz to 55Hz within 1 minute (approximately) for 2 hours minimum on each axis (X, Y and Z) for a total of 6 hours.

MARKING SPECIFICATIONS

Line 1: ECLIPTEK
 Line 2: XX.XXX M
 — Frequency in MHz (5 Digits Maximum + Decimal)
 Line 3: XX Y ZZ
 — Week of Year
 — Last Digit of Year
 — Ecliptek Manufacturing Identifier

MANUFACTURER	CATEGORY	SERIES	PACKAGE	VOLTAGE	CLASS	REV. DATE
ECLIPTEK CORP.	OSCILLATOR	E13C1	CERAMIC	3.3V	OS63	10/02

E13C2 Series

- PECL Output Oscillators
- 3.3V supply voltage
- 6 pad ceramic SMD package with J-leads
- Stability to 20ppm
- Output Enable/Disable available
- Complementary Output available
- Available on Tape and Reel



NOTES

ELECTRICAL SPECIFICATIONS

Frequency Range	19.440MHz to 212.500MHz	
Operating Temperature Range	0°C to 70°C or -40°C to 85°C	
Storage Temperature Range	-55°C to 125°C	
Supply Voltage (V_{CC})	3.3V _{DC} ±5%	
Input Current	75mA Maximum	
Logic Type	100KH	
Frequency Tolerance / Stability	Inclusive of Operating Temp Range, Supply Voltage, Load, and Aging @25°C over 10 years	±100ppm, ±50ppm, ±25ppm, or ±20ppm Maximum
Output Voltage Logic High (V_{OH})	V _{CC} -1.025V _{DC} Minimum	
Output Voltage Logic Low (V_{OL})	V _{CC} -1.620V _{DC} Maximum	
Rise Time / Fall Time	20% to 80% of waveform	2 nSeconds Maximum
Duty Cycle	at 50% of waveform	50 ±10(%) 50 ±5(%)
Load Drive Capability	50 Ohms into V _{CC} -2.0V _{DC}	
Logic Control / Additional Output	No Connect, Enable/Disable, Complementary Output, or Complementary Output and Enable/Disable	
Enable/Disable Input Voltage	V _{IL} of V _{CC} -1.475V _{DC} Maximum No Connection V _{IH} of V _{CC} -1.165V _{DC} Minimum	Enables Output Enables Output Disables Output: Logic Low Disables Complementary Output: Logic High
Start Up Time	10 mSeconds Maximum	
RMS Phase Jitter	FJ = 12kHz to 20MHz	1 pSec Maximum

MANUFACTURER ECLIPTEK CORP.	CATEGORY OSCILLATOR	SERIES E13C2	PACKAGE CERAMIC	VOLTAGE 3.3V	CLASS 0564	REV. DATE 10/02
--------------------------------	------------------------	-----------------	--------------------	-----------------	---------------	--------------------

PART NUMBERING GUIDE

E13C2 F 2 C - 155.520M TR

FREQUENCY TOLERANCE & STABILITY/ OPERATING TEMPERATURE RANGE

C=±100ppm Maximum over 0°C to +70°C
 D=±50ppm Maximum over 0°C to +70°C
 E=±25ppm Maximum over 0°C to +70°C
 F=±20ppm Maximum over 0°C to +70°C
 G=±100ppm Maximum over -40°C to +85°C
 H=±50ppm Maximum over -40°C to +85°C

DUTY CYCLE

1=50% ±10%, 2=50% ±5%

AVAILABLE OPTIONS

Blank=Tubes
 TR=Tape and Reel (Standard)

FREQUENCY

LOGIC CONTROL/ADDITIONAL OUTPUT

A=No Connect
 B=Enable/Disable
 C=Complementary Output
 D=Complementary Output and Enable/Disable
 E=Complementary Output (Alt. Pin Configuration)
 G=Complementary Output and Enable/Disable (Alt. Pin Configuration)

MECHANICAL DIMENSIONS ALL DIMENSIONS IN MILLIMETERS

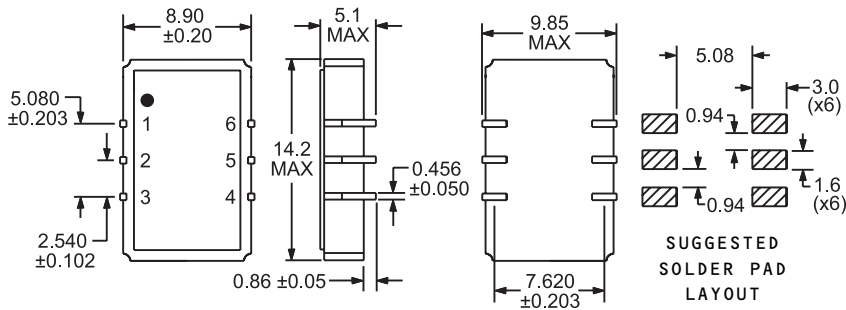

PIN CONNECTIONS TABLE

PIN	Logic Control/Additional Output Option					
	A	B	C	D	E	G
1	N/C	N/C	Q'	Q'	N/C	N/C
2	N/C	E/D	N/C	E/D	N/C	E/D
3	GND	GND	GND	GND	GND	GND
4	Q	Q	Q	Q	Q	Q
5	N/C	N/C	N/C	N/C	Q'	Q'
6	Vdd	Vdd	Vdd	Vdd	Vdd	Vdd

N/C = No Connect
 GND = Case Ground
 Q = Output
 Q' = Complementary Output
 E/D = Enable/Disable
 Vdd = Supply Voltage

TAPE AND REEL DIMENSIONS ALL DIMENSIONS IN MILLIMETERS

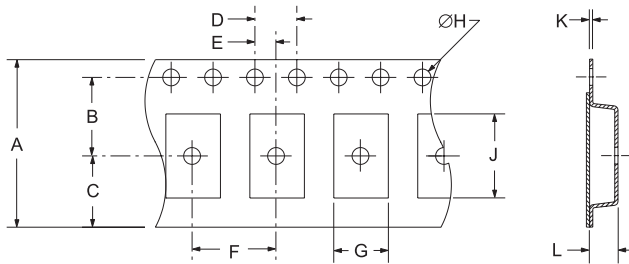

TAPE	A	B	C	D	E
	24 ±.3	11.5 ±.1	10.75 ±.1	4 ±.2	2 ±.1
F	G	H	J	K	L
12 ±.1	B0*	1.5 ±.1-0	A0*	.4 ±.05	K0*

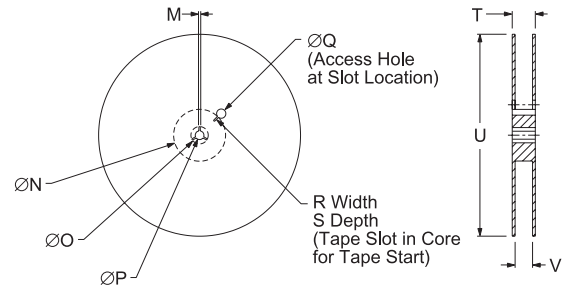

REEL	M	N	O	P	Q
	1.5 MIN	50 MIN	20.2 MIN	13 ±.2	40 MIN
R	S	T	U	V	QTY/REEL
2.5 MIN	10 MIN	30.4 MAX	360 MAX	24.4 ±2-0	1000

*Compliant to EIA 481A

ENVIRONMENTAL/MECHANICAL SPECIFICATIONS

Characteristic	Specification
Seal Integrity	Bubble test in Perfluorocarbon at +125°C ±5°C for 60 seconds minimum (internal crystal only).
Solderability	Sn63 Solder dip at +230°C ±5°C for 5 seconds/95% coverage.
Marking Permanency	10 Strokes with brush after 1 minute soak in solvent, 3 times.
Shock	Random drop on hard wooden plate 3 times from a height of 20cm.
Vibration	Frequency with an amplitude of 1.5mm sweeping between 10Hz to 55Hz within 1 minute (approximately) for 2 hours minimum on each axis (X, Y and Z) for a total of 6 hours.

MARKING SPECIFICATIONS

Line 1: ECLIPTEK
 Line 2: XX.XXX M
 ————— Frequency in MHz (5 Digits Maximum + Decimal)
 Line 3: XX Y ZZ
 ————— Week of Year
 ————— Last Digit of Year
 ————— Ecliptek Manufacturing Identifier

MANUFACTURER	CATEGORY	SERIES	PACKAGE	VOLTAGE	CLASS	REV. DATE
ECLIPTEK CORP.	OSCILLATOR	E13C2	CERAMIC	3.3V	OS64	10/02

E31C2 Series

- PECL Output VCXO
- 5.0V supply voltage
- 6 pad ceramic SMD package with J-leads
- Stability to 20ppm
- Output Enable/Disable available
- Complementary Output available
- Available on Tape and Reel

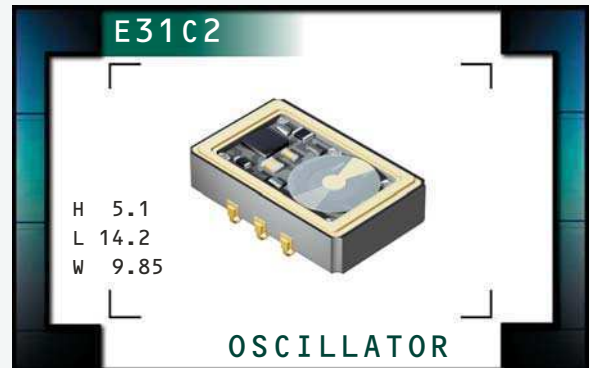

ELECTRICAL SPECIFICATIONS

Frequency Range		19.440MHz to 83.333MHz
Operating Temperature Range		0°C to 70°C or -40°C to 85°C
Storage Temperature Range		-55°C to 125°C
Supply Voltage (V_{CC})		5.0V _{DC} ±5%
Input Current		100mA Maximum
Logic Type		100KH
Frequency Tolerance / Stability	Inclusive of Operating Temp Range, Supply Voltage, Load, and Aging @25°C over 10 years	±50ppm, ±25ppm, or ±20ppm Maximum
Output Voltage Logic High (V_{OH})		V _{CC} -1.025V _{DC} Minimum
Output Voltage Logic Low (V_{OL})		V _{CC} -1.620V _{DC} Maximum
Rise Time / Fall Time	20% to 80% of waveform	2 nSeconds Maximum
Duty Cycle	at 50% of waveform	50 ±10(%) 50 ±5(%)
Load Drive Capability		50 Ohms into V _{CC} -2.0V _{DC}
Additional Output / Logic Control		No Connect and Single Output Enable/Disable and Single Output No Connect and Complementary Output or Enable/Disable and Complementary Output
Enable/Disable Input Voltage	V _{IL} of V _{CC} -1.475V _{DC} Maximum No Connection V _{IH} of V _{CC} -1.165V _{DC} Minimum	Enables Output Enables Output Disables Output: Logic Low Disables Complementary Output: Logic High
Start Up Time		10 mSeconds Maximum
RMS Phase Jitter	FJ = 12kHz to 20MHz	1 pSec Maximum
Absolute Pull Range (APR)	Inclusive of Operating Temp Range, Supply Voltage, Load, and Aging @25°C over 10 years	±50ppm Minimum
Linearity		20%, 15%, or 10% Maximum
Control Voltage (V_C): Test Conditions for APR		2.5V _{DC} ±2.0V _{DC}
Control Voltage Range (V_{CR})		0.0V _{DC} to V _{CC}
Center Control Voltage		2.5V _{DC}
Transfer Function		Positive Transfer Characteristic
Input Impedance		50kOhms Typical
Modulation Bandwidth	at -3dB with Control Voltage of +2.5V _{DC}	10kHz Minimum

MANUFACTURER ECLIPTEK CORP.	CATEGORY OSCILLATOR	SERIES E31C2	PACKAGE CERAMIC	VOLTAGE 5.0V	CLASS 0568	REV. DATE 10/02
--------------------------------	------------------------	-----------------	--------------------	-----------------	---------------	--------------------

PART NUMBERING GUIDE

E31C2 F3 A 2 C - 77.760M TR

FREQUENCY TOLERANCE & STABILITY/ OPERATING TEMPERATURE RANGE

D=±50ppm Maximum over 0°C to +70°C
 E=±25ppm Maximum over 0°C to +70°C
 F=±20ppm Maximum over 0°C to +70°C
 H=±50ppm Maximum over -40°C to +85°C

APR

3=±50ppm Minimum

LINEARITY

A=20%
 B=15%
 C=10%

AVAILABLE OPTIONS

Blank=Tubes
 TR = Tape and Reel (Standard)

FREQUENCY

ADDITIONAL OUTPUT/LOGIC CONTROL

A=No Connect and Single Output
 B=Enable/Disable and Single Output
 C=No Connect and Complementary Output
 D=Enable/Disable and Complementary Output

DUTY CYCLE

1=50 ±10(%), 2=50 ±5(%)

MECHANICAL DIMENSIONS ALL DIMENSIONS IN MILLIMETERS

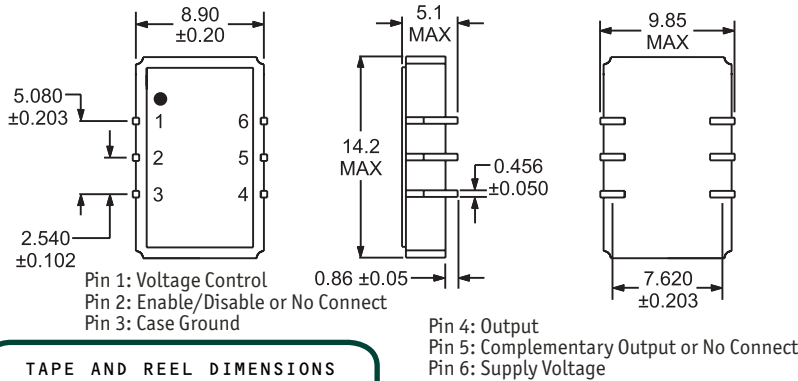

SUGGESTED SOLDER PAD LAYOUT ALL DIMENSIONS IN MILLIMETERS

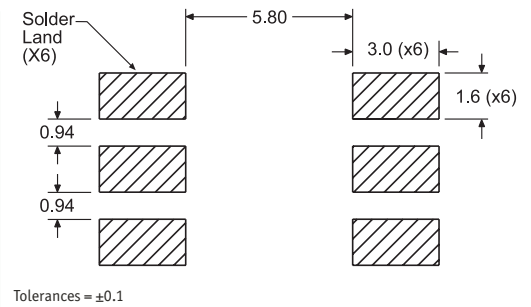

TAPE AND REEL DIMENSIONS ALL DIMENSIONS IN MILLIMETERS

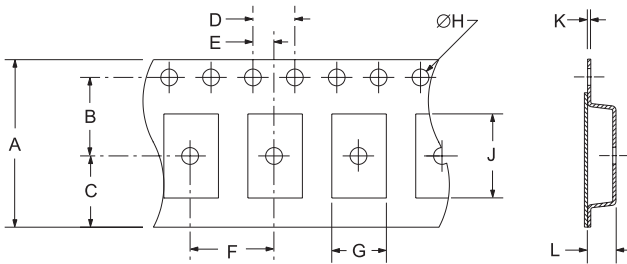

TAPE	A	B	C	D	E
	24±.3	11.5±.1	10.75±.1	4±.2	2±.1
F	G	H	J	K	L
	B0*	1.5±.1-0	A0*	.4±.05	K0*

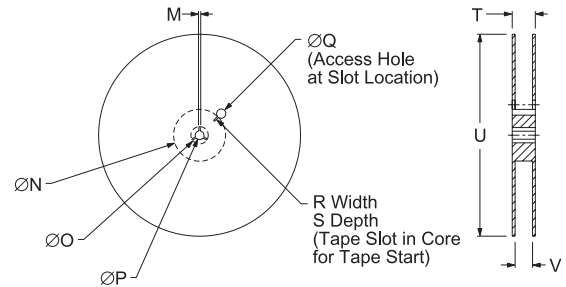

REEL	M	N	O	P	Q
	1.5 MIN	50 MIN	20.2 MIN	13±.2	40 MIN
R	S	T	U	V	QTY/REEL
	2.5 MIN	10 MIN	30.4 MAX	360 MAX	24.4±2-0

*Compliant to EIA 481A

ENVIRONMENTAL/MECHANICAL SPECIFICATIONS

Characteristic	Specification
Seal Integrity	Bubble test in Perfluorocarbon at +125°C ±5°C for 60 seconds minimum (internal crystal only).
Solderability	Sn63 Solder dip at +230°C ±5°C for 5 seconds/95% coverage.
Marking Permanency	10 Strokes with brush after 1 minute soak in solvent, 3 times.
Shock	Random drop on hard wooden plate 3 times from a height of 20cm.
Vibration	Frequency with an amplitude of 1.5mm sweeping between 10Hz to 55Hz within 1 minute (approximately) for 2 hours minimum on each axis (X, Y and Z) for a total of 6 hours.

MARKING SPECIFICATIONS

Line 1: ECLIPTEK
 Line 2: XX.XXX M
 — Frequency in MHz (5 Digits Maximum + Decimal)
 Line 3: XX Y ZZ
 — Week of Year
 — Last Digit of Year
 — Ecliptek Manufacturing Identifier

MANUFACTURER	CATEGORY	SERIES	PACKAGE	VOLTAGE	CLASS	REV. DATE
ECLIPTEK CORP.	OSCILLATOR	E31C2	CERAMIC	5.0V	OS68	10/02

E32C2 Series

- PECL Output VCXO
- 3.3V supply voltage
- 6 pad ceramic SMD package with J-leads
- Stability to 20ppm
- Output Enable/Disable available
- Complementary Output available
- Available on Tape and Reel

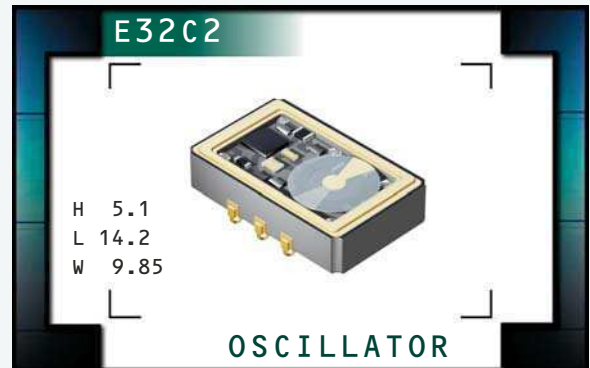

ELECTRICAL SPECIFICATIONS

Frequency Range		19.440MHz to 83.333MHz
Operating Temperature Range		0°C to 70°C or -40°C to 85°C
Storage Temperature Range		-55°C to 125°C
Supply Voltage (V_{CC})		3.3V _{DC} ±5%
Input Current		75mA Maximum
Logic Type		100KH
Frequency Tolerance / Stability	Inclusive of Operating Temp Range, Supply Voltage, Load, and Aging @25°C over 10 years	±50ppm, ±25ppm, or ±20ppm Maximum
Output Voltage Logic High (V_{OH})		V _{CC} -1.025V _{DC} Minimum
Output Voltage Logic Low (V_{OL})		V _{CC} -1.620V _{DC} Maximum
Rise Time / Fall Time	20% to 80% of waveform	2 nSeconds Maximum
Duty Cycle	at 50% of waveform	50 ±10(%) 50 ±5(%)
Load Drive Capability		50 Ohms into V _{CC} -2.0V _{DC}
Additional Output / Logic Control		No Connect and Single Output Enable/Disable and Single Output No Connect and Complementary Output or Enable/Disable and Complementary Output
Enable/Disable Input Voltage	V _{IL} of V _{CC} -1.475V _{DC} Maximum No Connection V _{IH} of V _{CC} -1.165V _{DC} Minimum	Enables Output Enables Output Disables Output: Logic Low Disables Complementary Output: Logic High
Start Up Time		10 mSeconds Maximum
RMS Phase Jitter	FJ = 12kHz to 20MHz	1 pSec Maximum
Absolute Pull Range (APR)	Inclusive of Operating Temp Range, Supply Voltage, Load, and Aging @25°C over 10 years	±50ppm Minimum
Linearity		20%, 15%, or 10% Maximum
Control Voltage (V_C): Test Conditions for APR		1.65V _{DC} ±1.35V _{DC}
Control Voltage Range (V_{CR})		0.0V _{DC} to V _{CC}
Center Control Voltage		1.65V _{DC}
Transfer Function		Positive Transfer Characteristic
Input Impedance		50kOhms Typical
Modulation Bandwidth	at -3dB with Control Voltage of +1.65V _{DC}	10kHz Minimum

MANUFACTURER ECLIPTEK CORP.	CATEGORY OSCILLATOR	SERIES E32C2	PACKAGE CERAMIC	VOLTAGE 3.3V	CLASS 0567	REV. DATE 10/02
--------------------------------	------------------------	-----------------	--------------------	-----------------	---------------	--------------------

PART NUMBERING GUIDE

E32C2 F3 A 2 C - 77.760M TR

FREQUENCY TOLERANCE & STABILITY/ OPERATING TEMPERATURE RANGE

D=±50ppm Maximum over 0°C to +70°C
 E=±25ppm Maximum over 0°C to +70°C
 F=±20ppm Maximum over 0°C to +70°C
 H=±50ppm Maximum over -40°C to +85°C

APR

3=±50ppm Minimum

LINEARITY

A=20%
 B=15%
 C=10%

AVAILABLE OPTIONS

Blank=Tubes
 TR = Tape and Reel (Standard)

FREQUENCY

ADDITIONAL OUTPUT/LOGIC CONTROL

A=No Connect and Single Output
 B=Enable/Disable and Single Output
 C=No Connect and Complementary Output
 D=Enable/Disable and Complementary Output

DUTY CYCLE

1=50 ±10(%), 2=50 ±5(%)

MECHANICAL DIMENSIONS ALL DIMENSIONS IN MILLIMETERS

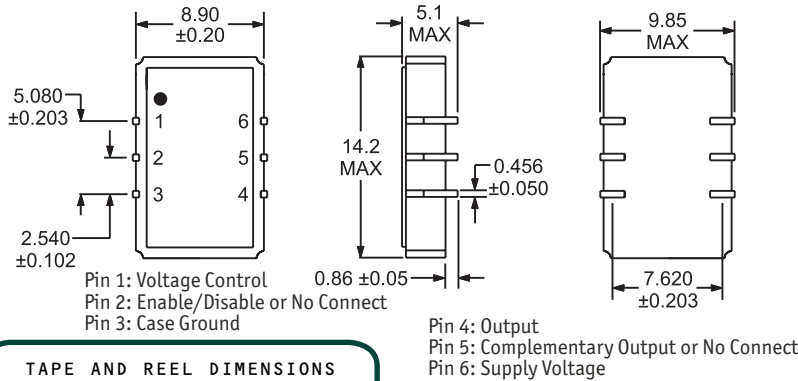

SUGGESTED SOLDER PAD LAYOUT ALL DIMENSIONS IN MILLIMETERS

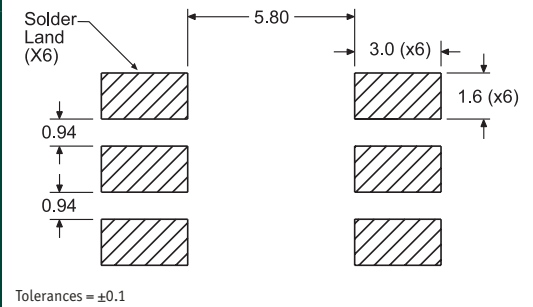

TAPE AND REEL DIMENSIONS ALL DIMENSIONS IN MILLIMETERS

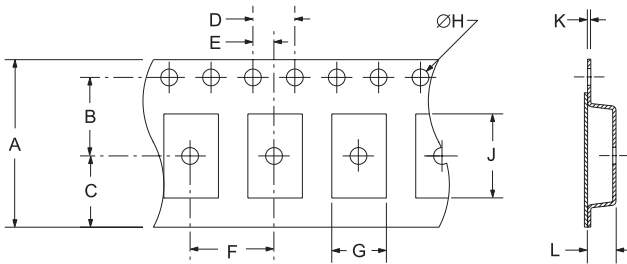

TAPE	A	B	C	D	E
	24±.3	11.5±.1	10.75±.1	4±.2	2±.1
F	G	H	J	K	L
	B0*	1.5±.1-0	A0*	.4±.05	K0*

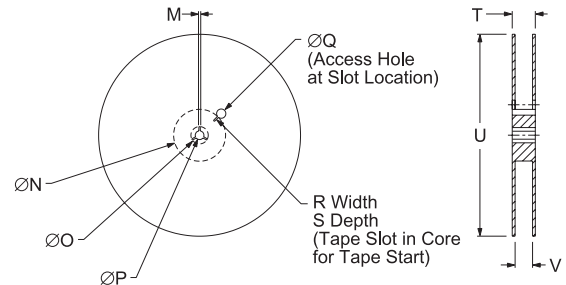

REEL	M	N	O	P	Q
	1.5 MIN	50 MIN	20.2 MIN	13±.2	40 MIN
R	S	T	U	V	QTY/REEL
	2.5 MIN	10 MIN	30.4 MAX	360 MAX	24.4±2-0

*Compliant to EIA 481A

ENVIRONMENTAL/MECHANICAL SPECIFICATIONS

Characteristic	Specification
Seal Integrity	Bubble test in Perfluorocarbon at +125°C ±5°C for 60 seconds minimum (internal crystal only).
Solderability	Sn63 Solder dip at +230°C ±5°C for 5 seconds/95% coverage.
Marking Permanency	10 Strokes with brush after 1 minute soak in solvent, 3 times.
Shock	Random drop on hard wooden plate 3 times from a height of 20cm.
Vibration	Frequency with an amplitude of 1.5mm sweeping between 10Hz to 55Hz within 1 minute (approximately) for 2 hours minimum on each axis (X, Y and Z) for a total of 6 hours.

MARKING SPECIFICATIONS

Line 1: ECLIPTEK
 Line 2: XX.XXX M
 — Frequency in MHz (5 Digits Maximum + Decimal)
 Line 3: XX Y ZZ
 — Week of Year
 — Last Digit of Year
 — Ecliptek Manufacturing Identifier

MANUFACTURER	CATEGORY	SERIES	PACKAGE	VOLTAGE	CLASS	REV. DATE
ECLIPTEK CORP.	OSCILLATOR	E32C2	CERAMIC	3.3V	OS67	10/02