

CONFORMAL COATED AXIAL INDUCTOR

CC1026 Series

Part Numbering Guide

*Standard	BODY STYLE Conformal Coated Axial	CC 1026 - 47 J - T&R	PACKAGING Blank=Bulk *T&R=Tape and Reel (pg. 001)
	BODY SIZE 2.8mm x 7.1mm (0.110" x 0.280")	VALUE in uH	TOLERANCE M=+/-20% K=+/-10% J=+/-5%

Standard Specifications

Dielectric Strength (Sea Level)	1000 Volts RMS
Operating Temperature Range	-20°C to +85°C
Construction	Conformal Coated

Ordering Information

Ecliptek Part Number	L (uH)	Q (Min)	Test Freq (MHz)	SRF Min. (MHz)	DCR Max. (ohms)	Rated DC Curr. (mA)	Ecliptek Part Number	L (uH)	Q (Min)	Test Freq (MHz)	SRF Min. (MHz)	DCR Max. (ohms)	Rated DC Curr. (mA)
CC1026-.22K	0.22	35	25.2	150	0.40	400	CC1026-15K	15	50	2.52	17	2.8	145
CC1026-.27K	0.27	35	25.2	150	0.43	380	CC1026-18K	18	50	2.52	13	3.1	140
CC1026-.33K	0.33	35	25.2	150	0.48	370	CC1026-22K	22	50	2.52	9.6	3.4	130
CC1026-.39K	0.39	35	25.2	150	0.51	350	CC1026-27K	27	50	2.52	7.2	3.8	125
CC1026-.47K	0.47	40	25.2	150	0.56	330	CC1026-33K	33	50	2.52	6.3	4.1	120
CC1026-.56K	0.56	40	25.2	150	0.61	320	CC1026-39K	39	50	2.52	6.3	4.5	115
CC1026-.68K	0.68	40	25.2	150	0.67	310	CC1026-47K	47	50	2.52	6.3	4.9	110
CC1026-.82K	0.82	40	25.2	150	0.74	290	CC1026-56K	56	50	2.52	6.2	5.3	105
CC1026-1.0K	1.0	50	25.2	150	0.80	270	CC1026-68K	68	50	2.52	5.7	5.8	100
CC1026-1.2K	1.2	50	7.96	144	0.90	260	CC1026-82K	82	50	2.52	5.3	6.3	95
CC1026-1.5K	1.5	50	7.96	131	1.0	250	CC1026-100K	100	50	2.52	4.8	7.0	90
CC1026-1.8K	1.8	50	7.96	121	1.1	240	CC1026-120K	120	50	0.796	3.8	13.0	90
CC1026-2.2K	2.2	50	7.96	110	1.2	230	CC1026-150K	150	50	0.796	3.5	15.0	85
CC1026-2.7K	2.7	50	7.96	100	1.3	220	CC1026-180K	180	50	0.796	3.3	16.0	80
CC1026-3.3K	3.3	50	7.96	94	1.4	210	CC1026-220K	220	50	0.796	3.0	17.0	75
CC1026-3.9K	3.9	50	7.96	65	1.6	200	CC1026-270K	270	50	0.796	2.8	19.0	65
CC1026-4.7K	4.7	50	7.96	56	1.7	190	CC1026-330K	330	50	0.796	2.6	20.0	60
CC1026-5.6K	5.6	50	7.96	48	1.9	180	CC1026-390K	390	50	0.796	2.4	22.0	55
CC1026-6.8K	6.8	59	7.96	37	2.0	175	CC1026-470K	470	50	0.796	2.25	24.0	55
CC1026-8.2K	8.2	50	7.96	25	2.2	165	CC1026-560K	560	50	0.796	2.10	25.0	50
CC1026-10K	10	50	7.96	21	2.5	160	CC1026-680K	680	50	0.796	1.95	28.0	45
CC1026-12K	12	50	2.52	19	2.5	150	CC1026-820K	820	50	0.796	1.85	30.0	40
							CC1026-1000K	1000	50	0.796	1.40	33.0	40

Dimensions in Millimeters

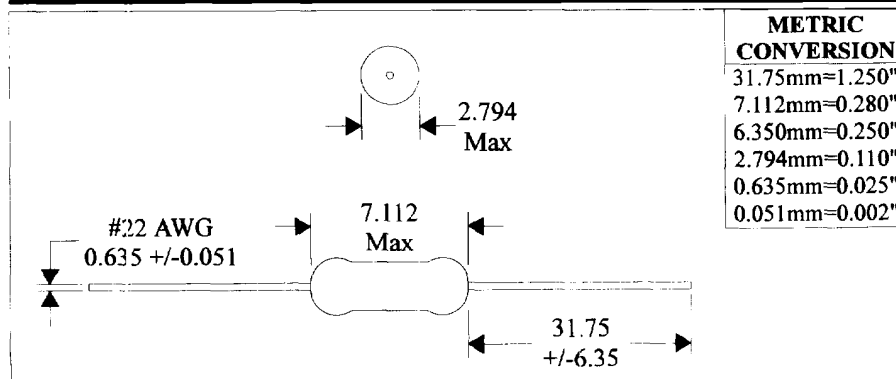

3545 CADILLAC AVENUE
COSTA MESA, CA 92626-1401
Phone: 714-433-1200
Fax: 714-433-1234
Specifications Subject To Change Without Notice.
Contact Factory For Latest Revision or use
Fax-On-Demand: 1-800-ECLIPTEK
Internet: <http://www.ecliptek.com/ecliptek/>
Email: ecliptek-sales@ecliptek.com



ECLIPTEK
CORPORATION