

Visible Beam Allows Visual Confirmation of the Detection Spot, for Easy Installation and Maintenance

- Built-in amplifier
- Mutual interference protection filter included in product offering
- Long sensing distance: 10 M
- Prewired or connector models
- Light-ON/Dark-ON switch-selectable
- Noise Immunity due to IC chip design
- IP67, CE approved



Ordering Information

■ Standard Models

Sensing method	Appearance	Connection method	Sensing distance	Part number	
				NPN output	PNP output
Through-beam		Prewired (2 m)		E3Z-T61A	E3Z-T81A
		Connector		E3Z-T66A	E3Z-T86A

■ Accessories (Order Separately)

Slit

Slit width	Sensing distance (typical)	Minimum sensing target (typical)	Quantity	Part number
0.5 mm dia.	35 mm	0.2 mm dia.	One for the emitter and one for the receiver	E39-S65A
1 mm dia.	150 mm	0.4 mm dia.		E39-S65B
2 mm dia.	550 mm	0.7 mm dia.		E39-S65C
0.5×10 mm	700 mm	0.2 mm dia.		E39-S65D
1×10 mm	1.5 m	0.5 mm dia.		E39-S65E
2×10 mm	3.5 m	0.8 mm dia.		E39-S65F

Mutual Interference Protection Filter

Sensing distance	Dimensions	Comments	Quantity	Part number
3 m		The arrow indicates the direction of polarized light. Mutual interference can be prevented by altering the direction of polarized light from or to adjacent emitters and receivers.	Two filters for the emitter and two for the receiver (total of four)	E39-E11

■ Brackets (All E3Z Models Use Common Brackets)

To order, you'll find the appropriate brackets for the E3Z-TA when you refer to the basic E3Z Photoelectric Sensor data sheet on Omron's web site @ www.omron.com/oei, or refer to the Sensing Products Catalog.

■ M8 Connectors (All E3Z Models Use Common Connectors)

To order M8 Connectors, see the basic E3Z Photoelectric Sensor data sheet on Omron's web site @ www.omron.com/oei, or refer to the Sensing Products Catalog.

Specifications

■ Ratings/Characteristics

Item	Sensing method	Through-beam
	NPN output	E3Z-T61A/T66A
	PNP output	E3Z-T81A/T86A
Sensing distance	10 m	
Standard sensing target	Opaque: 12-mm dia. min.	
Directional angle	Both emitter and receiver: 3° to 5°	
Light source (wave length)	Red LED (700 nm)	
Power supply voltage	12 to 24 VDC \pm 10%	
Current consumption	Emitter: 15 mA Receiver: 20 mA	
Control output	Load power supply voltage: 26.4 VDC max. Load current: 100 mA max. (Residual voltage: 1 V max.) Open collector output (NPN or PNP depending on model) L-ON/D-ON switch-selectable	
Circuit protection	Protection from load short-circuit and reversed power supply connection	
Response time	Operation or reset: 1 ms max.	
Sensitivity adjustment	One-turn potentiometer	
Ambient illumination (receiver side)	Incandescent lamp: 3,000 lux max. Sunlight: 10,000 lux max.	
Ambient temperature	Operating: -25°C to 55°C (-13°F to 131°F) Storage: -40°C to 70°C (-40°F to 158°F) with no icing or condensation	
Ambient humidity	Operating: 35% to 85%/Storage: 35% to 95% (with no condensation)	
Insulation resistance	20 M Ω min. at 500 VDC	
Dielectric strength	1,000 VAC, 50/60 Hz for 1 min	
Vibration resistance	10 to 55 Hz, 1.5-mm double amplitude or 300 m/s ² for 2 hours each in X, Y, and Z directions	
Shock resistance	500 m/s ² 3 times each in X, Y, and Z directions	
Degree of protection	IP67 (IEC60529)	
Connection method	Prewired cable (standard length: 2 m) or M8 connector model	
Indicator	Operation indicator (orange) Stability indicator (green) Emitter has power indicator (orange) only.	
Weight (packed state)	Prewired cable (2 m)	Approx. 120 g (4.23 oz.)
	Connector	Approx. 30 g (1.06 oz.)
Material	Case	PBT (polybutylene terephthalate)
	Lens	Methacrylate resin
Accessories	Instruction manual	

Engineering Data

■ Parallel Operating Range (Typical)

E3Z-T□A

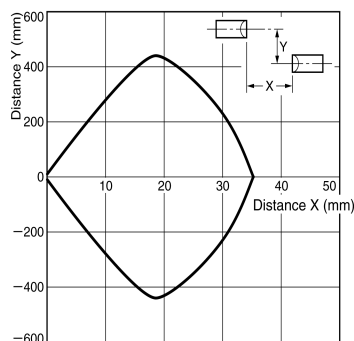

■ Receiver Output vs. Distance (Typical)

E3Z-T□A

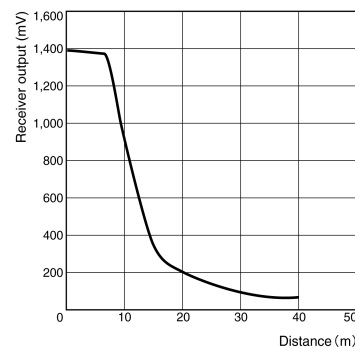

Operation

■ NPN Output

Model	E3Z-T61A/E3Z-T66A	
Output transistor status	Light ON	Dark ON
Timing chart	<p>Incident Interrupted</p> <p>Operation indicator (orange) ON OFF</p> <p>Output transistor ON OFF</p> <p>Load (relay) Operate Reset</p>	<p>Incident Interrupted</p> <p>Operation indicator (orange) ON OFF</p> <p>Output transistor ON OFF</p> <p>Load (relay) Operate Reset</p>
Mode selector	Light ON (L/ON)	Dark ON (D/ON)
Output circuit	<p>Through-beam receiver</p> <p>Operation indicator (Orange), Stability indicator (Green)</p> <p>Main circuit, Control output</p> <p>12 to 24 VDC, 100 mA, Black max., Load (Relay)</p> <p>0 V</p> <p>Connector Pin Arrangement</p>	

■ PNP Output

Model	E3Z-T81A/T86A	
Output transistor status	Light ON	Dark ON
Timing chart	<p>Incident Interrupted</p> <p>Operation indicator (orange) ON OFF</p> <p>Output transistor ON OFF</p> <p>Load (relay) Operate Reset</p>	<p>Incident Interrupted</p> <p>Operation indicator (orange) ON OFF</p> <p>Output transistor ON OFF</p> <p>Load (relay) Operate Reset</p>
Mode selector	Light ON (L/ON)	Dark ON (D/ON)
Output circuit	<p>Through-beam receiver</p> <p>Operation indicator (Orange), Stability indicator (Green)</p> <p>Main circuit, Control output</p> <p>12 to 24 VDC, 100 mA max., Load (Relay)</p> <p>0 V</p> <p>Connector Pin Arrangement</p> <p>Pin 2 is open.</p>	

Structure of Sensor I/O Connector

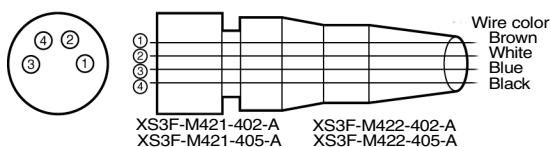

Classification	Wire color	Connector pin No.	Use
DC	Brown	1	Power supply (+V)
	White	2	Pin 2 is not used.
	Blue	3	Power supply (0 V)
	Black	4	Output

Dimensions

Unit: mm (inch)

■ Sensors

Prewired Through-beam Models

E3Z-T61A
E3Z-T81A

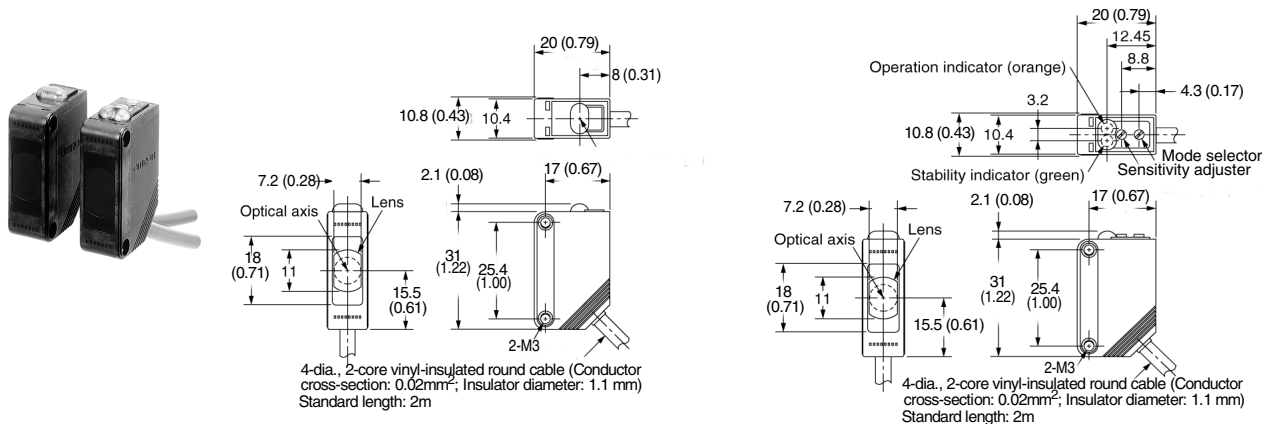

Through-beam Models with Connector

E3Z-T66A
E3Z-T86A

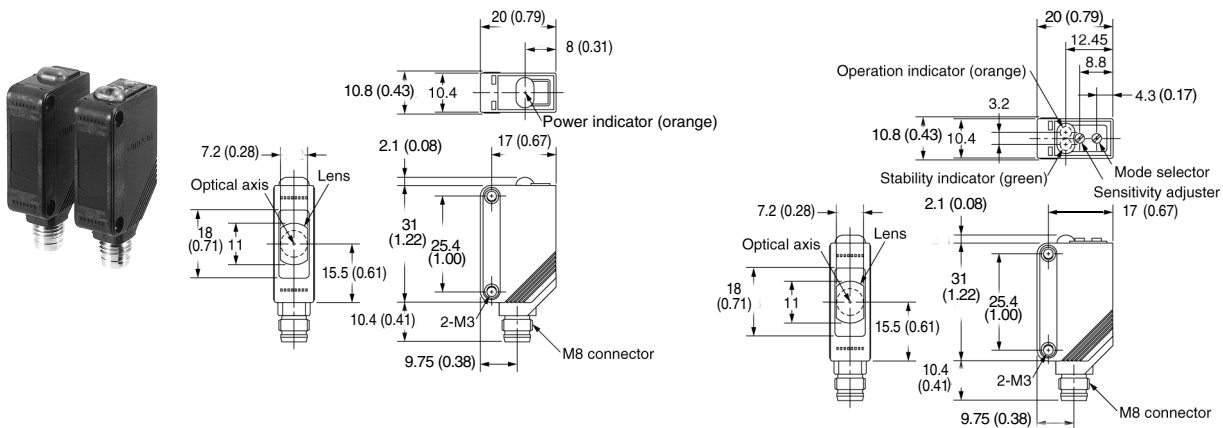

■ Accessories

Brackets, M8 Connectors, and Slits

For dimensions of Brackets, M8 Connectors, or Slits, see the Dimensions Section in the basic E3Z Photoelectric Sensor data sheet on Omron's web site @ www.omron.com/oei, or refer to the E3Z in Omron's Sensing Products Catalog.

Precautions

To ensure safe sensor operation, please follow these precautions.

■ Wiring

Power Supply Voltage

Make sure that the power supply to the Sensor is within the rated voltage range.

Load Short-Circuiting

Do not short-circuit the load, or the Sensor may be damaged.

Polarity

Correct polarity wiring is required to prevent damage to the sensor.

Connection without Load

Do not connect the power supply to the Sensor when no load is connected, or the internal elements may explode or burn.

■ Operating Environment

Do not use the Sensor in locations with explosive or flammable gas.

■ Settings

Power Reset Time

When the E3Z-TA is turned ON, there is a 100 ms delay time before operation. If the load and the Sensor are connected to independent power supplies, be sure to turn ON the sensor *before* turning ON the load.

■ Connections

M8 Metal Connector

- Turn OFF the power before disconnecting the sensor.
- Remove the connector cover before connecting or disconnecting the metal connector.
- Secure the connector cover by hand. Do not use pliers, or the connector may be damaged.
- The proper tightening torque range is between 0.3 and 0.4 N·m.

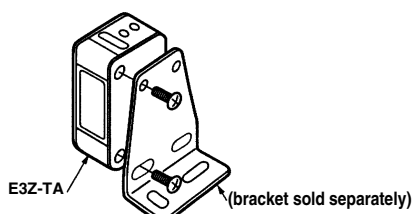

■ Mounting and Adjusting Slits

- Hook the upper protruding portion of the Slit to the upper indented mounting portion of the Sensor and adjust the position of the Slit so that the Slit will be parallel to the lens side of the Sensor. (See area 1, in the illustration below.)
- Then, press the lower protruding portion of the Slit onto the indented mounting portion of the Sensor until the Slit snaps in. (See area 2, shown below.)

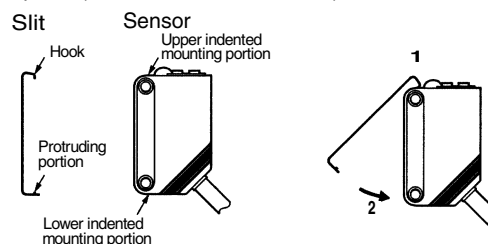

- Mounting views

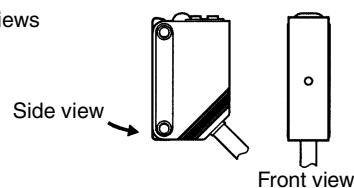

Removal Method

- Press the upper portion of the Slit. (See area 1, shown below.)
- Then, disconnect the lower protruding portion of the Slit from the Sensor and remove the Slit. (See area 2, shown below.)

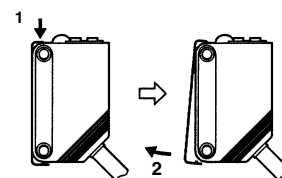

ALL DIMENSIONS SHOWN ARE IN MILLIMETERS.

To convert millimeters into inches, multiply by 0.03937. To convert grams into ounces, multiply by 0.03527.

OMRON

OMRON ELECTRONICS LLC

One East Commerce Drive
Schaumburg, IL 60173

1-800-55-OMRON

OMRON ON-LINE

Global - <http://www.omron.com>
USA - <http://www.omron.com/oei>
Canada - <http://www.omron.com/oci>

OMRON CANADA, INC.

885 Milner Avenue
Scarborough, Ontario M1B 5V8

416-286-6465