

## Applicable to a Wide Range of Pipe Diameters.



## Capacitive Sensors unaffected by liquid color.

- Mount to bypass pipes.
- Fit a wide range of pipe diameters: 8 to 11 mm or 12 to 26 mm
- Built-in Amplifiers to save space.



 Be sure to read *Safety Precautions* on page 3.

## Ordering Information

Sensing method	Applicable pipe diameters	Appearance	Output configuration/Operation mode		Model
Capacitive	8 to 11 mm		NPN open-collector output	NO	<b>E2K-L13MC1 2M</b>
	12 to 26 mm				<b>E2K-L26MC1 2M</b>

## Ratings and Specifications

Item	Model	E2K-L13MC1	E2K-L26MC1	
Applicable pipes	Materials	Non-metal		
	Size	Diameter	8 to 11 mm	12 to 26 mm
		Thickness	1 mm max.	1.5 mm max.
Detectable object		Liquid *		
Repeat accuracy		±0.2 mm max.		
Differential travel (Reference value, varies with pipe size and liquid.)		0.6 to 5 mm	0.3 to 3 mm	
Power supply voltage (operating voltage range)		12 to 24 VDC (10.8 to 30 VDC), ripple (p-p): 10% max.		
Current consumption		12 mA max.		
Control output	Load current	100 mA max.		
	Residual voltage	1 V max. (Load current: 100 mA, Cable length: 2 m)		
Sensing liquid position		Indented mark position (For details, refer to <i>Technical Guide (Operational version)</i> .)		
Indicators		Detection indicator (orange)		
Ambient temperature range		Operating: 0 to 55°C (with no icing or condensation), Storage: -10 to 65°C (with no icing or condensation)		
Ambient humidity range		Operating/Storage: 25% to 85% (with no condensation)		
Temperature influence		±4 mm of detection level at 23°C in the temperature range of 0 to 55°C (with pure water or 20% saline solution) (±6 mm for E2K-L13MC1 with pure water and a pipe diameter of 8 mm)		
Voltage influence		±0.5 mm of detection level at the rated voltage in rated voltage ±10% range		
Insulation resistance		50 MΩ min. (at 500 VDC) between current-carrying parts and case		
Dielectric strength		500 VAC, 50/60 Hz for 1 min between current-carrying parts and case		
Vibration resistance		Destruction: 10 to 55 Hz, 1.5-mm double amplitude for 2 hours each in X, Y, and Z directions		
Shock resistance		Destruction: 500 m/s <sup>2</sup> 3 times each in X, Y, and Z directions		
Degree of protection		IP66 (IEC)		
Connection method		Pre-wired Models (Standard cable length: 2 m)		
Weight (packed state)		Approx. 70 g		
Materials	Case, Cover	Heat-resistant ABS		
	Cable clamp	NBR		
Accessories		Two bands, Four slip-proof tubes, Instruction manual		

\* Stable detection will not be possible in the following cases. Confirm detection capability with the Sensor installed before actual application.

1. If the specific inductive capacity or the specific electric conductivity of the liquid is too low, the liquid position may not be detected since this sensor is a capacitive sensor.
2. If the quantity of liquid is too low or the change in quantity is too low in comparison to the change in liquid level because the pipe is too thin or the walls of the pipe are too thick
3. If there is a viscous film on the inner pipe wall, large quantities of foam or air bubbles, or excessive buildup of dirt on the inner pipe wall

## Engineering Data (Typical)

### Influence of Temperature and Sensing Liquid Level

E2K-L13MC1

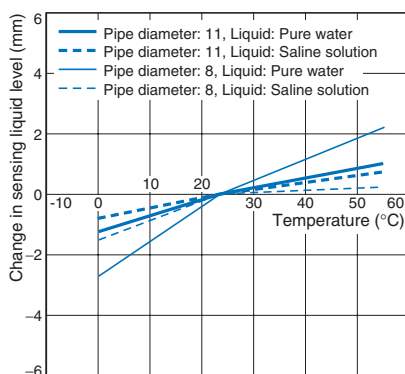

E2K-L26MC1

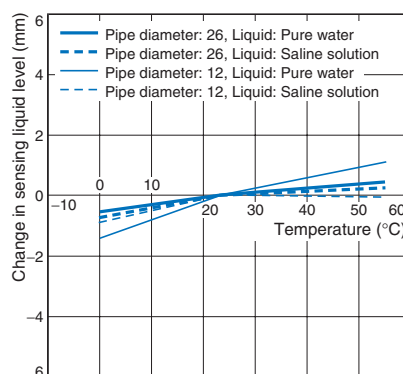

## I/O Circuit Diagrams

Operation mode	Model	Timing chart	Output circuit
NO	E2K-L13MC1 E2K-L26MC1	<p>Liquid level</p> <p>Present </p> <p>None </p> <p>Load (between brown and black leads)</p> <p>Operate </p> <p>Reset </p> <p>Detection indicator (orange)</p> <p>ON </p> <p>OFF </p>	<p>* Load current: 100 mA max.</p>

## Safety Precautions

Refer to *Warranty and Limitations of Liability*.

### ⚠ WARNING

This product is not designed or rated for ensuring safety of persons either directly or indirectly. Do not use it for such purposes.



### Precautions for Correct Use

Do not use this product under ambient conditions that exceed the ratings.

#### ● Design

#### Influence of Surrounding Objects

When mounting the Sensor, maintain at least the distances in the following diagrams from surrounding metal objects or other conductors to prevent the Sensor from being affected by objects other than the sensing object.

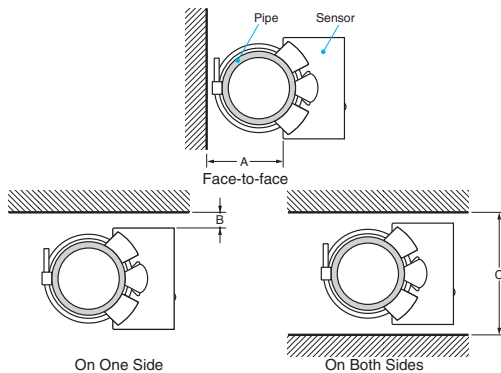

#### Influence of Surrounding Objects (Unit: mm)

Model	Distance	A	B	C
E2K-L13MC1	25	5	45	
E2K-L26MC1		0	40	

#### Mutual Interference

When installing Sensors in series, in parallel, or face-to-face, ensure that the minimum distances given in the following table are maintained.

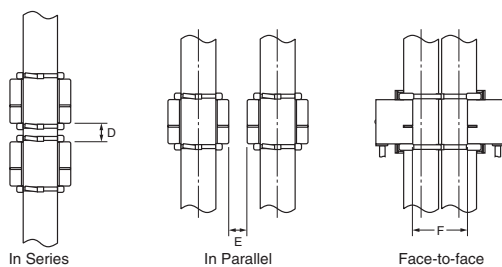

#### Mutual Interference

(Unit: mm)

Model	Distance	D *	E	F
E2K-L13MC1	10	10	10	25
E2K-L26MC1				30

\* Also, always adjust the bottom Sensor first because adjusting the bottom Sensor may affect the detection level of the top Sensor.

#### ● Mounting

#### Mounting

Mount the Sensor securely to the pipe using the enclosed two bands and four slip-proof tubes (two tubes used for each band) as shown in the following diagram.

When mounting the Sensor, be sure the entire Sensor is tight against the pipe along the sensing surface.

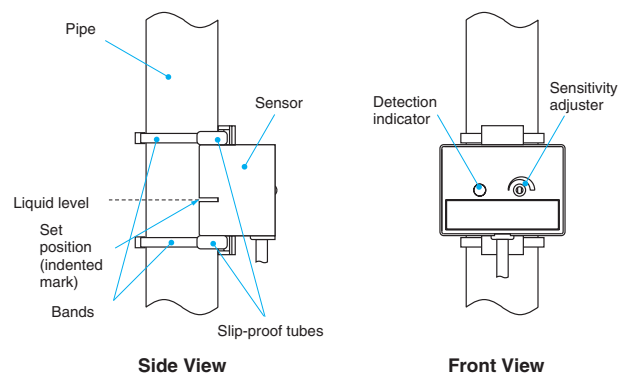

Side View

Front View

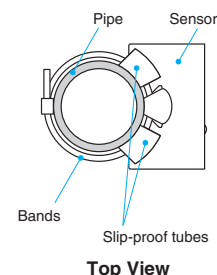

Top View

## ● Wiring

### Power Supply

- If the load and Sensor are connected to different power supplies, always turn ON the Sensor power first.
- Switching noise can cause operating mistakes if a commercial switching regulator is used. When using a switching regulator, always ground the frame ground terminal and the ground terminal.

## ● Operating Environment

### Ambient Atmosphere

- Although the Sensor is water resistance, it is a capacitive sensor and should not be used where it will come into direct contact with liquids, such as water or cutting oil.
- The life of the Sensor will be shortened by rapid changes in temperature even within the ambient operating temperature range. Do not use the Sensor in locations subject to rapid temperature changes.

## ● Miscellaneous

Drift will occur when the power supply is turned ON. If the specific inductive capacity of the sensing liquid is low, the detection level may increase by 2 to 3 mm during the 20 minutes required from the time the power supply is turned ON until operation stabilizes.

## Dimensions

(Unit: mm)

Tolerance class IT16 applies to dimensions in this data sheet unless otherwise specified.

### E2K-L13MC1

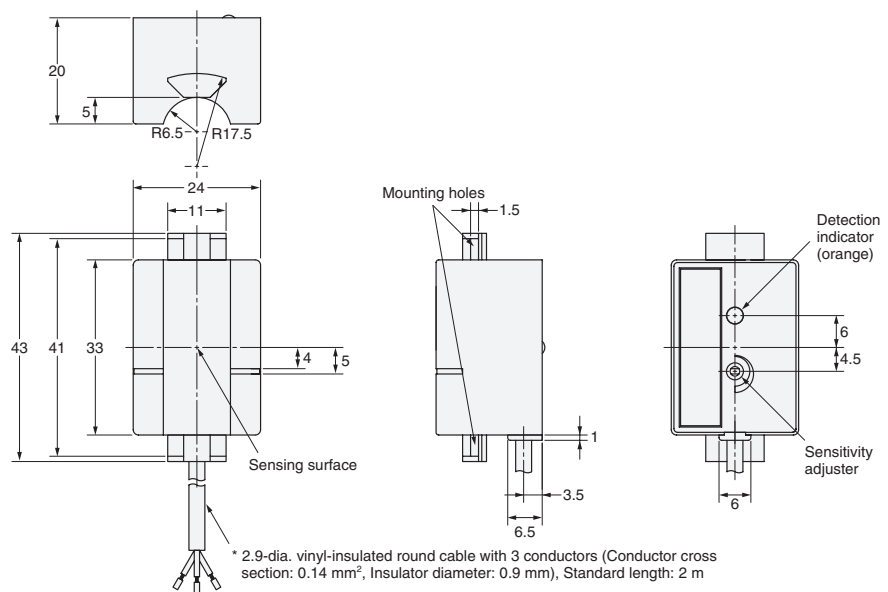

### E2K-L26MC1

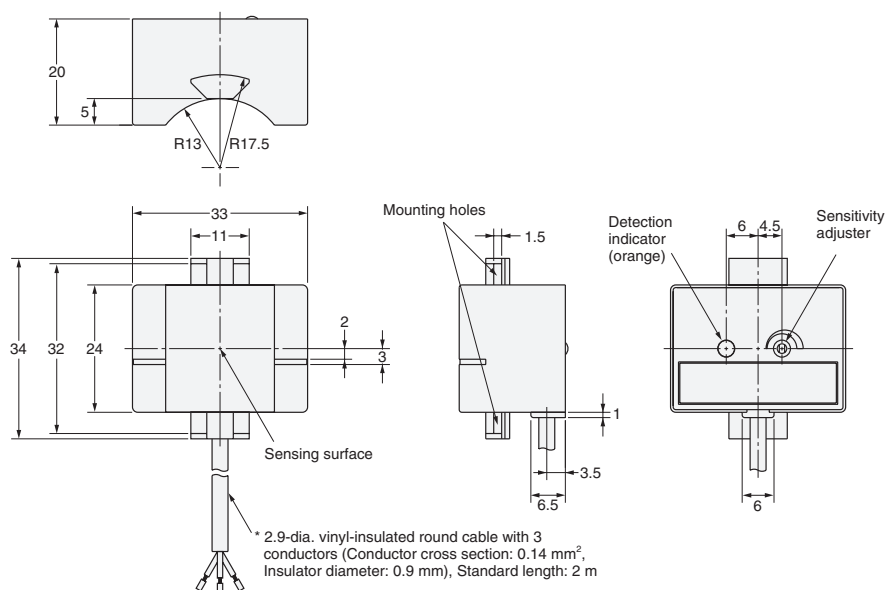

## Read and Understand This Catalog

Please read and understand this catalog before purchasing the products. Please consult your OMRON representative if you have any questions or comments.

## Warranty and Limitations of Liability

### WARRANTY

OMRON's exclusive warranty is that the products are free from defects in materials and workmanship for a period of one year (or other period if specified) from date of sale by OMRON.

OMRON MAKES NO WARRANTY OR REPRESENTATION, EXPRESS OR IMPLIED, REGARDING NON-INFRINGEMENT, MERCHANTABILITY, OR FITNESS FOR PARTICULAR PURPOSE OF THE PRODUCTS. ANY BUYER OR USER ACKNOWLEDGES THAT THE BUYER OR USER ALONE HAS DETERMINED THAT THE PRODUCTS WILL SUITABLY MEET THE REQUIREMENTS OF THEIR INTENDED USE. OMRON DISCLAIMS ALL OTHER WARRANTIES, EXPRESS OR IMPLIED.

### LIMITATIONS OF LIABILITY

OMRON SHALL NOT BE RESPONSIBLE FOR SPECIAL, INDIRECT, OR CONSEQUENTIAL DAMAGES, LOSS OF PROFITS OR COMMERCIAL LOSS IN ANY WAY CONNECTED WITH THE PRODUCTS, WHETHER SUCH CLAIM IS BASED ON CONTRACT, WARRANTY, NEGLIGENCE, OR STRICT LIABILITY.

In no event shall the responsibility of OMRON for any act exceed the individual price of the product on which liability is asserted.

IN NO EVENT SHALL OMRON BE RESPONSIBLE FOR WARRANTY, REPAIR, OR OTHER CLAIMS REGARDING THE PRODUCTS UNLESS OMRON'S ANALYSIS CONFIRMS THAT THE PRODUCTS WERE PROPERLY HANDLED, STORED, INSTALLED, AND MAINTAINED AND NOT SUBJECT TO CONTAMINATION, ABUSE, MISUSE, OR INAPPROPRIATE MODIFICATION OR REPAIR.

## Application Considerations

### SUITABILITY FOR USE

OMRON shall not be responsible for conformity with any standards, codes, or regulations that apply to the combination of products in the customer's application or use of the products.

At the customer's request, OMRON will provide applicable third party certification documents identifying ratings and limitations of use that apply to the products. This information by itself is not sufficient for a complete determination of the suitability of the products in combination with the end product, machine, system, or other application or use.

The following are some examples of applications for which particular attention must be given. This is not intended to be an exhaustive list of all possible uses of the products, nor is it intended to imply that the uses listed may be suitable for the products:

- Outdoor use, uses involving potential chemical contamination or electrical interference, or conditions or uses not described in this catalog.
- Nuclear energy control systems, combustion systems, railroad systems, aviation systems, medical equipment, amusement machines, vehicles, safety equipment, and installations subject to separate industry or government regulations.
- Systems, machines, and equipment that could present a risk to life or property.

Please know and observe all prohibitions of use applicable to the products.

NEVER USE THE PRODUCTS FOR AN APPLICATION INVOLVING SERIOUS RISK TO LIFE OR PROPERTY WITHOUT ENSURING THAT THE SYSTEM AS A WHOLE HAS BEEN DESIGNED TO ADDRESS THE RISKS, AND THAT THE OMRON PRODUCTS ARE PROPERLY RATED AND INSTALLED FOR THE INTENDED USE WITHIN THE OVERALL EQUIPMENT OR SYSTEM.

### PROGRAMMABLE PRODUCTS

OMRON shall not be responsible for the user's programming of a programmable product, or any consequence thereof.

## Disclaimers

### CHANGE IN SPECIFICATIONS

Product specifications and accessories may be changed at any time based on improvements and other reasons.

It is our practice to change model numbers when published ratings or features are changed, or when significant construction changes are made. However, some specifications of the products may be changed without any notice. When in doubt, special model numbers may be assigned to fix or establish key specifications for your application on your request. Please consult with your OMRON representative at any time to confirm actual specifications of purchased products.

### DIMENSIONS AND WEIGHTS

Dimensions and weights are nominal and are not to be used for manufacturing purposes, even when tolerances are shown.

### PERFORMANCE DATA

Performance data given in this catalog is provided as a guide for the user in determining suitability and does not constitute a warranty. It may represent the result of OMRON's test conditions, and the users must correlate it to actual application requirements. Actual performance is subject to the OMRON Warranty and Limitations of Liability.

### ERRORS AND OMISSIONS

The information in this document has been carefully checked and is believed to be accurate; however, no responsibility is assumed for clerical, typographical, or proofreading errors, or omissions.

2008.11

In the interest of product improvement, specifications are subject to change without notice.

**OMRON Corporation**  
Industrial Automation Company

<http://www.ia.omron.com/>

(c)Copyright OMRON Corporation 2008 All Right Reserved.