

0.6V DUAL ADJUSTABLE PRECISION SHUNT REGULATOR

NEW PRODUCT

Description

The ZXRD060 is a 10-terminal adjustable dual shunt regulator offering excellent temperature stability and output handling capability. The ZXRD060 simplifies the design of isolated low voltage DC-DC regulators. With its low 0.6V FB pin, it can control the regulation of rails as low 0.6V. This makes it ideal for state of the art microprocessor/DSP and PLD core voltage POL converters.

The device open-collector output can operate from 0.2V to 18V and regulated output voltage can be set by selection of two external divider resistors.

Separating the input from the open collector output enables the ZXRD060 to be used to make low-cost low drop-out regulators operating at low input voltages.

The ZXRD060 is available in two grades with initial tolerances of 0.5% and 1% for the A and standard grades respectively. It is available in the space saving low profile 10 pin DFN2626P10 package.

Features

- Low reference voltage ($V_{FB} = 0.6V$)
- -40 to 125°C temperature range
- Reference voltage tolerance at 25°C
 - 0.5% ZXRD060A
 - 1% ZXRD060
- Typical temperature drift
 - <4 mV (0°C to 70°C)
 - <6 mV (-40°C to 85°C)
 - <12mV (-40°C to 125°C)
- 0.2V to 18V open-collector output
- High power supply rejection
 - (>45dB at 300kHz)
- Lead Free by design/RoHS Compliant (Note 1)
- "Green"/Halogen free device (Note 2)

Notes: 1. No purposefully added lead.
2. Diodes Inc.'s "Green" policy can be found on our website at http://www.diodes.com/products/lead_free/index.php.

Pin Assignments

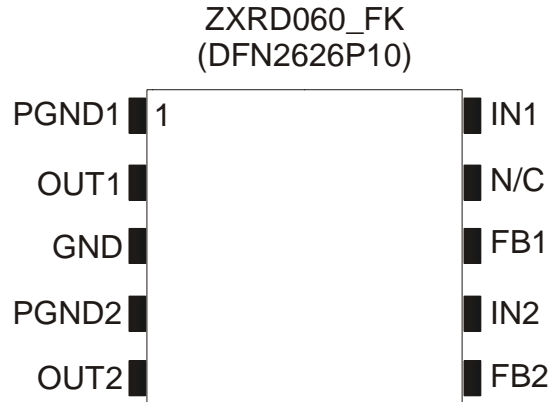

Applications

- Isolated DC-DC converters
- Core voltage POL
- Low Voltage Low-Dropout linear regulators
- Shunt regulators
- Adjustable voltage reference

Typical Application Circuit

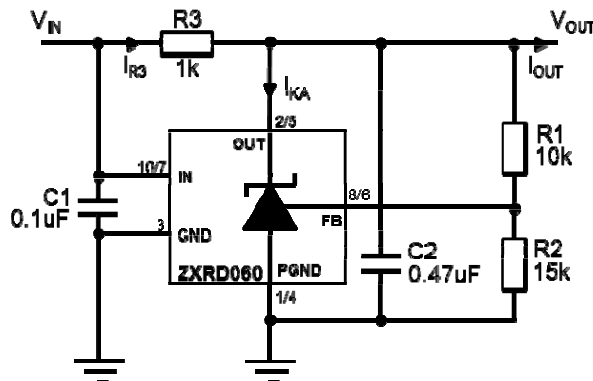

0.6V DUAL ADJUSTABLE PRECISION SHUNT REGULATOR

Pin Description

Pin (DFN)	Name	Function
1	PGND1	Power Ground 1: Ground return for emitter of output transistor: Connect PGND1/2 and GND together.
2	OUT1	Output 1. Connect a capacitor close to device between OUT1 and GND. See <i>Applications Information</i> section.
3	GND	Analog Ground: Ground return for reference and amplifiers: Connect GND and PGND1/2 together.
4	PGND2	Power Ground 2: Ground return for emitter of output transistor: Connect PGND1/2 and GND together.
5	OUT2	Output 2. Connect a capacitor close to device between OUT2 and GND. See <i>Applications Information</i> section.
6	FB2	Feedback Input 2. Regulates to 600mV nominal.
7	IN2	Supply Input 2. Connect a 0.1µF ceramic capacitor close to the device from IN2 to GND.
8	FB1	Feedback Input 1. Regulates to 600mV nominal.
9		No connection
10	IN1	Supply Input 1. Connect a 0.1µF ceramic capacitor close to the device from IN1 to GND.
Flag		Floating or connect to GND

Function Block Diagram

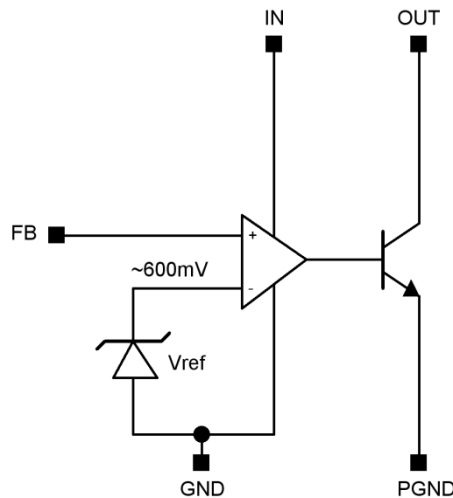

The ZXRD060 differs from most other shunt regulators in that it has separate input and output pins and a low voltage reference. This enables it to regulate rails down to 600mV and makes the part ideal for isolated power supply applications that use opto-couplers in the feedback loop and where the open-collector output is required to operate down to voltages as low as 200mV.

The wide input voltage range of 2V to 18V and output voltage range of 0.2V to 18V enables the ZXRD060 to be powered from an auxiliary rail, while controlling a master rail which is above the auxiliary rail voltage, or below the minimum V_{IN} voltage. This allows it to operate as a low-dropout voltage regulator for microprocessor/DSP/PLD cores.

As with other shunt regulators (and shunt references), the ZXRD060 compares its internal amplifier FB pin to a high accuracy internal reference; if FB is below the reference then OUT turns off, but if FB is above the reference then OUT sinks current – up to a maximum of 15mA.

0.6V DUAL ADJUSTABLE PRECISION SHUNT REGULATOR

Absolute Maximum Ratings (Voltages to GND Unless Otherwise Stated)

Symbol	Parameter	Rating	Unit
V _{IN}	IN Voltage relative to GND	20	V
V _{OUT}	OUT Voltage relative to GND	20	V
V _{FB}	FB Voltage relative to GND	20	V
P _{GND}	PGND Voltage relative to GND	-0.3 to +0.3	V
I _{OUT}	OUT Pin Current	20	mA
T _J	Operating Junction Temperature	-40 to 150	°C
T _{ST}	Storage Temperature	55 to 150	°C

Stresses greater than the 'Absolute Maximum Ratings' specified above, may cause permanent damage to the device. These are stress ratings only; functional operation of the device at these or any other conditions exceeding those indicated in this specification is not implied. Device reliability may be affected by exposure to absolute maximum rating conditions for extended periods of time.

Semiconductor devices are ESD sensitive and may be damaged by exposure to ESD events. Suitable ESD precautions should be taken when handling and transporting these devices.

Package Thermal Data

Package	θ_{JA}	P _{DIS} T _A = 25°C, T _J = 150°C
DFN2626P10	152° C/W	0.8W

Recommended Operating Conditions

Symbol	Parameter	Min	Max	Units
V _{IN}	IN Voltage Range (0 to 125°C)	2	18	V
V _{IN}	IN Voltage Range (-40 to 0°C)	2.2	18	
V _{OUT}	OUT Voltage Range	0.2	18	mA
I _{OUT}	OUT Pin Current	0.3	15	
T _A	Operating Ambient Temperature Range	-40	125	°C

NEW PRODUCT

0.6V DUAL ADJUSTABLE PRECISION SHUNT REGULATOR

Electrical Characteristics

$T_A = 25^\circ\text{C}$, $V_{IN} = 3.3\text{V}$, $V_{OUT} = V_{FB}$, $I_{OUT} = 5\text{mA}$ unless otherwise stated (Note 3).

Symbol	Parameter	Conditions		Min	Typ	Max	Units	
V_{FB}	Feedback voltage		ZXRD060A	0.597	0.6	0.603	V	
			ZXRD060	0.594	0.6	0.606		
		$T_A = 0^\circ\text{C}$ to 85°C	ZXRD060A	0.595		0.605		
			ZXRD060	0.592		0.608		
		$T_A = -40^\circ\text{C}$ to 85°C	ZXRD060A	0.594		0.606		
			ZXRD060	0.591		0.609		
		$T_A = -40^\circ\text{C}$ to 125°C	ZXRD060A	0.593		0.607		
			ZXRD060	0.590		0.610		
FB_{LOAD}	Feedback pin load regulation	$I_{OUT} = 1$ to 15mA			3.8	6	mV	
			$T_A = -40$ to 125°C					10
FB_{LINE}	Feedback pin line regulation	$V_{IN} = 2\text{V}$ to 18V			0.1	1	mV	
		$V_{IN} = 2.2\text{V}$ to 18V	$T_A = -40$ to 125°C					1.5
FB_{OVR}	Output voltage regulation	$V_{OUT} = 0.2\text{V}$ to 18V , $I_{OUT} = 1\text{mA}$ (Ref. Figure 1)				1	mV	
			$T_A = -40$ to 125°C					1.5
I_{FB}	FB input bias current	$V_{IN} = 18\text{V}$			-45		nA	
			$T_A = -40$ to 125°C	-200				0
I_{IN}	Input current	$V_{IN} = 2\text{V}$ to 18V	$I_{OUT} = 0.3\text{mA}$			0.35	0.7	mA
				$T_A = -40$ to 125°C				
		$V_{IN} = 2\text{V}$ to 18V	$I_{OUT} = 10\text{mA}$			0.48	1	mA
				$T_A = -40$ to 125°C				
$I_{OUT(LK)}$	OUT leakage current	$V_{IN} = 18\text{V}$, $V_{OUT} = 18\text{V}$, $V_{FB} = 0\text{V}$				0.1	μA	
			$T_A = 125^\circ\text{C}$					1
Z_{OUT}	Dynamic Output Impedance	$I_{OUT} = 1$ to 15mA $f < 1\text{kHz}$			0.25	0.4	Ω	
			$T_A = -40$ to 125°C					0.6
PSRR	Power supply rejection ratio	$f = 300\text{kHz}$ $V_{AC} = 0.3V_{PP}$			>45		dB	
BW	Amplifier Unity Gain Frequency	Ref: Fig 2			600		kHz	
G	Amplifier Transconductance				5000		mA/V	

Note: 3. Production testing of the device is performed at 25°C . Functional operation of the device and parameters specified over the operating temperature range are guaranteed by design, characterisation and process control.

NEW PRODUCT

0.6V DUAL ADJUSTABLE PRECISION SHUNT REGULATOR

Typical Characteristics

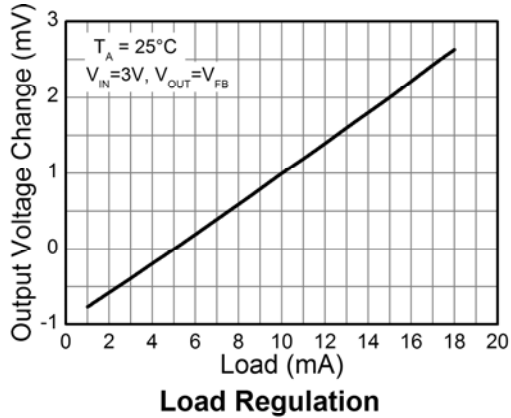

Load Regulation

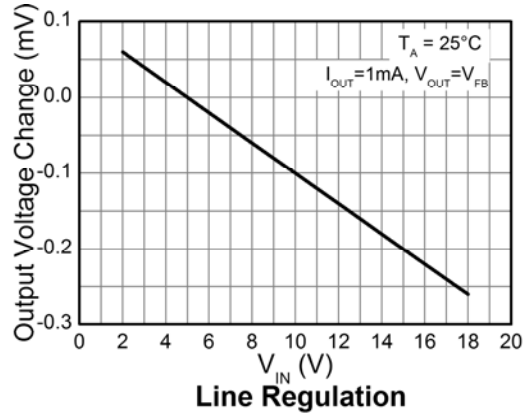

Line Regulation

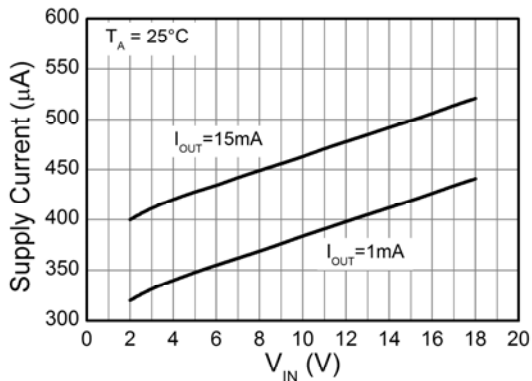

Supply Current vs Input Voltage

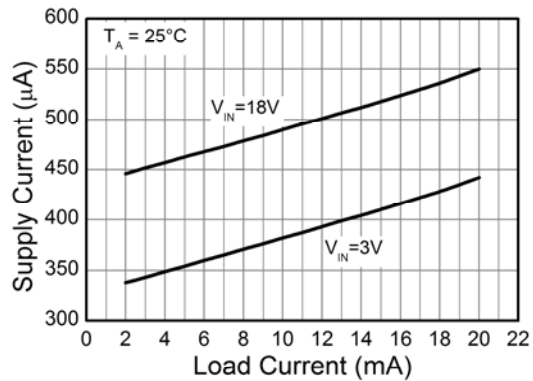

Supply Current vs Load Current

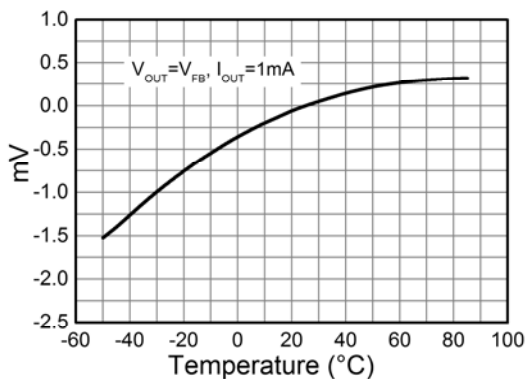

OUT Voltage Change with Temperature

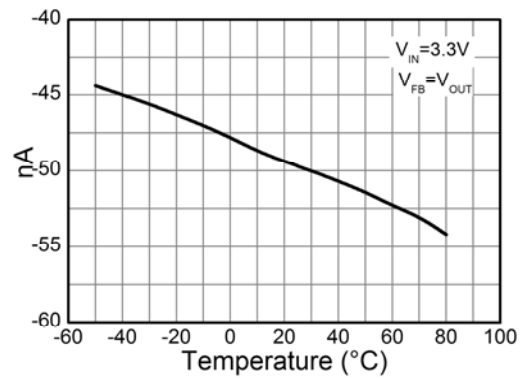

FB Bias Current vs Temperature

NEW PRODUCT

0.6V DUAL ADJUSTABLE PRECISION SHUNT REGULATOR

Typical Operating Conditions (cont.)

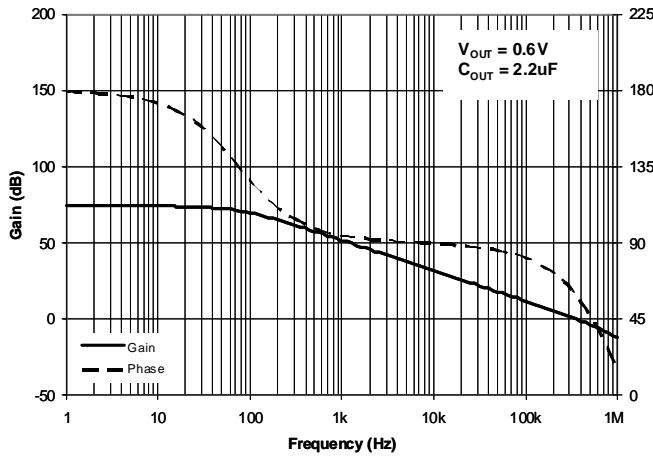

Gain and Phase vs Frequency, $V_{OUT}=0.6V$

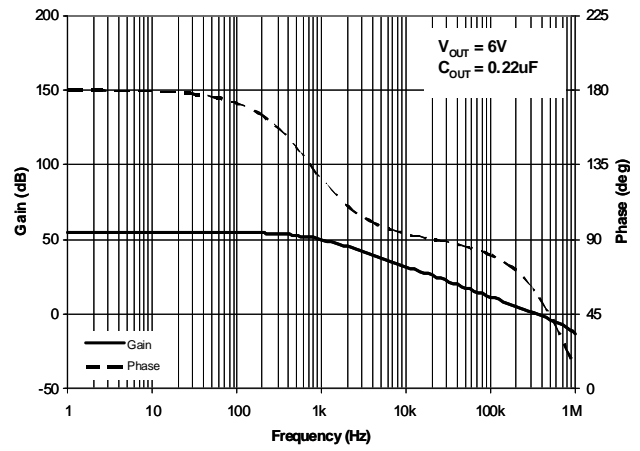

Gain and Phase vs Frequency, $V_{OUT}=6V$

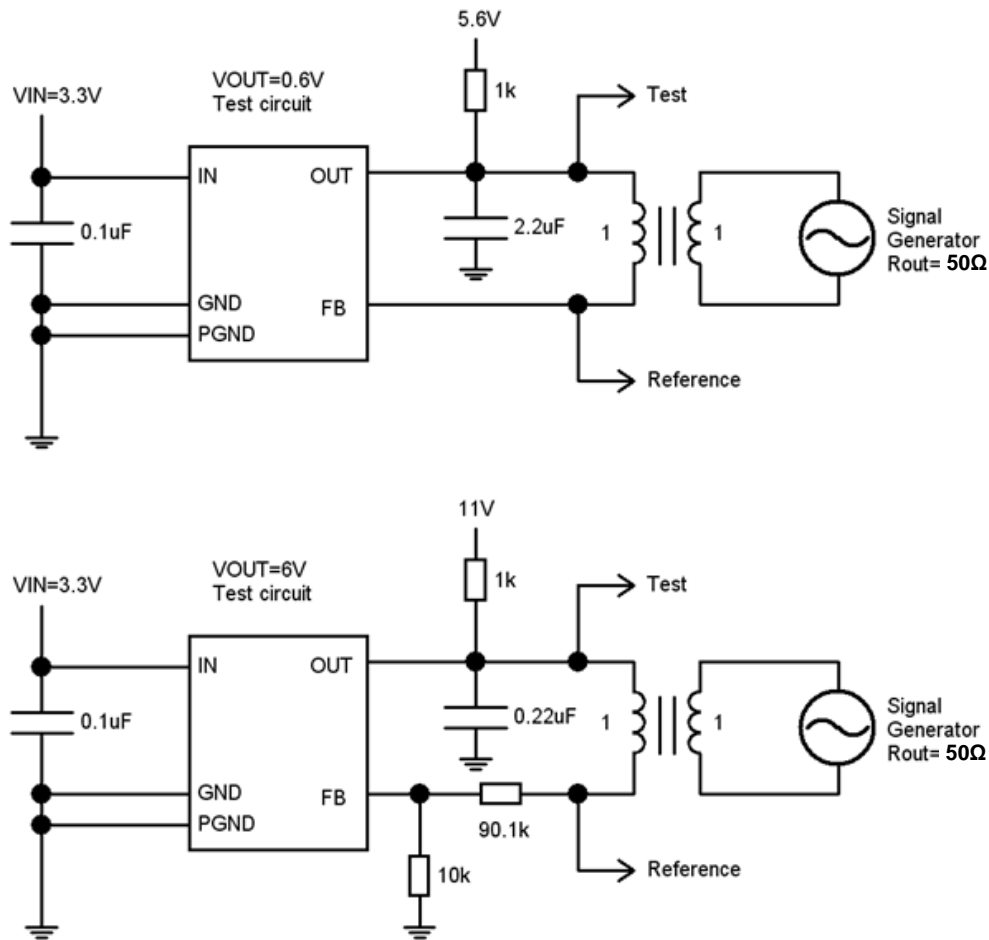

Fig. 2 Test Circuits for Gain and Phase Plots

NEW PRODUCT

0.6V DUAL ADJUSTABLE PRECISION SHUNT REGULATOR

Applications Information

The following show some typical application examples for the ZXRD060. It is recommended to include the compensation capacitor C2 to guarantee stability. C2 may range in value from 0.1µF to 10µF depending on the application. The time constant formed by C2 and R3 should be greater than 1ms multiplied by the feedback factor $R2/(R1 + R2)$.

Both C1 and C2 should be as close to the ZXRD060 as possible and connected to it with the shortest possible track. In the case of fig 9 and fig10, it means the opto-coupler will have to be carefully positioned to enable this.

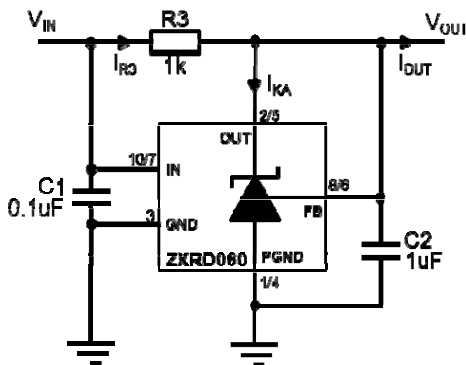

$$V_{OUT} = V_{REF}$$

$$R3 = \frac{V_{IN} - V_{OUT}}{I_{R3}}$$

Fig.3 0.6V Shunt Regulator

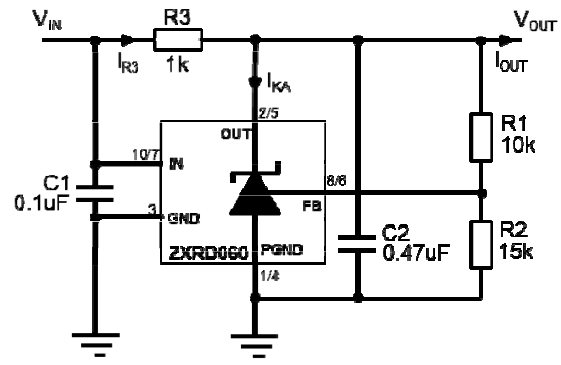

$$V_{OUT} = V_{REF} \left(1 + \frac{R1}{R2} \right)$$

$$R3 = \frac{V_{IN} - V_{OUT}}{I_{R3}}$$

Fig.4 1.0V Shunt Regulator

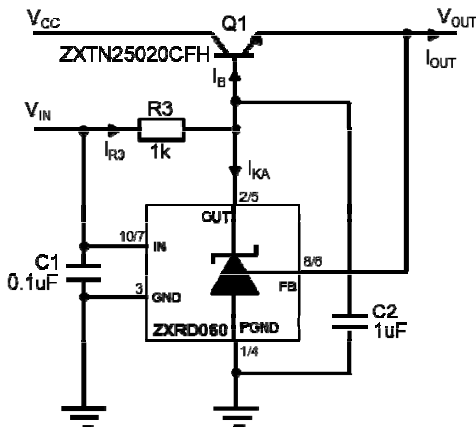

$$V_{OUT} = V_{REF}$$

Fig.5 0.6V Series LDO regulator

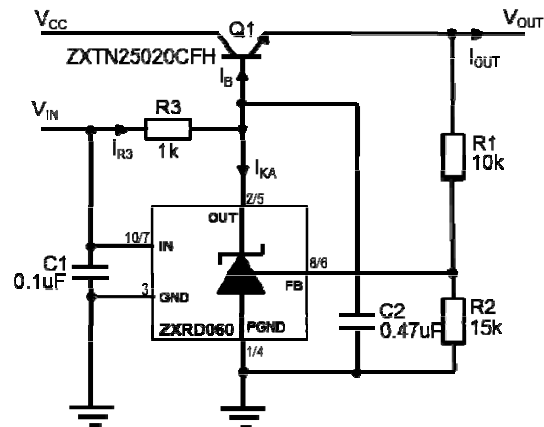

$$V_{OUT} = V_{REF} \left(1 + \frac{R1}{R2} \right)$$

Fig.6 1.0V Series LDO regulator

Design guide

1. Determine I_{OUT} and choose a suitable transistor taking power dissipation into consideration.
2. Determine I_B from $I_B = \frac{I_{OUT(max)}}{(hFE(min) + 1)}$
3. Determine I_{R3} from $I_{R3} \geq I_B + I_{KA(min)}$. The design of the ZXRD060 effectively means there is no $I_{KA(min)}$ limitation as in conventional references. There is only an output leakage current which is a maximum of 1µA. Nevertheless, it is necessary to determine an $I_{KA(min)}$ to ensure that the device operates within its linear range at all times. $I_{KA(min)} \geq 10\mu A$ should be adequate for this.
4. Determine R3 from $R3 = \frac{V_{IN} - (V_{OUT} + V_{BE})}{I_{R3}}$.
5. Although unlikely to be a problem, ensure that $I_{R3} \leq 15$ mA.

0.6V DUAL ADJUSTABLE PRECISION SHUNT REGULATOR

Applications Information (cont.)

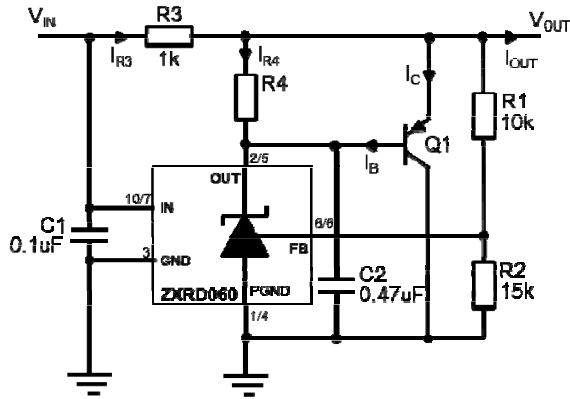

$$V_{OUT} = V_{REF} \left(1 + \frac{R1}{R2} \right)$$

$$(V_{OUT} \geq 0.2V + V_{BE})$$

$$R3 = \frac{V_{IN} - V_{OUT}}{I_{R3}}$$

Fig.7 1V Current-Boosted Shunt Regulator

Design guide

1. Determine I_{OUT} and choose a suitable transistor taking power dissipation into consideration.
2. Determine I_B from
$$I_B = \frac{I_{OUT(max)}}{(hFE(min) + 1)}$$
3. Determine I_{R3} from $I_{R3} = I_{OUT(max)}$
4. Determine $R3$ from
$$R3 = \frac{V_{IN} - V_{OUT}}{I_{R3}}$$
5. It is best to let the ZXR060 supply as much current as it can before bringing Q1 into conduction. Not only does this minimise the strain on Q1, it also guarantees the most stable operation. Choose a nominal value between 10mA and <15mA for this current, I_{R4} .
6. Calculate $R4$ from
$$R4 = \frac{V_{BE}}{I_{R4}}$$

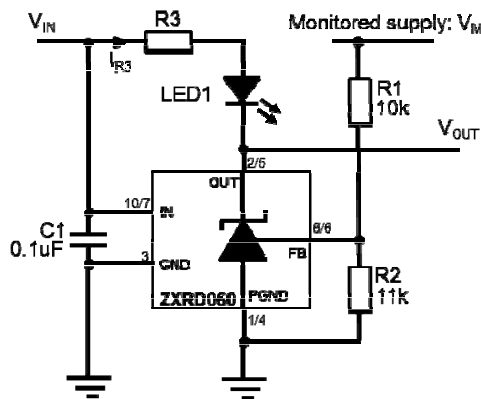

V_{OUT} goes low and LED1 is lit when monitored supply

$$V_M > V_{REF} \left(1 + \frac{R1}{R2} \right)$$

$$R3 = \frac{V_{IN} - (V_F + 0.2)}{I_{R3}}$$

$$15mA \geq I_{R3} \leq I_F(MAX)$$

V_F and I_F are forward voltage drop and current of LED1.

Fig. 8 1.15V Over-Voltage Indicator

0.6V DUAL ADJUSTABLE PRECISION SHUNT REGULATOR

Applications Information (cont.)

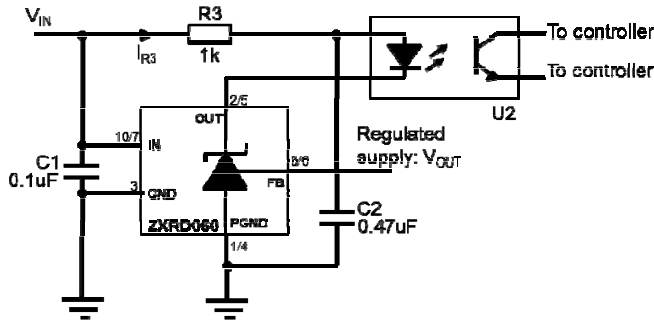

$$15\text{mA} \geq I_{R3} \leq I_F(\text{MAX})$$

$$R3 = \frac{V_{IN} - (V_F + 0.2)}{I_{R3}}$$

$$V_{OUT} = V_{REF}$$

Fig.9 Opto-Isolated 0.6V Shunt Regulator

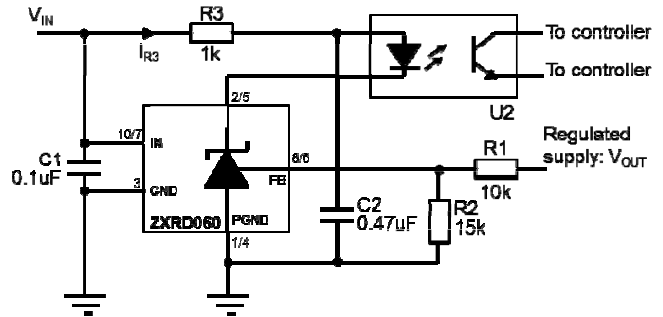

$$15\text{mA} \geq I_{R3} \leq I_F(\text{MAX})$$

$$R3 = \frac{V_{IN} - (V_F + 0.2)}{I_{R3}}$$

$$V_{OUT} = V_{REF} \left(1 + \frac{R1}{R2} \right)$$

Fig. 10 Opto-Isolated 1.0V Shunt Regulator

V_F and I_F are forward voltage drop and forward current respectively for the opto-coupler LED.
More applications information is available in the following publications which can be found on Diodes' web site.

- AN58 - Designing with Diodes' References – *Shunt Regulation*
- AN59 - Designing with Diodes' References – *Series Regulation*
- AN60 - Designing with Diodes' References – *Fixed Regulators and Opto-Isolation*
- AN61 - Designing with Diodes' References – *Extending the operating voltage range*
- AN62 - Designing with Diodes' References – *Other Applications*
- AN63 - Designing with Diodes' References – *ZXRE060 Low Voltage Regulator*

0.6V DUAL ADJUSTABLE PRECISION SHUNT REGULATOR

Ordering Information

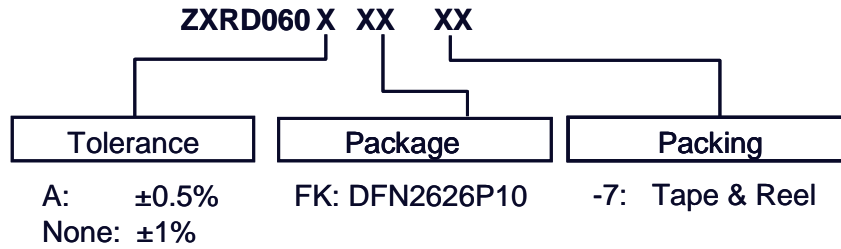

Tol.	Order Code	Part	Identification Code	Reel Size	Tape Width	Quantity/Reel
0.5%	ZXRD060AFK-7	DFN2626P10	S6A	7", 180mm	8mm	3000
1%	ZXRD060FK-7	DFN2626P10	S06	7", 180mm	8mm	3000

For packaging details, go to our website at <http://www.diodes.com/datasheets/ap02007.pdf>

Marking Information

DFN2626P10

Top View

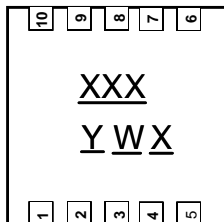

XXX : Identification code
Y : Year : 0~9
W : Week : A~Z : 1~26 week;
 a~z : 27~52 week;
 z : represents 52 and 53
X : A~Z : Internal Code

NEW PRODUCT



0.6V DUAL ADJUSTABLE PRECISION SHUNT REGULATOR

Package Outline Dimensions (All Dimensions in mm)

DFN2626P10

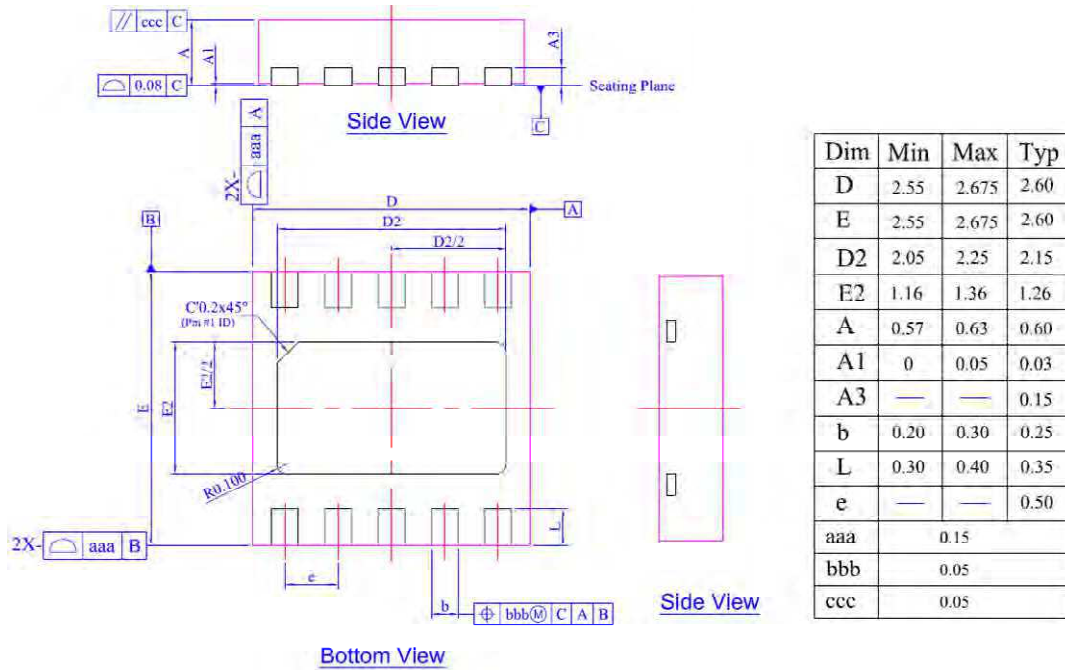

NEW PRODUCT

0.6V DUAL ADJUSTABLE PRECISION SHUNT REGULATOR**IMPORTANT NOTICE**

DIODES INCORPORATED MAKES NO WARRANTY OF ANY KIND, EXPRESS OR IMPLIED, WITH REGARDS TO THIS DOCUMENT, INCLUDING, BUT NOT LIMITED TO, THE IMPLIED WARRANTIES OF MERCHANTABILITY AND FITNESS FOR A PARTICULAR PURPOSE (AND THEIR EQUIVALENTS UNDER THE LAWS OF ANY JURISDICTION).

Diodes Incorporated and its subsidiaries reserve the right to make modifications, enhancements, improvements, corrections or other changes without further notice to this document and any product described herein. Diodes Incorporated does not assume any liability arising out of the application or use of this document or any product described herein; neither does Diodes Incorporated convey any license under its patent or trademark rights, nor the rights of others. Any Customer or user of this document or products described herein in such applications shall assume all risks of such use and will agree to hold Diodes Incorporated and all the companies whose products are represented on Diodes Incorporated website, harmless against all damages.

Diodes Incorporated does not warrant or accept any liability whatsoever in respect of any products purchased through unauthorized sales channel.

Should Customers purchase or use Diodes Incorporated products for any unintended or unauthorized application, Customers shall indemnify and hold Diodes Incorporated and its representatives harmless against all claims, damages, expenses, and attorney fees arising out of, directly or indirectly, any claim of personal injury or death associated with such unintended or unauthorized application.

Products described herein may be covered by one or more United States, international or foreign patents pending. Product names and markings noted herein may also be covered by one or more United States, international or foreign trademarks.

LIFE SUPPORT

Diodes Incorporated products are specifically not authorized for use as critical components in life support devices or systems without the express written approval of the Chief Executive Officer of Diodes Incorporated. As used herein:

A. Life support devices or systems are devices or systems which:

1. are intended to implant into the body, or
2. support or sustain life and whose failure to perform when properly used in accordance with instructions for use provided in the labeling can be reasonably expected to result in significant injury to the user.

B. A critical component is any component in a life support device or system whose failure to perform can be reasonably expected to cause the failure of the life support device or to affect its safety or effectiveness.

Customers represent that they have all necessary expertise in the safety and regulatory ramifications of their life support devices or systems, and acknowledge and agree that they are solely responsible for all legal, regulatory and safety-related requirements concerning their products and any use of Diodes Incorporated products in such safety-critical, life support devices or systems, notwithstanding any devices- or systems-related information or support that may be provided by Diodes Incorporated. Further, Customers must fully indemnify Diodes Incorporated and its representatives against any damages arising out of the use of Diodes Incorporated products in such safety-critical, life support devices or systems.

Copyright © 2011, Diodes Incorporated

www.diodes.com