

1-Mbit (128K x 8) Static RAM

Features

- Pin- and function-compatible with CY7C109B/CY7C1009B
- High speed
 - $t_{AA} = 10 \text{ ns}$
- Low active power
 - $I_{CC} = 80 \text{ mA @ } 10 \text{ ns}$
- Low CMOS standby power
 - $I_{SB2} = 3 \text{ mA}$
- 2.0V Data Retention
- Automatic power-down when deselected
- TTL-compatible inputs and outputs
- Easy memory expansion with \overline{CE}_1 , CE_2 and \overline{OE} options
- CY7C109D available in Pb-free 32-pin 400-Mil wide Molded SOJ and 32-pin TSOP I packages. CY7C1009D available in Pb-free 32-pin 300-Mil wide Molded SOJ package

Functional Description ^[1]

The CY7C109D/CY7C1009D is a high-performance CMOS static RAM organized as 131,072 words by 8 bits. Easy memory expansion is provided by an active LOW Chip Enable (\overline{CE}_1), an active HIGH Chip Enable (CE_2), an active LOW Output Enable (\overline{OE}), and tri-state drivers. The eight input and output pins (IO_0 through IO_7) are placed in a high-impedance state when:

- Deselected (\overline{CE}_1 HIGH or CE_2 LOW),
- Outputs are disabled (\overline{OE} HIGH),
- When the write operation is active (\overline{CE}_1 LOW, CE_2 HIGH, and \overline{WE} LOW)

Write to the device by taking Chip Enable One (\overline{CE}_1) and Write Enable (\overline{WE}) inputs LOW and Chip Enable Two (CE_2) input HIGH. Data on the eight IO pins (IO_0 through IO_7) is then written into the location specified on the address pins (A_0 through A_{16}).

Read from the device by taking Chip Enable One (\overline{CE}_1) and Output Enable (\overline{OE}) LOW while forcing Write Enable (\overline{WE}) and Chip Enable Two (CE_2) HIGH. Under these conditions, the contents of the memory location specified by the address pins appears on the IO pins.

Logic Block Diagram

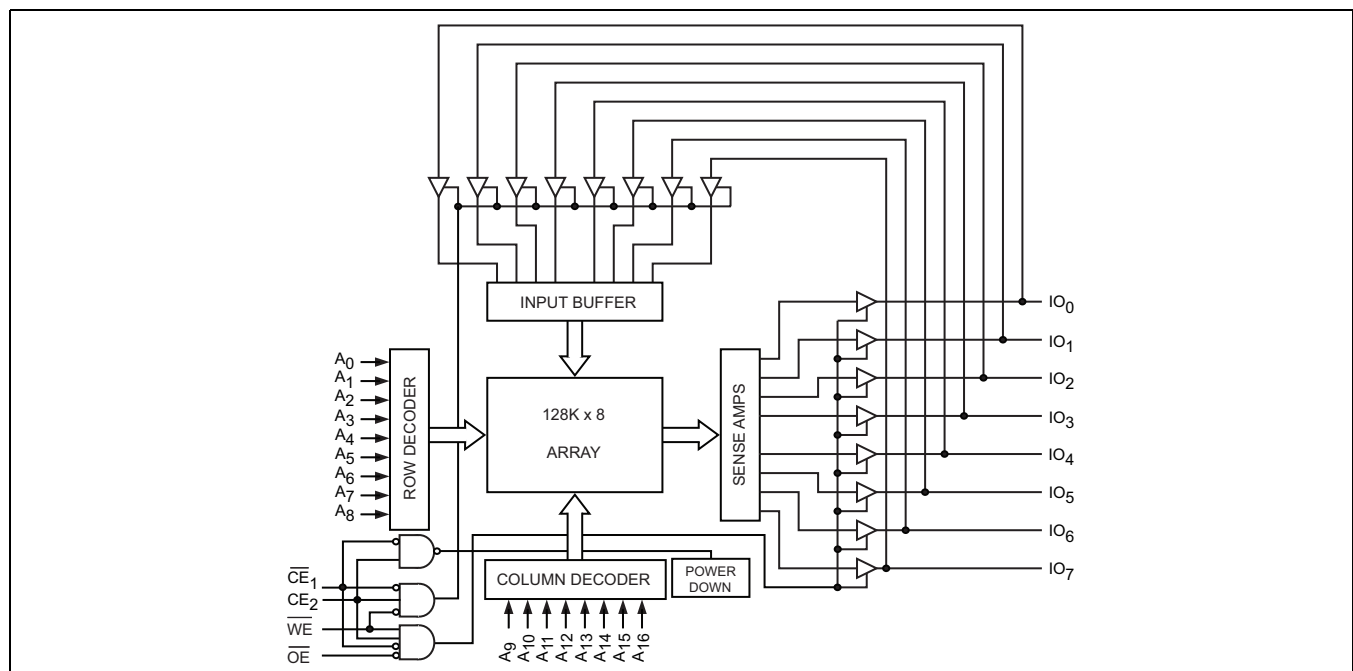

Note

1. For guidelines on SRAM system design, please refer to the 'System Design Guidelines' Cypress application note, available on the internet at www.cypress.com.

Pin Configurations [2]

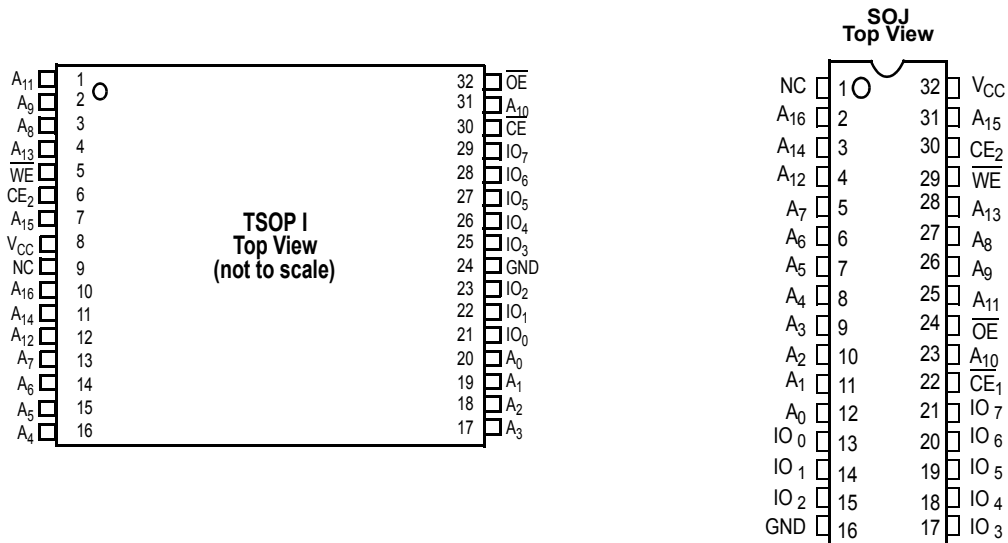

Selection Guide

	CY7C109D-10 CY7C1009D-10	Unit
Maximum Access Time	10	ns
Maximum Operating Current	80	mA
Maximum CMOS Standby Current	3	mA

Note

2. NC pins are not connected on the die.

Maximum Ratings

Exceeding the maximum ratings may impair the useful life of the device. These user guidelines are not tested.

Storage Temperature -65°C to +150°C

Ambient Temperature with Power Applied..... -55°C to +125°C

Supply Voltage on V_{CC} to Relative GND ^[3] ... -0.5V to +6.0V

DC Voltage Applied to Outputs in High-Z State ^[3] -0.5V to V_{CC} + 0.5V

DC Input Voltage ^[3] -0.5V to V_{CC} + 0.5V

Current into Outputs (LOW) 20 mA

Static Discharge Voltage..... > 2001V (per MIL-STD-883, Method 3015)

Latch-up Current > 200 mA

Operating Range

Range	Ambient Temperature	V _{CC}	Speed
Industrial	-40°C to +85°C	5V ± 0.5V	10 ns

Electrical Characteristics (Over the Operating Range)

Parameter	Description	Test Conditions	7C109D-10 7C1009D-10		Unit
			Min	Max	
V _{OH}	Output HIGH Voltage	I _{OH} = -4.0 mA	2.4		V
V _{OL}	Output LOW Voltage	I _{OL} = 8.0 mA		0.4	V
V _{IH}	Input HIGH Voltage		2.2	V _{CC} + 0.5	V
V _{IL}	Input LOW Voltage ^[3]		-0.5	0.8	V
I _{IX}	Input Leakage Current	GND ≤ V _I ≤ V _{CC}	-1	+1	μA
I _{OZ}	Output Leakage Current	GND ≤ V _I ≤ V _{CC} , Output Disabled	-1	+1	μA
I _{CC}	V _{CC} Operating Supply Current	V _{CC} = Max, I _{OUT} = 0 mA, f = f _{max} = 1/t _{RC}	100 MHz	80	mA
			83 MHz	72	mA
			66 MHz	58	mA
			40 MHz	37	mA
I _{SB1}	Automatic CE Power-Down Current—TTL Inputs	Max V _{CC} , CE ₁ ≥ V _{IH} or CE ₂ ≤ V _{IL} , V _{IN} ≥ V _{IH} or V _{IN} ≤ V _{IL} , f = f _{max}		10	mA
I _{SB2}	Automatic CE Power-Down Current—CMOS Inputs	Max V _{CC} , CE ₁ ≥ V _{CC} - 0.3V, or CE ₂ ≤ 0.3V, V _{IN} ≥ V _{CC} - 0.3V, or V _{IN} ≤ 0.3V, f = 0		3	mA

Note

3. V_{IL}(min) = -2.0V and V_{IH}(max) = V_{CC} + 1V for pulse durations of less than 5 ns.

Capacitance [4]

Parameter	Description	Test Conditions	Max	Unit
C_{IN}	Input Capacitance	$T_A = 25^\circ\text{C}$, $f = 1\text{ MHz}$, $V_{CC} = 5.0\text{V}$	8	pF
C_{OUT}	Output Capacitance		8	pF

Thermal Resistance [4]

Parameter	Description	Test Conditions	300-Mil Wide SOJ	400-Mil Wide SOJ	TSOP I	Unit
Θ_{JA}	Thermal Resistance (Junction to Ambient)	Still Air, soldered on a 3×4.5 inch, four-layer printed circuit board	57.61	56.29	50.72	$^\circ\text{C/W}$
Θ_{JC}	Thermal Resistance (Junction to Case)		40.53	38.14	16.21	$^\circ\text{C/W}$

AC Test Loads and Waveforms [5]

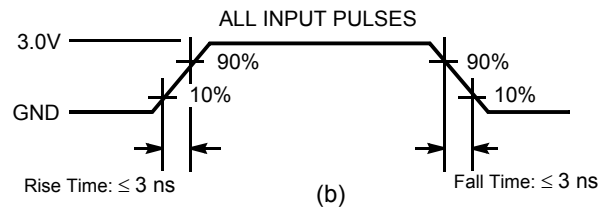
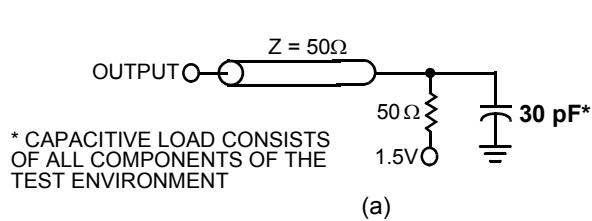

High-Z characteristics:

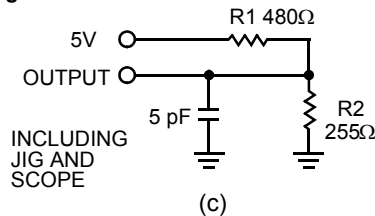

Notes

- Tested initially and after any design or process changes that may affect these parameters.
- AC characteristics (except High-Z) are tested using the load conditions shown in Figure (a). High-Z characteristics are tested for all speeds using the test load shown in Figure (c).

Switching Characteristics (Over the Operating Range) ^[6]

Parameter	Description	7C109D-10 7C1009D-10		Unit
		Min	Max	
Read Cycle				
$t_{power}^{[7]}$	V_{CC} (typical) to the first access	100		μs
t_{RC}	Read Cycle Time	10		ns
t_{AA}	Address to Data Valid		10	ns
t_{OHA}	Data Hold from Address Change	3		ns
t_{ACE}	\overline{CE}_1 LOW to Data Valid, CE_2 HIGH to Data Valid		10	ns
t_{DOE}	\overline{OE} LOW to Data Valid		5	ns
t_{LZOE}	\overline{OE} LOW to Low Z	0		ns
t_{HZOE}	\overline{OE} HIGH to High Z ^[8, 9]		5	ns
t_{LZCE}	\overline{CE}_1 LOW to Low Z, CE_2 HIGH to Low Z ^[9]	3		ns
t_{HZCE}	\overline{CE}_1 HIGH to High Z, CE_2 LOW to High Z ^[8, 9]		5	ns
$t_{PU}^{[10]}$	\overline{CE}_1 LOW to Power-Up, CE_2 HIGH to Power-Up	0		ns
$t_{PD}^{[10]}$	\overline{CE}_1 HIGH to Power-Down, CE_2 LOW to Power-Down		10	ns
Write Cycle ^[11, 12]				
t_{WC}	Write Cycle Time	10		ns
t_{SCE}	\overline{CE}_1 LOW to Write End, CE_2 HIGH to Write End	7		ns
t_{AW}	Address Set-Up to Write End	7		ns
t_{HA}	Address Hold from Write End	0		ns
t_{SA}	Address Set-Up to Write Start	0		ns
t_{PWE}	\overline{WE} Pulse Width	7		ns
t_{SD}	Data Set-Up to Write End	6		ns
t_{HD}	Data Hold from Write End	0		ns
t_{LZWE}	\overline{WE} HIGH to Low Z ^[9]	3		ns
t_{HZWE}	\overline{WE} LOW to High Z ^[8, 9]		5	ns

Notes

- Test conditions assume signal transition time of 3 ns or less, timing reference levels of 1.5V, input pulse levels of 0 to 3.0V, and output loading of the specified I_{OL}/I_{OH} and 30-pF load capacitance.
- t_{POWER} gives the minimum amount of time that the power supply should be at typical V_{CC} values until the first memory access can be performed
- t_{HZOE} , t_{HZCE} and t_{HZWE} are specified with a load capacitance of 5 pF as in part (c) of "AC Test Loads and Waveforms" ^[5] on page 4. Transition is measured when the outputs enter a high impedance state.
- At any given temperature and voltage condition, t_{HZCE} is less than t_{LZCE} , t_{HZOE} is less than t_{LZOE} , and t_{HZWE} is less than t_{LZWE} for any given device.
- This parameter is guaranteed by design and is not tested.
- The internal write time of the memory is defined by the overlap of \overline{CE}_1 LOW, CE_2 HIGH, and \overline{WE} LOW. \overline{CE}_1 and \overline{WE} must be LOW and CE_2 HIGH to initiate a write, and the transition of any of these signals can terminate the write. The input data set-up and hold timing should be referenced to the leading edge of the signal that terminates the write.
- The minimum write cycle time for Write Cycle No. 3 (\overline{WE} controlled, \overline{OE} LOW) is the sum of t_{HZWE} and t_{SD} .

Data Retention Characteristics (Over the Operating Range)

Parameter	Description	Conditions	Min	Max	Unit
V_{DR}	V_{CC} for Data Retention	$V_{CC} = V_{DR} = 2.0V$,	2.0		V
I_{CCDR}	Data Retention Current	$\overline{CE}_1 \geq V_{CC} - 0.3V$ or $CE_2 \leq 0.3V$, $V_{IN} \geq V_{CC} - 0.3V$ or $V_{IN} \leq 0.3V$		3	mA
$t_{CDR}^{[4]}$	Chip Deselect to Data Retention Time		0		ns
$t_R^{[13]}$	Operation Recovery Time		t_{RC}		ns

Data Retention Waveform

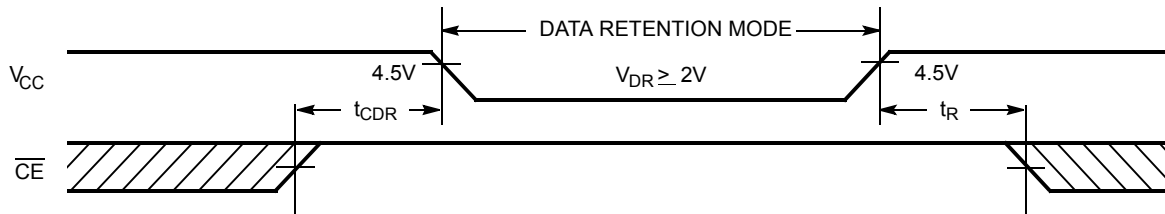

Switching Waveforms

Read Cycle No. 1 (Address Transition Controlled) [14, 15]

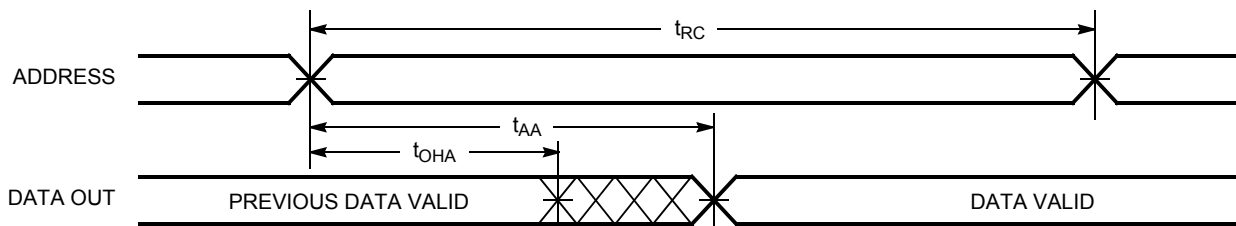

Read Cycle No. 2 (\overline{OE} Controlled) [15, 16]

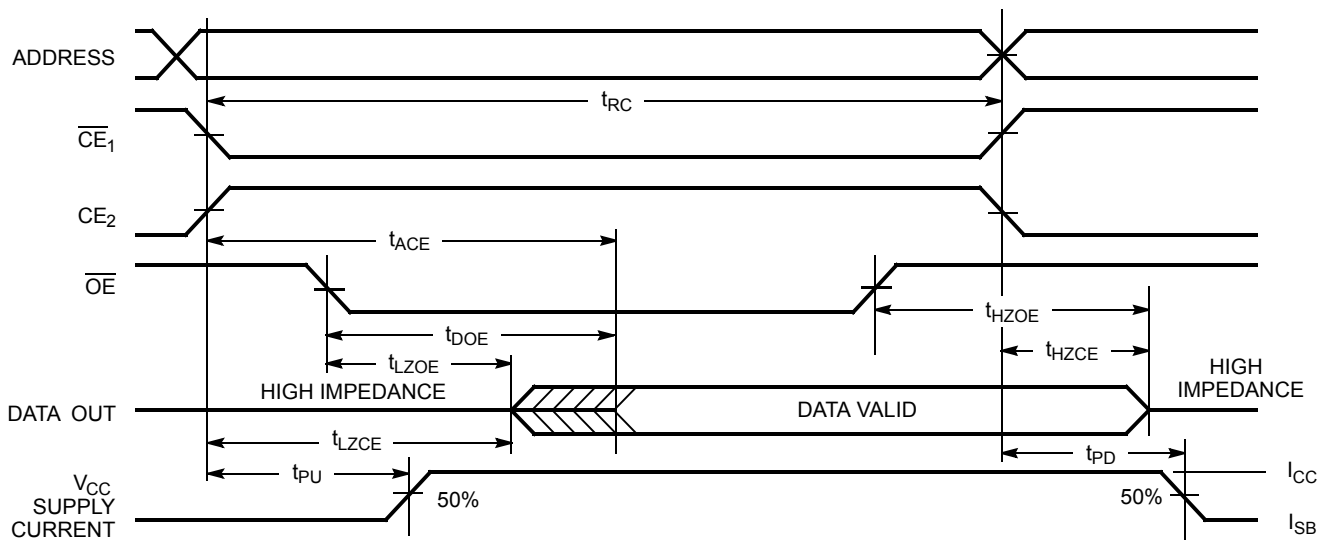

Notes

13. Full device operation requires linear V_{CC} ramp from V_{DR} to $V_{CC(min)} \geq 50 \mu s$ or stable at $V_{CC(min)} \geq 50 \mu s$.
14. Device is continuously selected. $\overline{OE}, \overline{CE}_1 = V_{IL}, CE_2 = V_{IH}$.
15. \overline{WE} is HIGH for read cycle.
16. Address valid prior to or coincident with \overline{CE}_1 transition LOW and CE_2 transition HIGH.

Switching Waveforms (continued)

Write Cycle No. 1 (\overline{CE}_1 or CE_2 Controlled) [17, 18]

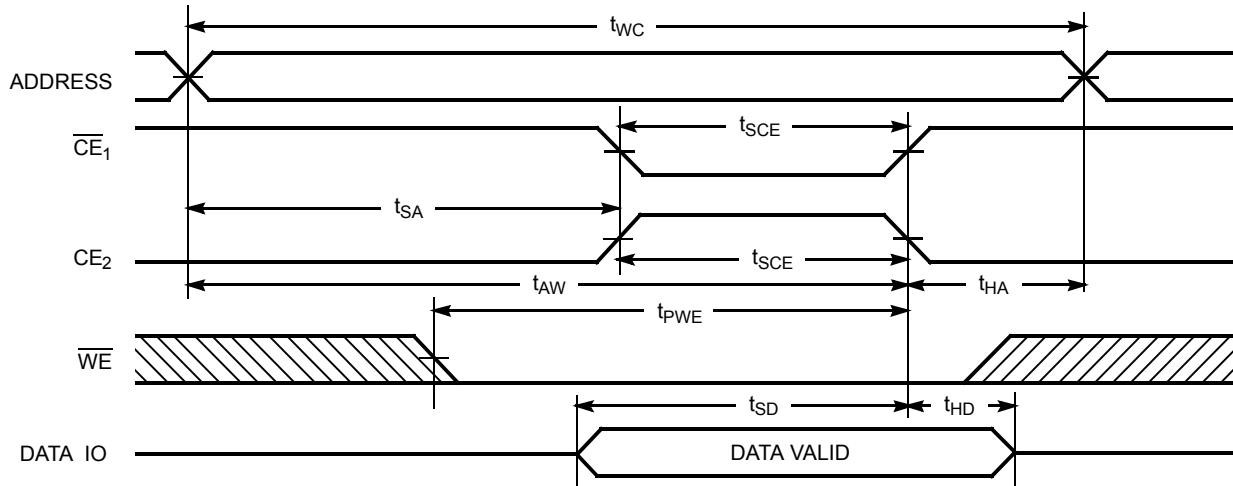

Write Cycle No. 2 (\overline{WE} Controlled, \overline{OE} HIGH During Write) [17, 18]

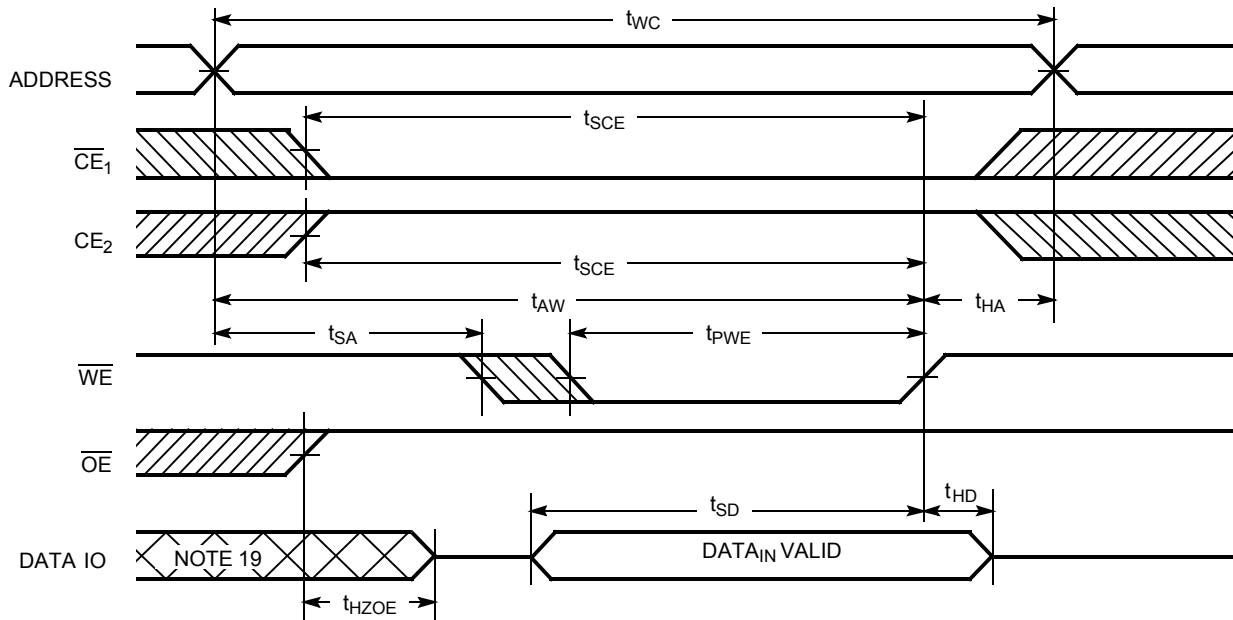

Notes

- 17. Data IO is high impedance if $\overline{OE} = V_{IH}$.
- 18. If \overline{CE}_1 goes HIGH or CE_2 goes LOW simultaneously with \overline{WE} going HIGH, the output remains in a high-impedance state.
- 19. During this period the IOs are in the output state and input signals should not be applied.

Switching Waveforms (continued)

Write Cycle No. 3 (\overline{WE} Controlled, \overline{OE} LOW) [12, 18]

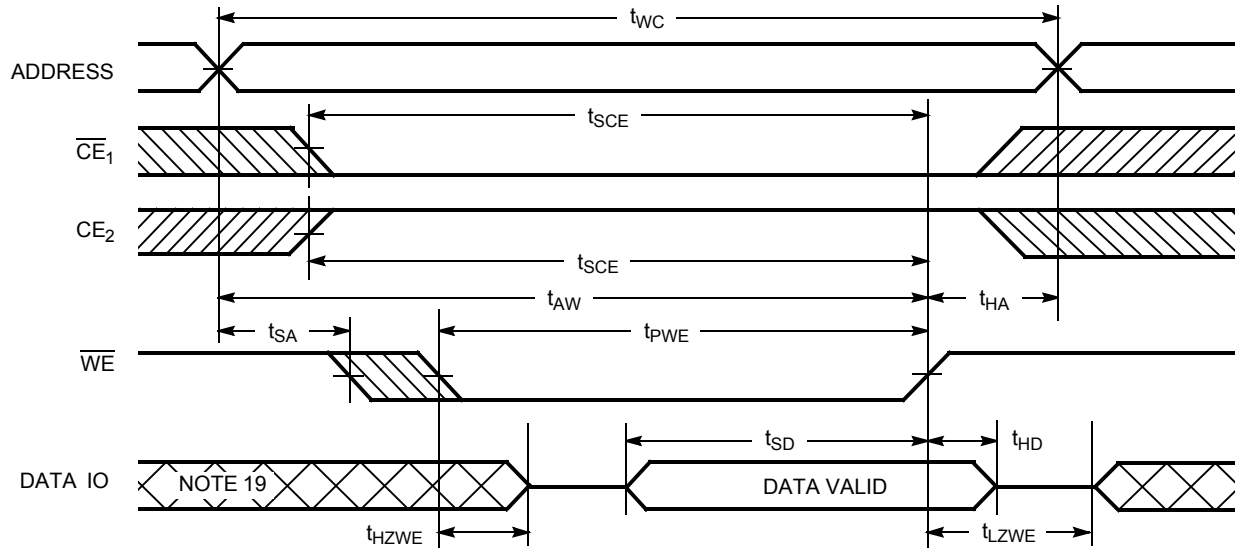

Truth Table

\overline{CE}_1	\overline{CE}_2	\overline{OE}	\overline{WE}	IO_0 - IO_7	Mode	Power
H	X	X	X	High Z	Power-down	Standby (I_{SB})
X	L	X	X	High Z	Power-down	Standby (I_{SB})
L	H	L	H	Data Out	Read	Active (I_{CC})
L	H	X	L	Data In	Write	Active (I_{CC})
L	H	H	H	High Z	Selected, Outputs Disabled	Active (I_{CC})

Ordering Information

Speed (ns)	Ordering Code	Package Diagram	Package Type	Operating Range
10	CY7C109D-10VXI	51-85033	32-pin (400-Mil) Molded SOJ (Pb-free)	Industrial
	CY7C109D-10ZXI	51-85056	32-pin TSOP Type I (Pb-free)	
	CY7C1009D-10VXI	51-85041	32-pin (300-Mil) Molded SOJ (Pb-free)	

Please contact your local Cypress sales representative for availability of these parts.

Package Diagrams

Figure 1. 32-pin (300-Mil) Molded SOJ, 51-85041

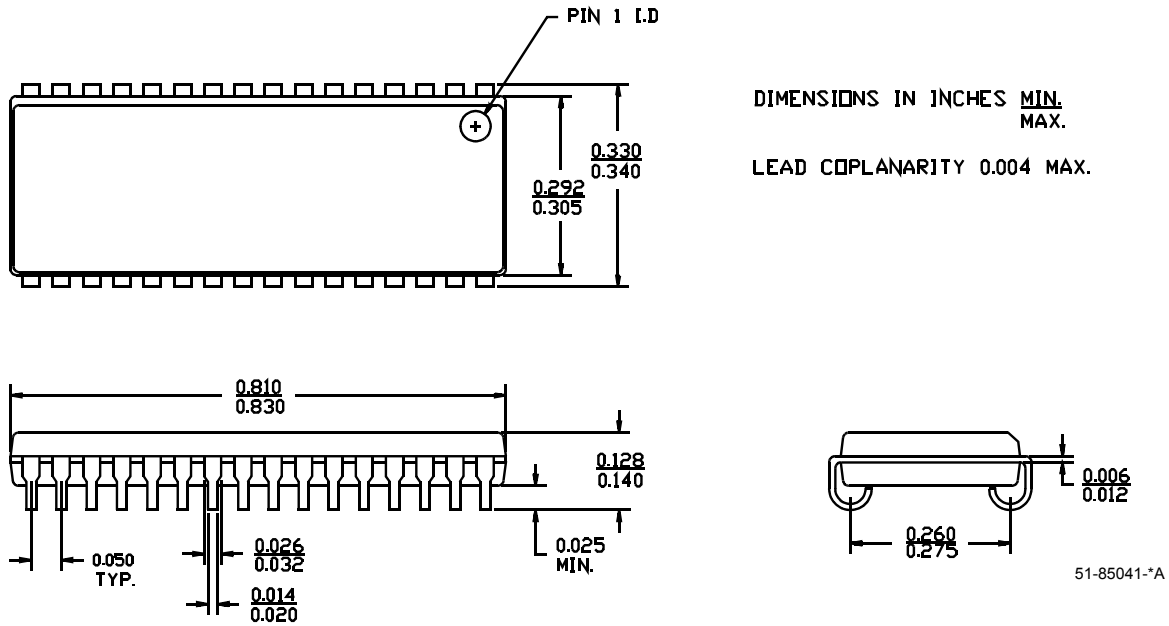
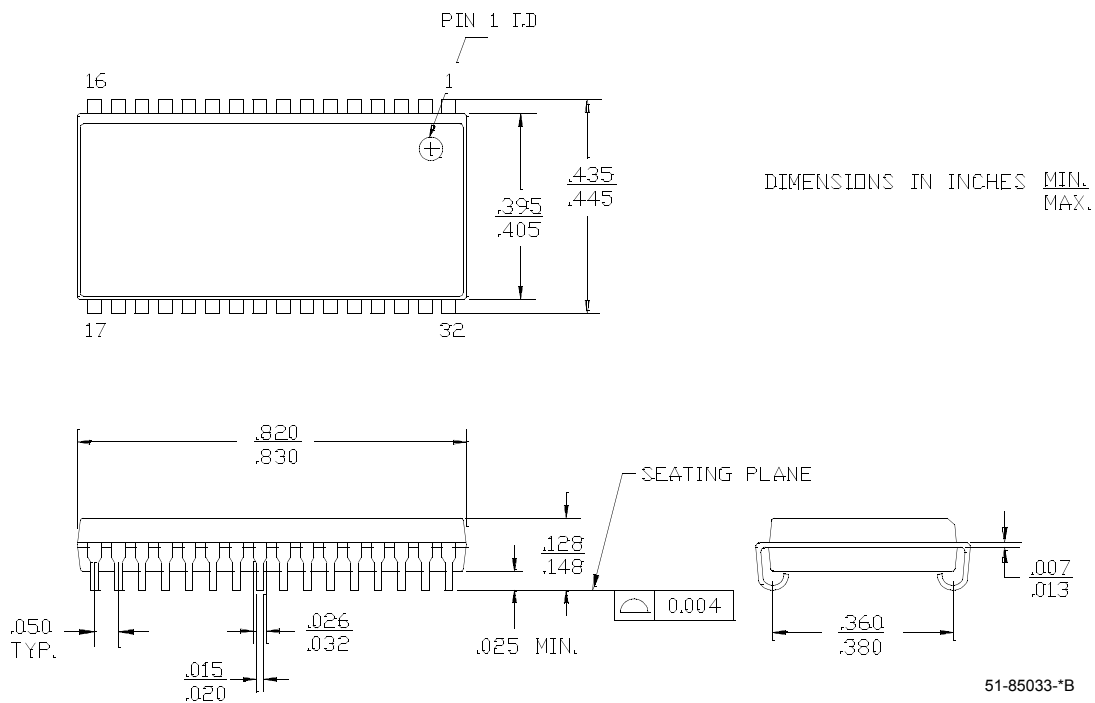
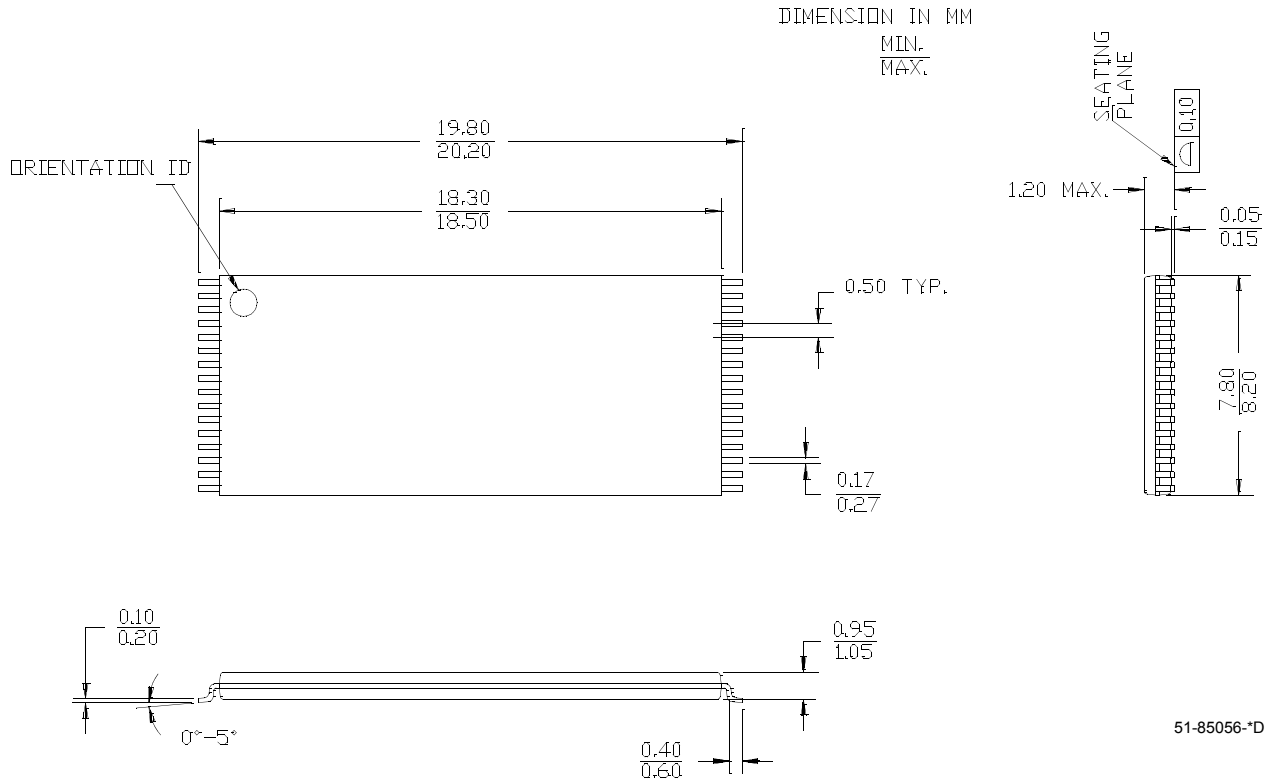

Figure 2. 32-pin (400-Mil) Molded SOJ, 51-85033



Package Diagrams (continued)

Figure 3. 32-pin Thin Small Outline Package Type I (8x20 mm), 51-85056



All product and company names mentioned in this document may be the trademarks of their respective holders.

Document History Page

Document Title: CY7C109D/CY7C1009D, 1-Mbit (128K x 8) Static RAM				
Document Number: 38-05468				
REV.	ECN NO.	Issue Date	Orig. of Change	Description of Change
**	201560	See ECN	SWI	Advance Information data sheet for C9 IPP
*A	233722	See ECN	RKF	DC parameters are modified as per EROS (Spec # 01-2165) Pb-free offering in Ordering Information
*B	262950	See ECN	RKF	Added Data Retention Characteristics table Added T _{power} Spec in Switching Characteristics Table Shaded Ordering Information
*C	See ECN	See ECN	RKF	Reduced Speed bins to -10 and -12 ns
*D	560995	See ECN	VKN	Converted from Preliminary to Final Removed Commercial Operating range Removed 12 ns speed bin Added I _{CC} values for the frequencies 83MHz, 66MHz and 40MHz Updated Thermal Resistance table Updated Ordering Information Table Changed Overshoot spec from V _{CC} +2V to V _{CC} +1V in footnote #3
*E	802877	See ECN	VKN	Changed I _{CC} spec from 60 mA to 80 mA for 100MHz, 55 mA to 72 mA for 83MHz, 45 mA to 58 mA for 66MHz, 30 mA to 37 mA for 40MHz