



Very high isolation voltages, up to 15kV, are achieved through the use of high vacuum reed switches with either Rhodium or Tungsten contacts and make these relays suitable for high reliability applications such as cardiac defibrillators, test equipment and high voltage power supplies.

The Rhodium contacts have low contact resistance while the Tungsten contacts can switch higher voltages.

Printed Circuit Board (PCB) or Panel mount, via nylon studs, versions are available.

Connection options include PCB, solder turret tag, flying lead and Faston\* style Spade Terminals.

Available as Form A (SPNO) or Form B (SPNC) contact configurations.

- **15kV Isolation**
- **Low Contact Resistance**
- **High Power Switching**
- **PCB or Panel Mount**
- **Flying Lead, Solder and Faston\* Style Spade Terminal Options**

Contact	Units	Conditions	10kV Form A			10kV Form B			15kV Form A		
			Rhodium	Tungsten		Rhodium	Tungsten		Tungsten		
<b>Contact Materials</b>											
Isolation Across Contacts	kV	DC or AC peak	10	10		10	10		15		
Max. Switching Power	W		50	50		50	50		50		
Max. Switching Voltage	V	DC or AC peak	1000	7000		1000	7000		10000		
Max. Switching Current	A	DC or AC peak	3	2		3	2		2		
Max. Current Carry	A	DC or AC peak	4	3		4	3		2		
Capacitance Across Contacts	pF	Coil/Screen Grounded	<0.2	<0.2		<0.2	<0.2		<0.2		
Lifetime	Operations	Dry Switching	10 <sup>9</sup>	10 <sup>9</sup>		10 <sup>9</sup>	10 <sup>9</sup>		10 <sup>9</sup>		
Lifetime	Operations	50W Switching	10 <sup>6</sup>	10 <sup>6</sup>		10 <sup>6</sup>	10 <sup>6</sup>		10 <sup>8</sup>		
Contact Resistance	mOhms	Maximum (Typical)	50 (15)	250 (100)		50 (15)	250 (100)		250 (100)		
Insulation Resistance	Ohms	Minimum (Typical)	10 <sup>10</sup> (10 <sup>13</sup> )	10 <sup>10</sup> (10 <sup>13</sup> )		10 <sup>10</sup> (10 <sup>13</sup> )	10 <sup>10</sup> (10 <sup>13</sup> )		10 <sup>10</sup> (10 <sup>13</sup> )		
<b>Coil at 20°C</b>											
Must Operate	V	DC	3.7	9	20	3.7	9	20	3.7	9	20
Must Release	V	DC	0.5	1.25	4	0.5	1.25	4	0.5	1.25	4
Operate Time	ms	Diode Fitted	3.0	3.0	3.0	2.0	2.0	2.0	3.0	3.0	3.0
Release Time	ms	Diode Fitted	2.0	2.0	2.0	3.0	3.0	3.0	2.0	2.0	2.0
Resistance	Ohms		28	150	780	38	240	925	16	95	350
<b>Construction</b>											
Isolation Contact to Coil	kV	DC or AC peak		17			17		17		
Insulation Resistance Contact											
to All Other Terminals	Ohms	Minimum (Typical)		10 <sup>10</sup> (10 <sup>13</sup> )			10 <sup>10</sup> (10 <sup>13</sup> )		10 <sup>10</sup> (10 <sup>13</sup> )		
<b>Environmental</b>											
Operating Temperature Range	°C			-20 to +70			-20 to +70		-20 to +70		
Weight	Version	Standard	Panel			Spade			Flying Lead		
	Form A	gm	23	28		29			38		
	Form B	gm	31	36		37			46		

**Part Numbering System**

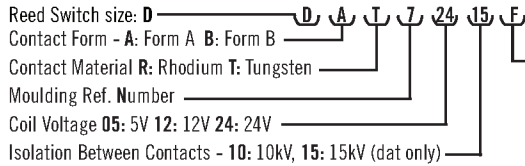

**Mounting Style:**

- No suffix: Standard PCB mount
- F: Flying Lead Contact Terminals
- P: Panel Mount via nylon studs, turret contact/coil terminals
- S: Panel Mount via nylon studs, Faston® style spade terminals

**STANDARD**

(e.g. DAT71210)

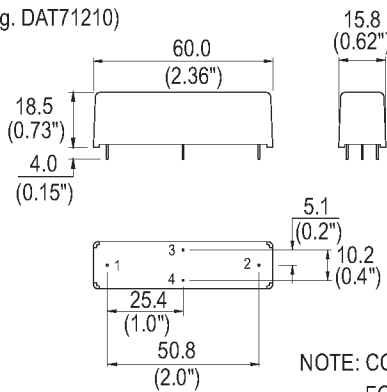

NOTE: COIL POLARITY IS IMPORTANT FOR FORM B VARIANT ONLY.

**PANEL MOUNT**

(e.g. DAT71210P)

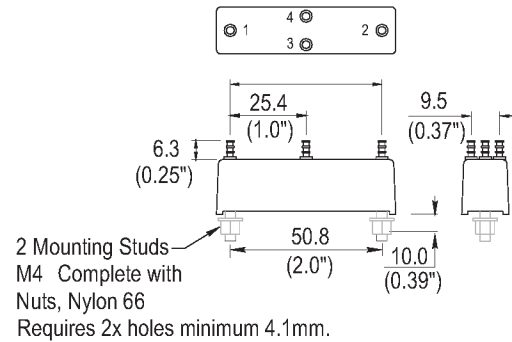

**SPADE TYPE**

(e.g. DAT71210S)

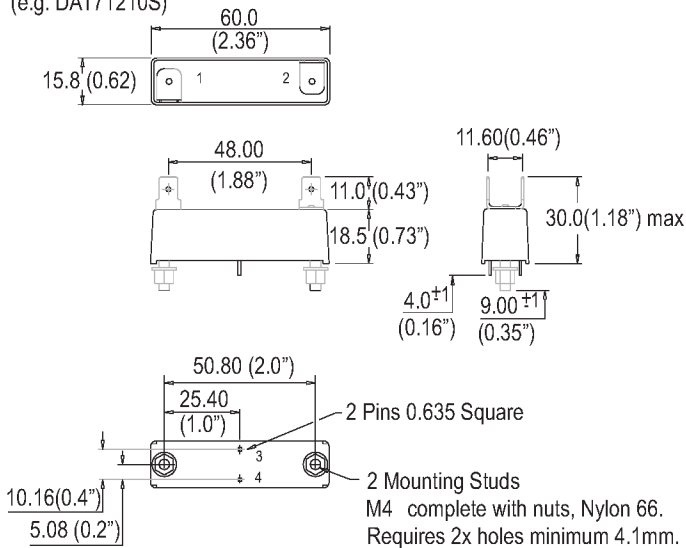

**FLYING LEAD**

(e.g. DAT71210F)

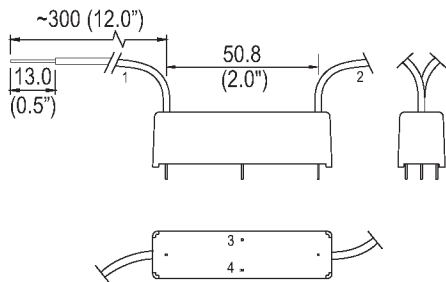

ISO9001 Certified

**USA**  
Sales & Tech Support(866) 258-5057  
Email: sales@cynergy3.com  
Cynergy3 Components  
2320 Paseo de las Americas, Suite 104  
San Diego, CA 92154

**EUROPE - UK**  
Telephone +44 (0) 1202 897969  
Fax +44 (0) 1202 891918  
Email:sales@cynergy3.com  
Cynergy3 Components Ltd.  
7 Cobham Road  
Ferndown Industrial Estate  
Wimborne, Dorset BH21 7PE

**ASIA - Thailand**  
Telephone +66 (0)2 665 2517  
Fax +66 (0)2 665 2588  
Cynergy 3 Components, Asia  
18/8 Fico Place 12th Floor  
Soi Sukhumvit 21 (Asoke)  
Klongtoey Nua, Wattana  
Bangkok, Thailand 10110