

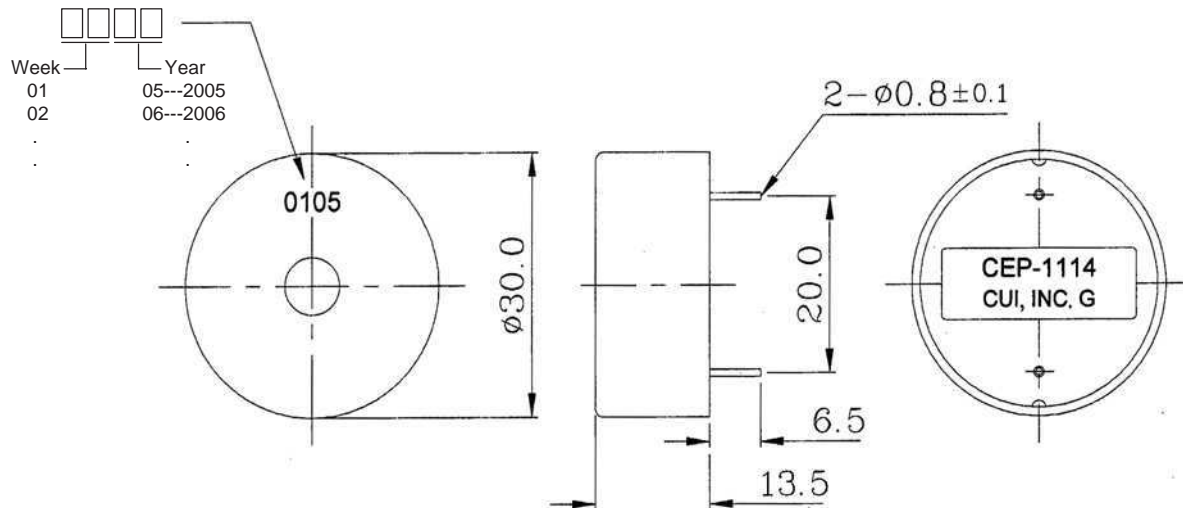
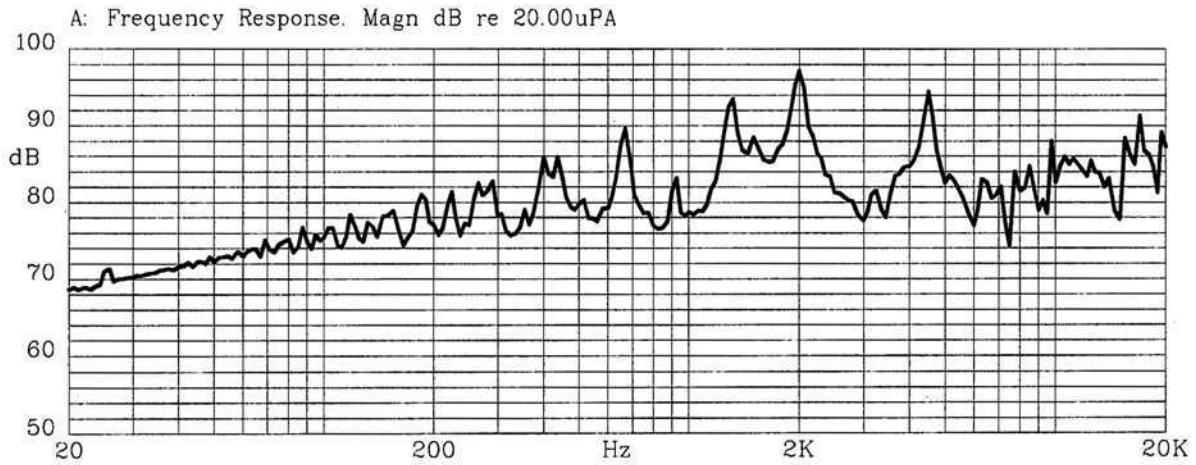
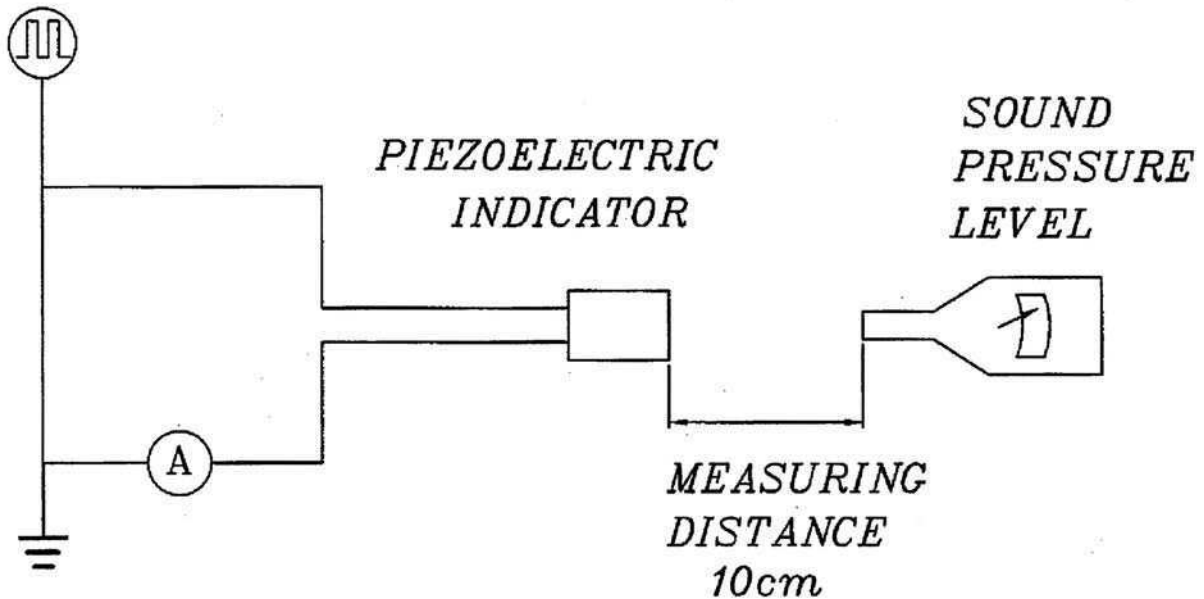

Specifications

Operating voltage	30 Vp-p max.	
Current consumption	11 mA max.	at 10 Vp-p, square wave, 2.0 KHz
Sound pressure level	93 db min.	at 10 cm / 10 Vp-p, square wave, 2.0 KHz
Electrostatic capacitance	45,000 pF \pm 30%	at 1 KHz / 1 V
Operating temperature	-30 ~ +80° C	
Storage temperature	-40 ~ +80° C	
Dimensions	ϕ 30.0 x H13.5 mm	
Weight	4.30 g max.	
Material	ABS UL-94 1/16" HB (Black)	
Terminal	Pin type (Au Plating)	
RoHS	yes	

Appearance Drawing

 Tolerance: \pm 0.5

Typical Frequency Response Curve

Measurement Method

S.P.L. Measuring Circuit
 Input Signal: 10 V p-p, 2.0 KHz, Square Wave
 Mic: RION UC 30
 S.G.: Hewlett Packard 33120A Function Generator or equivalent

Mechanical Characteristics

Item	Test Condition	Evaluation Standard
Solderability ¹	Lead terminals are immersed in rosin for 5 seconds and then immersed in solder bath of 270 ±5°C for 3 ±1 seconds.	90% min. of the lead terminals will be wet with solder. (Except the edge of the terminal)
Soldering Heat Resistance	Lead terminals are immersed up to 1.5mm from buzzer's body in solder bath of 300 ±5°C for 3 ±0.5 or 260 ±5°C for 10 ±1 seconds.	No interference in operation.
Terminal Mechanical Strength	For 10 seconds, the force of 9.8N (1.0kg) is applied to each terminal in axial direction.	No damage or cutting off.
Vibration	The buzzer should be measured after applying a vibration amplitude of 1.5 mm with 10 to 55 Hz band of vibration frequency to each of the 3 perpendicular directions for 2 hours.	The value of oscillation frequency/current consumption should be ±10% of the initial measurements. The SPL should be within ±10dB compared with the initial measurement.
Drop Test	The part will be dropped from a height of 75 cm onto a 40 mm thick wooden board 3 times in 3 axes (X, Y, Z) for a total of 9 drops.	

Notes: 1. Not recommended for wave soldering

Environment Test

Item	Test Condition	Evaluation Standard
High temp. test	After being placed in a chamber at +80°C for 240 hours.	The buzzer will be measured after being placed at +25°C for 4 hours. The value of the oscillation frequency/current consumption should be ±10% compared to the initial measurements. The SPL should be within ±10dB compared to the initial measurements.
Low temp. test	After being placed in a chamber at -40°C for 240 hours.	
Humidity test	After being placed in a chamber at +40°C and 90±5% relative humidity for 240 hours.	
Temp. cycle test	The part shall be subjected to 5 cycles. One cycle will consist of:	

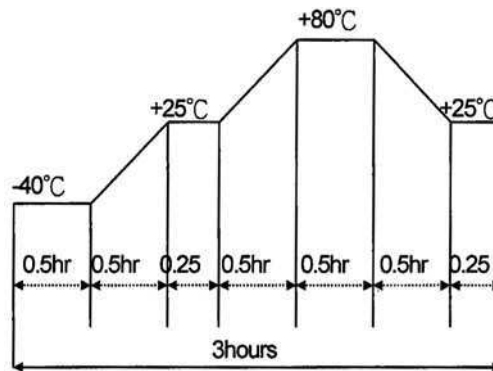



Reliability Test

Item	Test Condition	Evaluation Standard
Operating (Life Test)	1. Continuous life test: The part will be subjected to 48 hours of continuous operation at +65°C with rated voltage applied. 2. Intermittent life test: A duty cycle of 1 minute on, 1 minute off, a minimum of 5,000 times at room temp (+25 ±2°C) with rated volt age applied.	The buzzer will be measured after being placed at +25°C for 4 hours. The value of the oscillation frequency/current consumption should be ±10% compared to the initial measurements. The SPL should be within ±10dB compared to the initial measurements.

Test Conditions

Standard Test Condition	a) Temperature: +5 ~ +35°C	b) Humidity: 45 - 85%	c) Pressure: 860-1060 mbar
Judgement Test Condition	a) Temperature: +25 ±2°C	b) Humidity: 60 - 70%	c) Pressure: 860-1060 mbar



Packaging

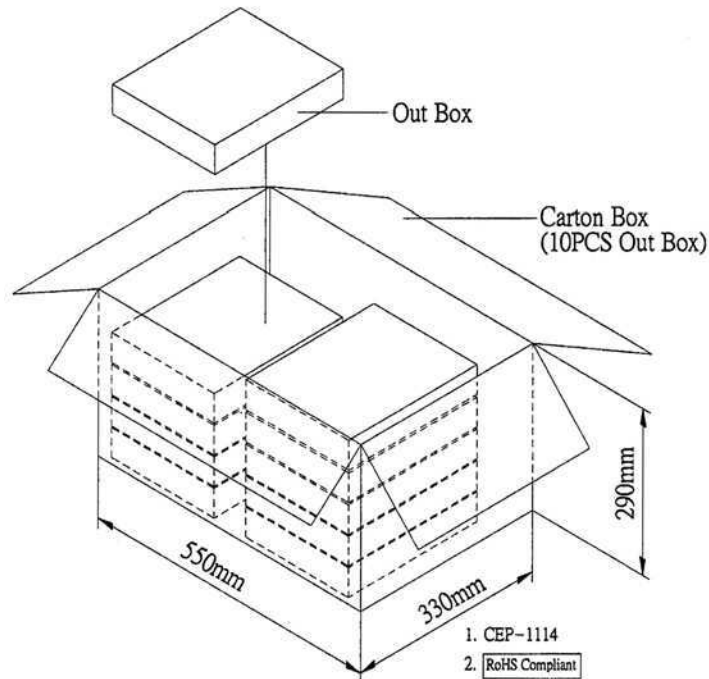
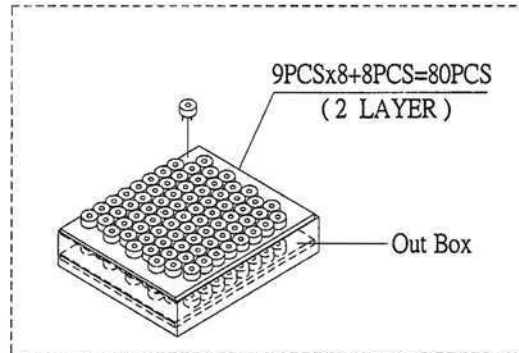

Out Box	310mmx248mmx49mm	2x80PCS=160PCS
Carton Box	550mmx330mmx290mm	160PCSx10=1,600PCS