

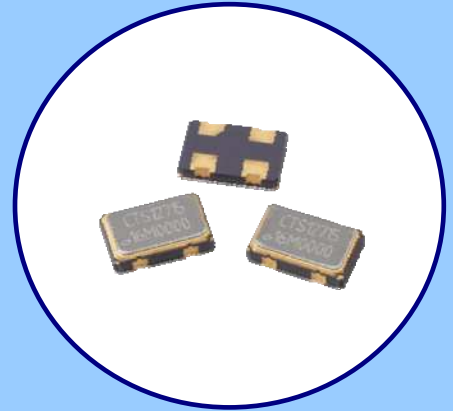

FEATURES

- Standard 5.0mm x 3.2mm 4-Pad Surface Mount Package
- HCMOS/TTL Compatible Output
- Fundamental and 3rd Overtone Crystal Designs
- Frequency Range 1 – 160 MHz
- Frequency Stability ± 50 ppm Standard, ± 25 ppm and ± 20 ppm Available
- Operating Voltages +1.8Vdc, +2.5Vdc, +3.3Vdc or +5.0Vdc
- Operating Temperature to -40°C to +85°C
- Output Enable Standard
- Tape & Reel Packaging Available
- RoHS/Green Compliant (6/6)



APPLICATIONS

Model 636 is ideal for applications; such as digital video, networking equipment, broadband access, Ethernet/Gigabit Ethernet, microprocessors/DSP/FPGA, storage area networks, computers and peripherals, cameras and other portable devices to name a few.

ORDERING INFORMATION

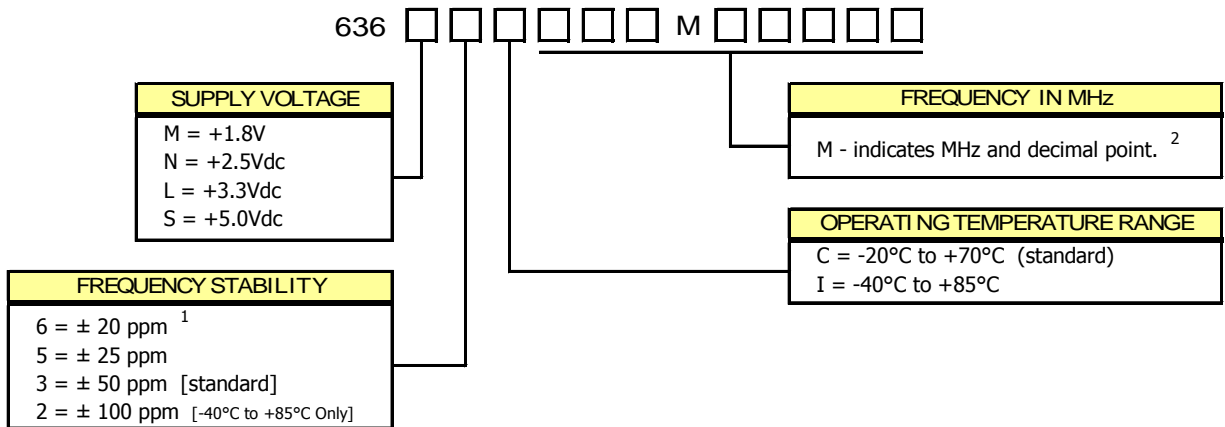

1] 6I Stability/Temperature combination is not available.
 2] Frequency is recorded with three leading significant digits before the 'M' and 5 significant digits after the 'M' (including zeros).
 [Ex. XXXMXXXXX, (0004M00000 (014M31818) (125M00000)]

Not all performance combinations and frequencies may be available.
 Contact your local CTS Representative or CTS Customer Service for availability.

PACKAGING INFORMATION

Device quantity is 3,000 pieces maximum per reel.

DIMENSIONS IN MILLIMETERS

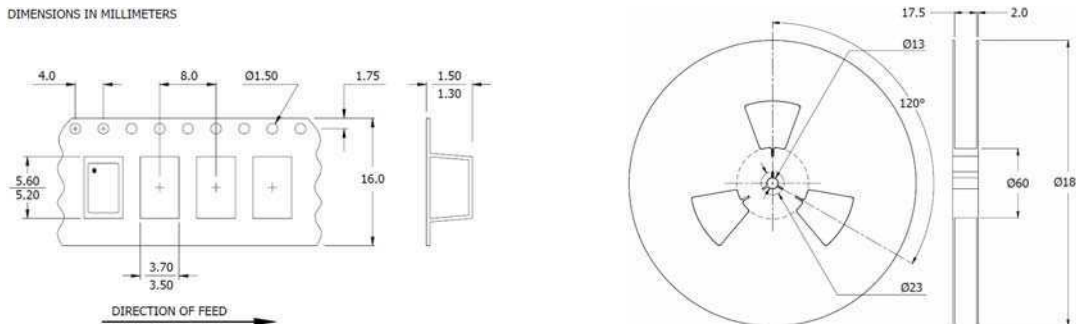

ELECTRICAL CHARACTERISTICS

PARAMETER	SYMBOL	CONDITIONS	MIN	TYP	MAX	UNIT		
Maximum Supply Voltage	V_{CC}	-	-0.5	-	7.0	V		
Storage Temperature	T_{STG}	-	-55	-	125	°C		
Frequency Range	f_0	-	1.0	-	160	MHz		
Frequency Stability [See Note 1 and Ordering Information]	$\Delta f/f_0$	-	-	-	20,25, 50 or 100	± ppm		
Aging	$\Delta f/f_0$	-	-	-	3	± ppm/yr		
Operating Temperature Commercial Industrial	T_A	-	-20 -40	25	70 85	°C		
Supply Voltage Model 636M Model 636N Model 636L Model 636S	V_{CC}	± 10 %	1.62 2.25 2.97 4.50	1.8 2.5 3.3 5.0	1.98 2.75 3.63 5.50	V		
Supply Current Model 636M [+1.8V]	I_{CC}	$C_L = 15pF$ 1.0 MHz to 34.999 MHz 35 MHz to 60 MHz 60.001 MHz to 99.999 MHz 100 MHz to 106.250 MHz 106.251 MHz to 160 MHz	- - - - -	- - - - -	8 15 25 35 35	mA		
Model 636N [+2.5V]		1.0 MHz to 34.999 MHz 35 MHz to 60 MHz 60.001 MHz to 99.999 MHz 100 MHz to 106.250 MHz 106.251 MHz to 160 MHz	- - - - -	- - - - -	10 20 30 40 40			
Model 636L [+3.3V]		1.0 MHz to 34.999 MHz 35 MHz to 60 MHz 60.001 MHz to 99.999 MHz 100 MHz to 106.250 MHz 106.251 MHz to 160 MHz	- - - - -	- - - - -	16 25 40 50 50			
Model 636S [+5.0]		1.0 MHz to 34.999 MHz 35 MHz to 60 MHz 60.001 MHz to 99.999 MHz 100 MHz to 106.250 MHz	- - - -	- - - -	25 50 60 80			
Output Load Model 636M Model 636N & 636L		C_L	1.0 MHz to 160 MHz	-	-		15	pF
Model 636S			1.0 MHz to 50 MHz 50.001 MHz to 160 MHz	-	-		30 15	
			1.0 MHz to 50 MHz 50.001 MHz to 80 MHz 80.001 MHz to 106.250 MHz	-	-		50 30 15	
Output Voltage Levels Logic '1' Level Logic '0' Level		V_{OH} V_{OL}	CMOS Load CMOS Load	90% V_{CC} -	- -		- 10% V_{CC}	V
Output Current Logic '1' Level (M,N,L,S) Logic '0' Level (M,N,L,S)		I_{OH} I_{OL}	$V_{OH} = 90\%V_{CC}$ $V_{OL} = 10\%V_{CC}$	- -	- -		-2, -4, -8, -16 +2, +4, +8, +16	mA
Output Duty Cycle		SYM	@ 50% Level	45	-		55	%
Rise and Fall Time Model 636M, 636N & 636L	T_R, T_F	@ 10% - 90% Levels, $C_L = 15pF$ 1.0 MHz to 50 MHz 50.001 MHz to 125 MHz 125.001 MHz to 160 MHz	- - -	6 3 1.5	10 5 2.5	ns		
Model 636S		1.0 MHz to 20 MHz 20.001 MHz to 50 MHz 50.001 MHz to 106.250 MHz	- - -	6 3 1.5	8 5 2			
Start Up Time		T_S	Application of V_{CC}	-	5		10	ms
Period Jitter, Pk-Pk Period Jitter, RMS Phase Jitter, RMS		- - -	- - Bandwidth 12 kHz - 20 MHz	- - -	- - -		100 25 1	ps

Notes:
1. Inclusive of initial tolerance at time of shipment, changes in supply voltage, load, temperature and aging.

ELECTRICAL CHARACTERISTICS

	PARAMETER	SYMBOL	CONDITIONS	MIN	TYP	MAX	UNIT
ELECTRICAL PARAMETERS	Enable Function						
	Enable Input Voltage	V _{IH}	Pin 1 Logic '1', Output Enabled	1.26	-	-	V
	Model 636M		Pin 1 Logic '1', Output Enabled	1.75	-	-	
	Model 636N		Pin 1 Logic '1', Output Enabled	2.0	-	-	
	Model 636S		Pin 1 Logic '1', Output Enabled	4.0	-	-	
	Disable Input Voltage	V _{IL}	Pin 1 Logic '0', Output Disabled	-	-	0.3	
Model 636M,636N,636L	Pin 1 Logic '0', Output Disabled		-	-	0.8		
	Enable Time (M,N,L,S)	T _{PLZ}	Pin 1 Logic '1'	-	-	10	ms
	Standby Current	I _{ST}	Pin 1 Logic '0', Output Disabled	-	-	10	µA

LVC MOS OUTPUT WAVEFORM

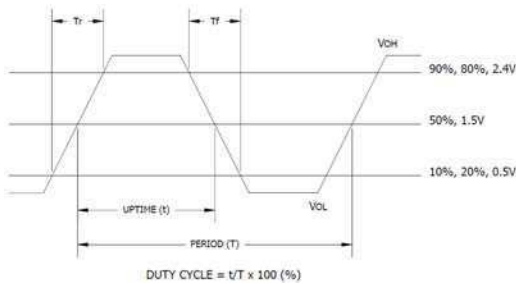

TEST CIRCUIT, CMOS LOAD

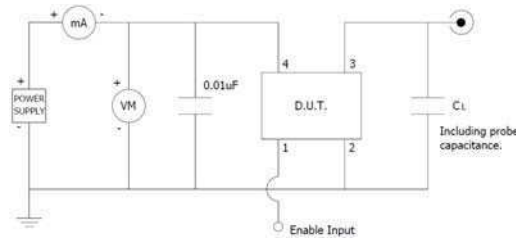

ENABLE TRUTH TABLE

PIN 1	PIN 3
Logic '1'	Output
Open	Output
Logic '0'	High Imp.

MECHANICAL SPECIFICATIONS

PACKAGE DRAWING

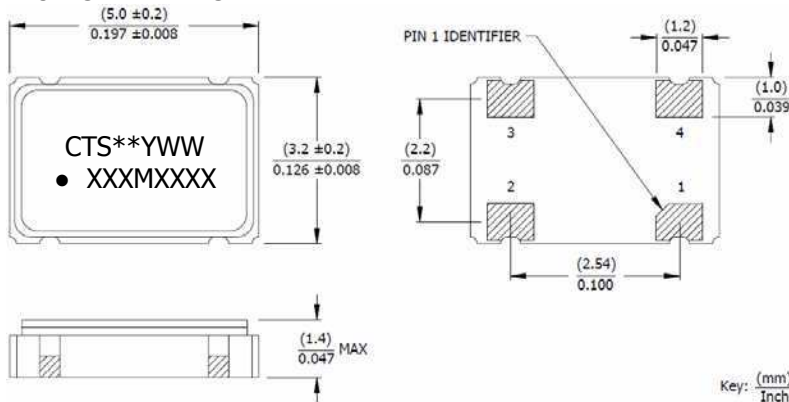

MARKING INFORMATION

- ** - Manufacturing Site Code.
- YWW - Date code, Y - year, WW - week.
- XXXMXXXX - Frequency is marked with only leading significant digits before the 'M' and 4 digits after the 'M' (including zeros).
Ex. XXMXXXX (62M5000)
XXXMXXXX (155M5200)

NOTES

- Termination pads (e4). Barrier-plating is nickel (Ni) with gold (Au) flash plate.
- Reflow conditions per JEDEC J-STD-020, 260°C maximum.
- Moisture Sensitivity Level 1 per JEDEC J-STD-020.

D.U.T. PIN ASSIGNMENTS

PIN	SYMBOL	DESCRIPTION
1	EOH	Enable
2	GND	Circuit & Package Ground
3	Output	RF Output
4	V _{CC}	Supply Voltage

SUGGESTED SOLDER PAD GEOMETRY

C_{BYPASS} should be ≥ 0.01 µF.

