

**15kV Isolation
Low Contact
Resistance
High Power
Switching
PCB or Panel
Mount
Flying Lead &
Solder Turret
Options
Excellent AC
Characteristics**

D Series 15kV, 50W

Capable of withstanding voltages up to 15kV, the D-series High Voltage Reed Relay is suitable for high reliability applications such as cardiac defibrillators, test equipment and high voltage power supplies. Two contact materials are available for low contact resistance or power switching applications.

Standard coil voltages of 5, 12 and 24 volts are available with form A and B contact configurations.

The D-series, range is now available with a new panel mounting option via nylon studs, as well as a choice of electrical connection methods (solder turret tag and flying lead) complementing the standard PCB 'through-hole' device. Choose the most appropriate device for your application using the part numbering system below.

CONTACT	UNITS	CONDITIONS	10KV FORM A		10KV FORM B		15KV FORM A				
Contact material			Rhodium	Tungsten	Rhodium	Tungsten	Tungsten				
Isolation across contacts	kV	DC or AC peak	10	10	5	5	15				
Max. switching power	W		50	50	50	50	50				
Max. switching voltage	V	DC or AC peak	1000	7000	1000	7000	10000				
Max. switching current	A	DC or AC peak	3	2	3	2	2				
Capacitance across contacts	pF	coil/screen grounded	<0.2	<0.2	<0.2	<0.2	<0.2				
Lifetime operations		dry switching	10 ⁹	10 ⁹	10 ⁹	10 ⁹	10 ⁹				
Lifetime operations		50W switching	10 ⁶	10 ⁶	10 ⁶	10 ⁶	10 ⁶				
Contact resistance	mOhms	maximum (typical)	50 (15)	250 (100)	50 (15)	250 (100)	250 (100)				
Insulation Resistance	Ohms	minimum (typical)	10 ¹⁰ (10 ¹³)	10 ¹⁰ (10 ¹³)	10 ¹⁰ (10 ¹³)	10 ¹⁰ (10 ¹³)	10 ¹⁰ (10 ¹³)				
COIL AT 20iC			5V	12V	24V	5V	12V	24V	5V	12V	24V
Must Operate	V	DC	3.7	9	20	3.7	9	20	3.7	9	20
Must Release	V	DC	0.5	1.25	4	0.5	1.25	4	0.5	1.25	4
Operate Time	ms	diode fitted	3.0	3.0	3.0	2.0	2.0	2.0	3.0	3.0	3.0
Release Time	ms	diode fitted	2.0	2.0	2.0	3.0	3.0	3.0	2.0	2.0	2.0
Resistance	Ohms		28	150	780	38	240	925	16	95	350
RELAY											
Isolation contact to coil	kV	DC or AC peak	17			17			17		
Insulation resistance contact to all other terminals	Ohms	minimum (typical)	10 ¹⁰ (10 ¹³)			10 ¹⁰ (10 ¹³)			10 ¹⁰ (10 ¹³)		
ENVIRONMENTAL											
Operating temperature range	iC	-	20 to +70			-20 to +70			-20 to +70		

CONTACT US NOW

UNITED KINGDOM

CRYDOM

T +44 (0)1202 897969

F +44 (0)1202 891918

E magnetics@crydom.com

W www.crydom.co.uk

USA

CRYDOM

T +1 858 715 7200

F +1 858 715 7280

E sales@crydom.com

W www.crydom.com

PART NUMBERING SYSTEM

Reedswitch Size - D _____

Contact Form _____

A: Form A, B: Form B

Contact Material _____

R: Rhodium T: Tungsten

Moulding Ref. No. _____

Coil Voltage _____

05: 5V, 12: 12V, 24: 24V

Mounting Style:

No suffix standard PCB mount

F: Flying lead contact terminals

T: Turret contact terminals

P: Panel mount via nylon studs, turret contact/coil terminals

Isolation Between Contacts

10: 10kV 15: 15kV (DAT only)

MECHANICAL

STANDARD

(e.g. DAT71210)

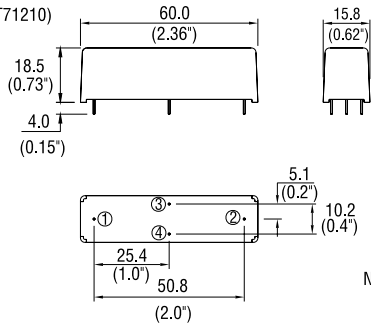

CIRCUIT DIAGRAMS (ALL VARIANTS)

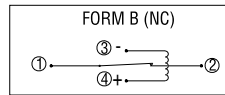
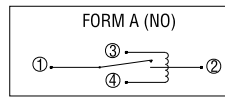

NOTE: COIL POLARITY IS IMPORTANT FOR FORM B VARIANT ONLY.

0.63mm square pin

TURRET

(e.g. DAT71210T)

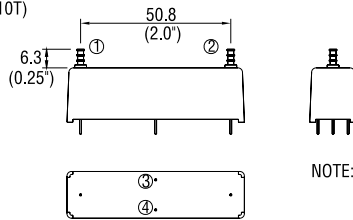

NOTE: PINS WHICH ARE NOT NUMBERED HAVE NO ELECTRICAL CONNECTION.

0.63mm square pin

PANEL MOUNT

(e.g. DAT71210P)

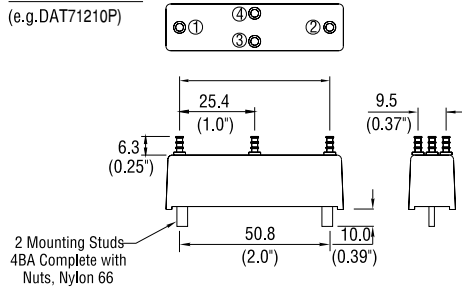

FLYING LEAD

(e.g. DAT71210F)

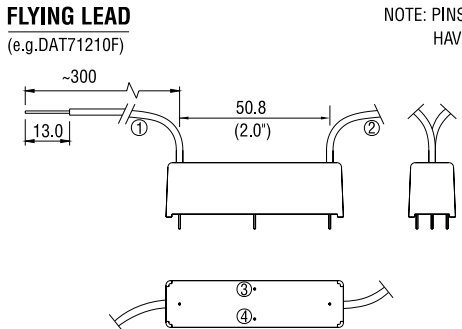

0.63mm square pin



*high voltage
reed relays*

